

**Products catalogue**

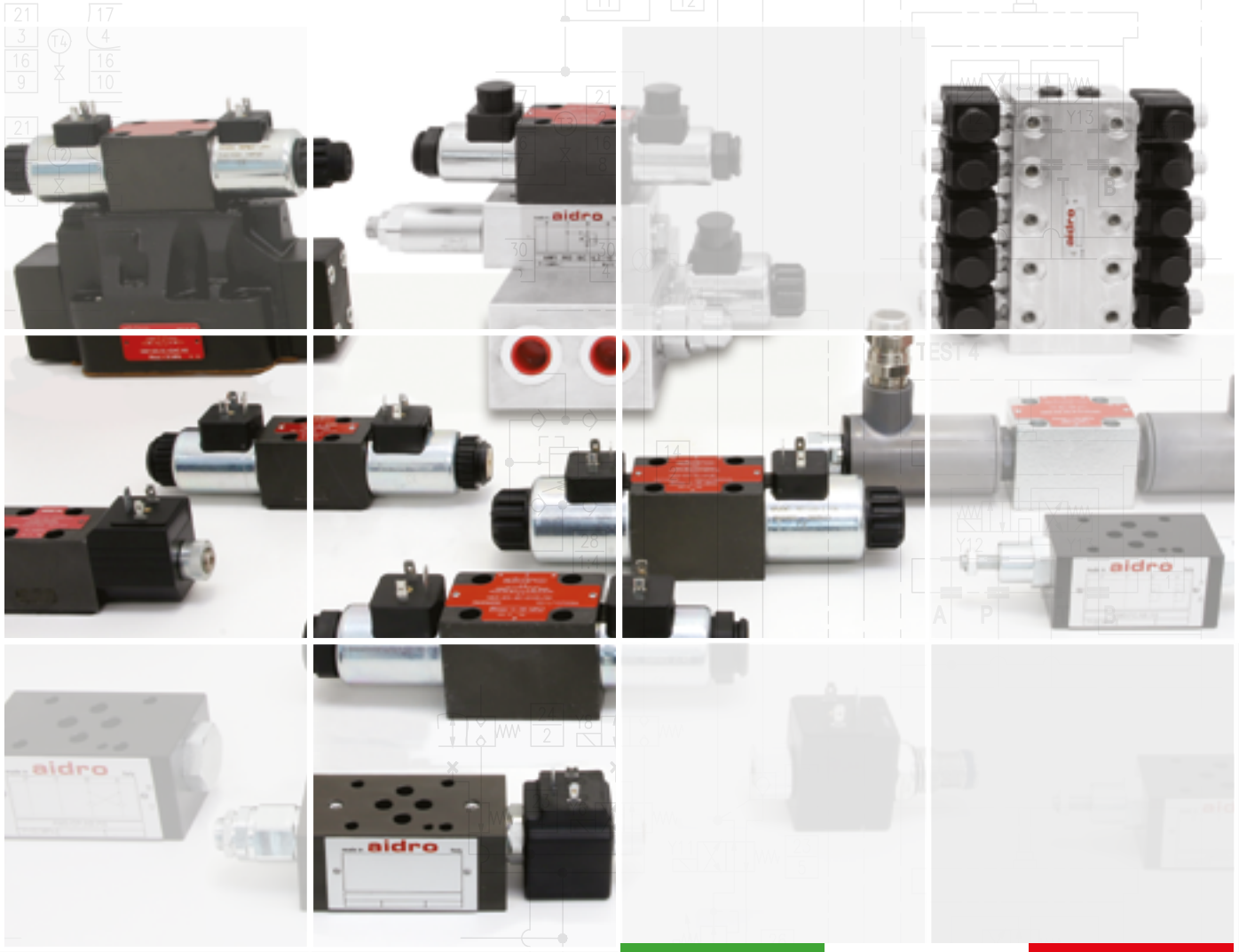

**we create for you**



- 1** **HDF stackable valves**
- 2** **CETOP 02**
- 3** **CETOP 03**
- 4** **CETOP 05**
- 5** **CETOP 07-08**
- 6** **ATEX**
- 7** **PROPORTIONAL VALVE**
- 8** **CARTRIDGE VALVES  
SAE8-SAE10**
- 9** **IN LINE  
CONTROL VALVES**
- 10** **VARIOUS SCREW IN  
CARTRIDGE AND MODULES**
- 11** **POWER PACK**
- 12** **VARIOUS**





## **1** HDF stackable valves

DIRECTIONAL CONTROL VALVES SOLENOID OPERATED - STACKABLE

**HDF-ES-\*** 0001

---

STACKABLE HAND PUMP

**AMF-HP2** 0007

---

IN LINE THROTTLE VALVE

**HFC-14** 0009

---

PILOT OPERATED CHECK VALVE

**AMF-CP-AB** 0011

---

AMF COMBINED PRESSURE RELIEF

**AMF-MOP/\*** 0013

---

AMF PRESSURE RELIEF COMBINED WITH ELECTRIC BY-PASS

**AMF-MOP/\*-EV2\*** 0017

---

AMF PRESSURE RELIEF VALVE

**AMF-MO-BA** 0019

---

AMF DIRECT OPERATED PRESSURE REDUCING VALVE

**AMF-RO-P/\*** 0021

---

AMF PROPORTIONAL PRESSURE REDUCING VALVE

**AMF-RE-P/\*** 0023

---

DIRECTIONAL CONTROL VALVES SOLENOID OPERATED - STACKABLE

**HDFH-ES** 0025

---

# 1 HDF stackable valves

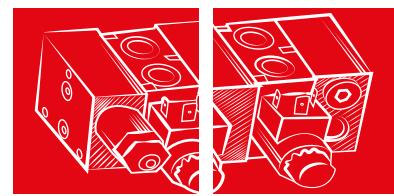

## DIRECTIONAL CONTROL VALVES SOLENOID OPERATED - STACKABLE

### HDF-ES-\*

25 l/min - 25 MPa (250 bar)

#### 1 DESCRIPTION

Distributors HDF type are the basic elements for building blocks through horizontal assembly without the need of additional manifolds. Channels A, B outputs at the upper surface of the body are provided with threads G1/4. The individual distributor bodies are connected into a compact block using three bolts. Directional valves and the other modules can be combined in order to have different hydraulic circuits. The basic surface treatment of the valve housing phosphate coated and the solenoids are zinc coated.

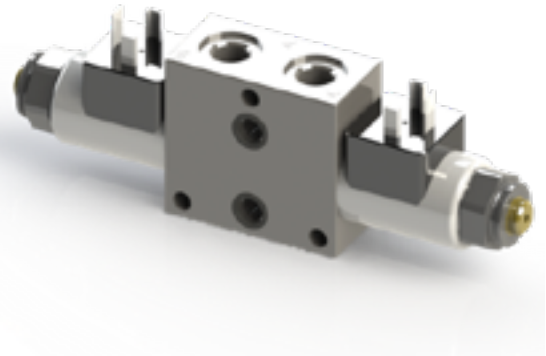

#### 2 ORDERING CODE

(1)	(2)	(3)	(4)	(5)	(6)	(7)
HDF	-	ES	-	-	-	/ 10

(1) HDF: 4-way directional control valve – Pressure 25 Mpa (250 bar)

(2) Ports variants (see 8):

- no designation: standard version
- C : P and T not passing (closing element with seals)
- B : P and T not passing (closing element without seals)
- 2 : additional ports A and B on mounting surface

(3) ES: electrically controlled, standard

(4) Spool type (see 4):

- number is the main spool type
- letter is the solenoid or spring arrangement:
  - C : 2 solenoids, spool is spring centered (3 position)
  - N : 2 solenoids, spool is detented (2 position)
  - LL : 1 solenoid (a), spool is spring offset (2 position, end to end)
  - ML : 1 solenoid (a), spool is spring offset (2 position, middle to end)
  - LM : 1 solenoid (a), spool is spring offset (2 position, end to middle)

(5) Code reserved for option and variants:

- b : only for version LL, ML, LM solenoid b installed (instead of solenoid a)
- S-\*\*: calibrated orifice on P port (see 9)
- ZT : body, solenoid tubes and coils are zinc trivalent plated

(6) Electric voltage and solenoid coils:

- 0000: no coils
- 012C: coils for V12DC
- 024C: coils for V24DC
- 220R: coils for V220/50 – V230/60 AC

(7) Design number (progressive) of the valves

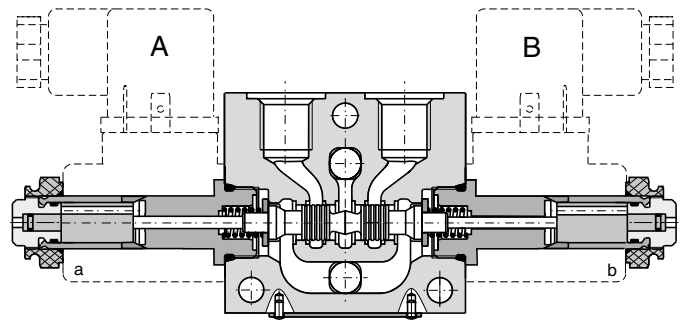
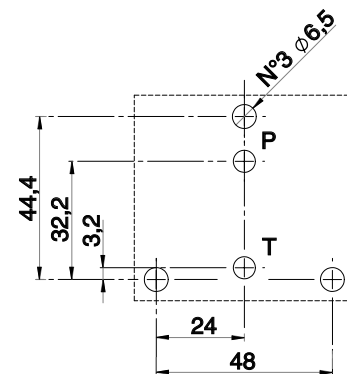

Spools, spring and solenoids combination permit to obtain almost every type of ports (P, A, B, T) connection and sequence.

For almost all types of solenoids/springs combination and for all type of spools (with the exception of spool 4), when solenoid "a" is energized, hydraulic connections are P-> B and A->T ; to obtain P->A and B->T solenoid "b" must be energized. The hydraulic connections that are obtained in the "central" (neutral) position when solenoids are not energized is the characteristic mark of the spool shape and from it derives its identification number:

- 0 = P, A, B, T connected
- 1 = P, A, B, T closed
- 3 = P closed, A, B, T connected.

For other types see 4

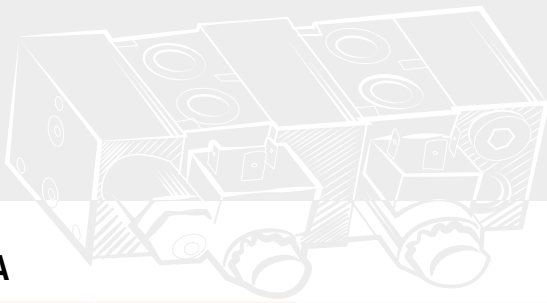

### 3 TECHNICAL DATA

Maximum nominal flow	20 l/min	<b>Electric characteristics:</b> Valves HDF-ES-* are operated by solenoid that are energized: - directly from a D.C. voltage supply: V 12 DC V 24 DC - by the use of connectors that incorporate a full wave bridge rectifier, from A.C. voltage supply: V 220/50 (V 230/60). All connectors must conform to ISO 4400 (DIN 43650) and electric circuitry must be able to carry the following rated current values: V 12 DC = 1,83 A V 24 DC = 0,92 A V 220 R = 0,08 A Permissible supply voltage variation: +5% -10%
Maximum rec. flow rate	25 l/min	
Maximum nominal pressure (P, A, B)	25 MPa (250bar)	
Maximum pressure at T port	200 MPa (200bar)	
Pressure drops	see [5]	
Protection to DIN 40050	IP 65	
Duty cycle	100%	
Service life	$\geq 10^7$ cycles	
Installation and dimensions	see [7]	
Mass	1,04 - 0,9 Kg	

### 4 SPOOL IDENTIFICATION AND INTERMEDIATE POSITION TRANSITORIES

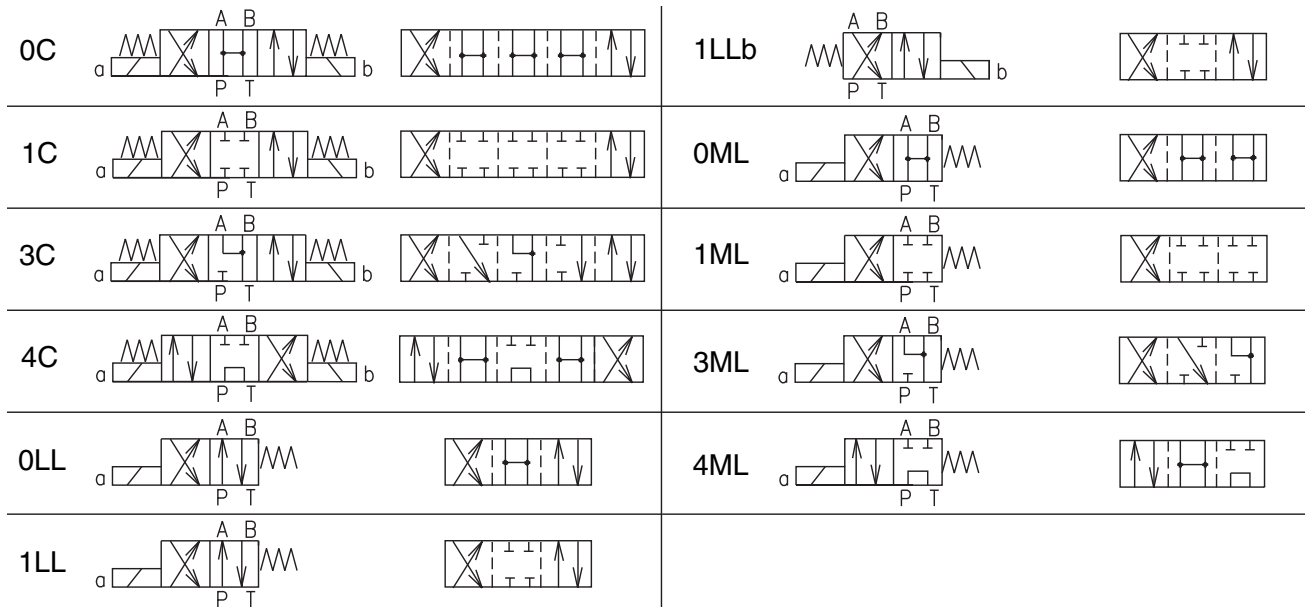

### 5 TYPICAL DIAGRAMS

Typical  $\Delta p$ -Q curves for valves HDF-ES-\* in standard configuration, with mineral oil at 36 cSt and at 50°C for flow P → A/B, A/B → T

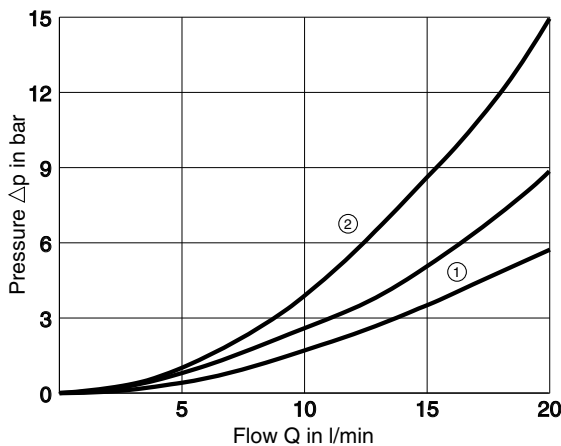

①=all spool: P → A/B and A/B → T  
 ②=spool 4 : P → A/B and P→T

### 6 POWER LIMITS

p-Q characteristic limits for safe use of HDF-ES\* solenoid operated valves. Limit curves apply to solenoid valves energized with rated voltage -5% and flushed with hydraulic fluid.

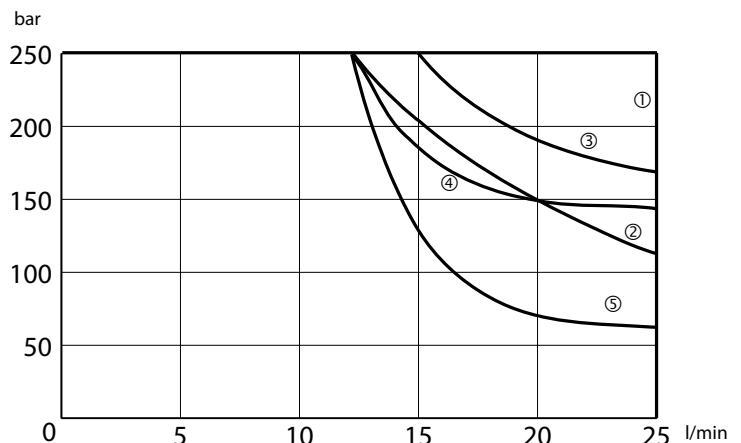

① HDF-ES-1C, HDF-ES-0ML, HDF-ES-1LL, HDF-ES-1LLb, HDF-ES-1ML  
 ② HDF-ES-4C, HDF-ES-4ML ③ HDF-ES-0C, HDF-ES-0ML  
 ④ HDF-ES-3C, HDF-ES-3ML ⑤ HDF-ES-0LL

## 7 INSTALLATION DIMENSIONS (mm)

HDF-ES-\*C-\*

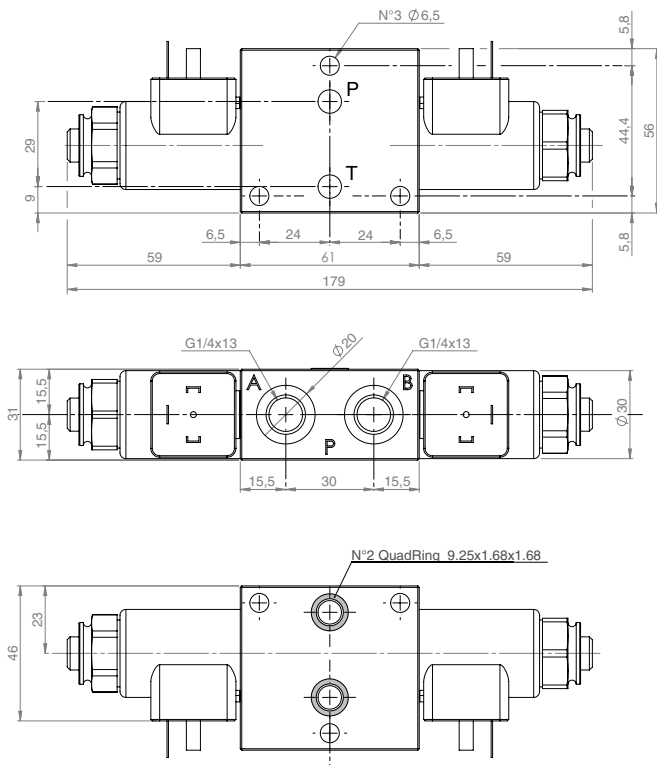

HDF-ES-\*LL-\*

HDF-ES-\*ML-\*

HDF-ES-\*LM-\*

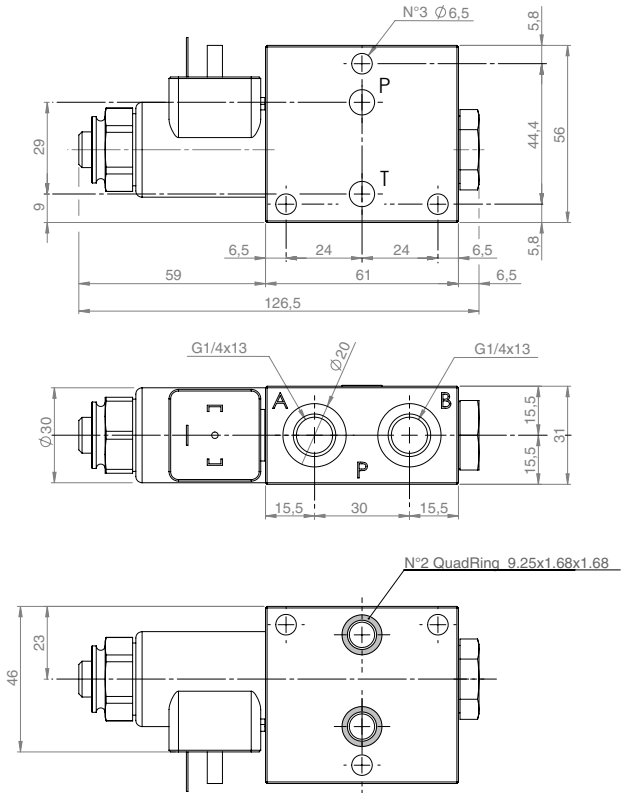

INLET PLATE, STACKABLE WITH HDF-ES VALVES, TYPE PD1-03/32-5

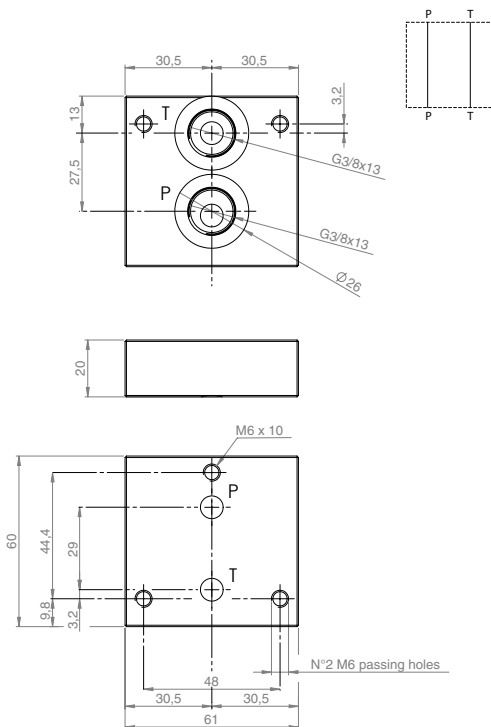

CLOSING PLATES, STACKABLE WITH HDF-ES VALVES

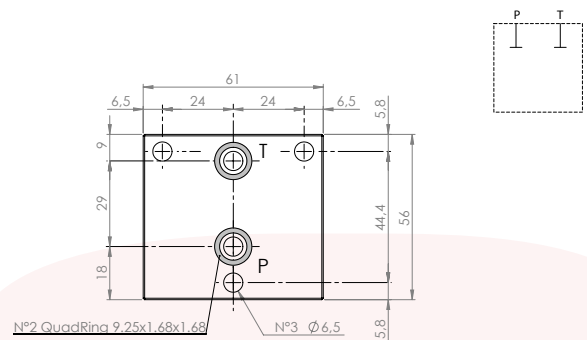



## INSTALLATION DIMENSIONS (mm)

HDFC-ES\*

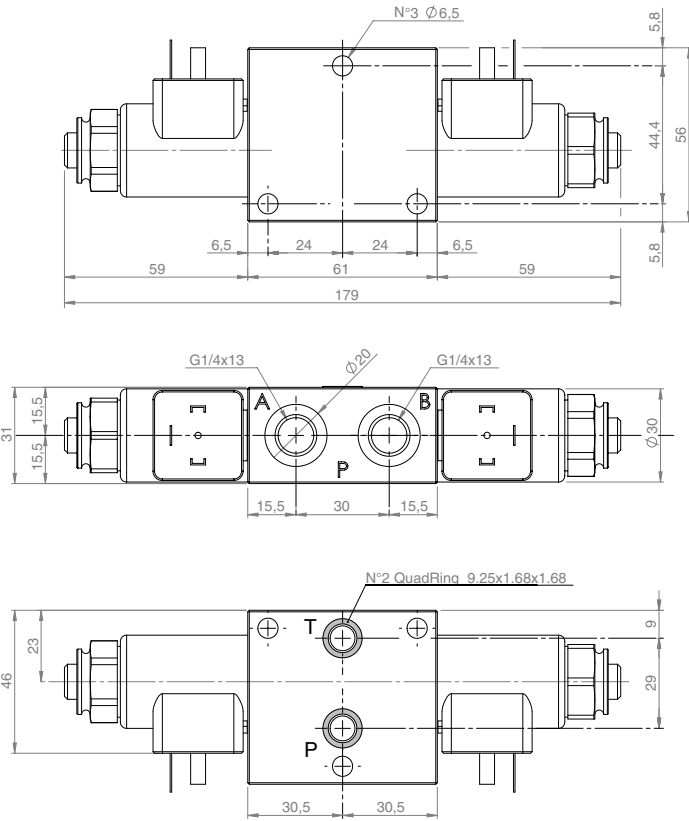

HDFB-ES\*

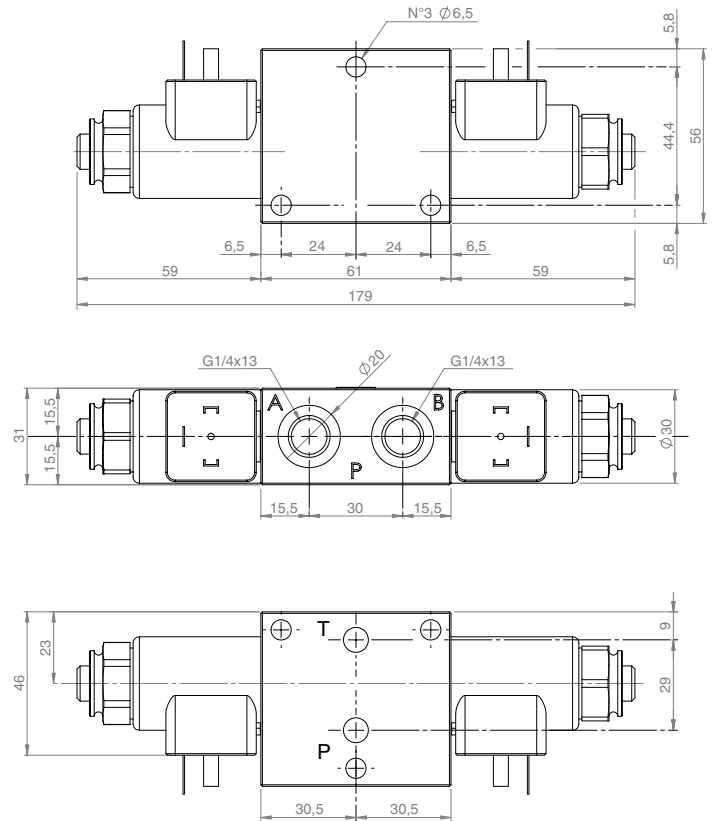

HDF2-ES\*

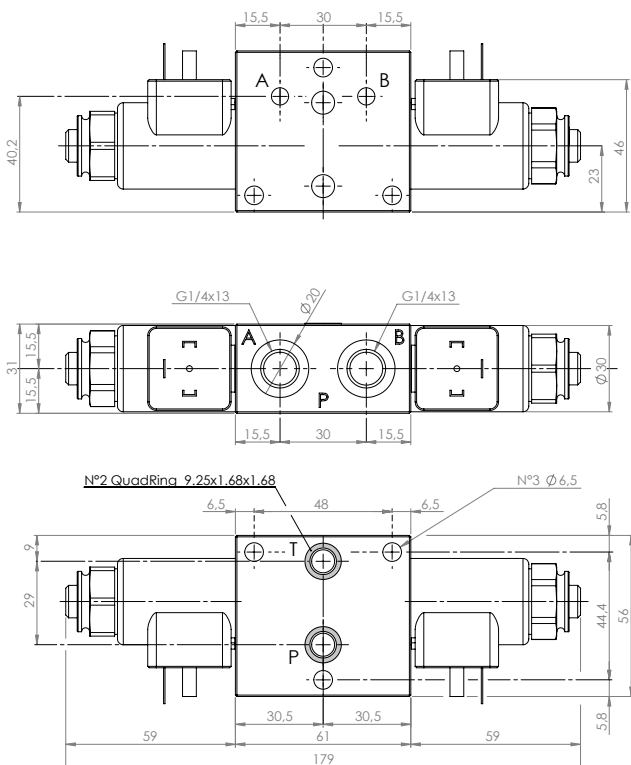

Tandem circuit plate,  
stackable with  
HDF-ES valves,  
AMF-PM-TP

inlet/outlet plate,  
stackable with  
HDF-ES valves,  
PD1-PT

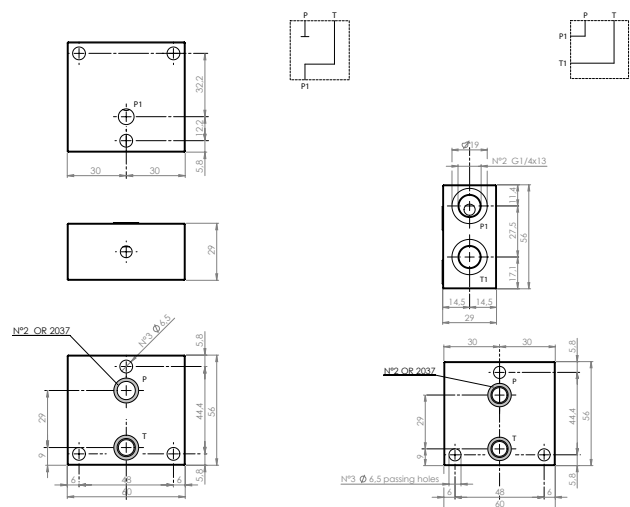

## 8 PORTS VARIANTS

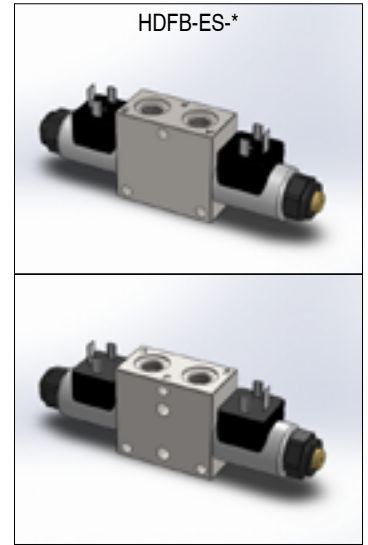
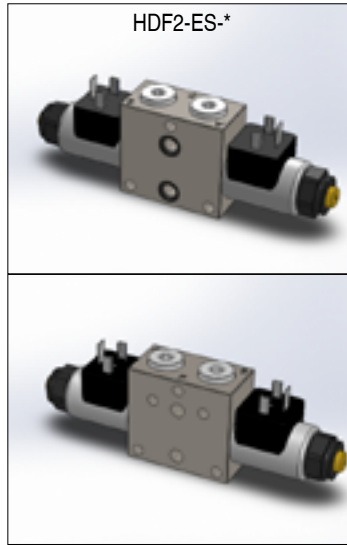
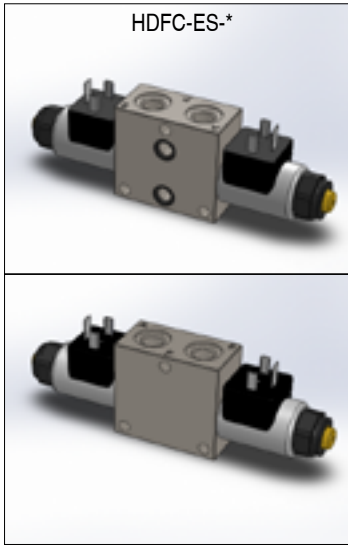

Suitable to be used as closing element in a stack of HDF-ES-\* valves

Especially designed (with A and B additional ports) to be stacked with the double pilot operated check valve type AMF-CP-AB. HDF2ES-\* valves are supplied with G1/4 A and B ports plugged

Suitable to be used as closing element in a stack of HDF-ES-\* valves

## 9 OPTIONS

Available for P and T lines "section reducer" or "stop" with O ring

Standard retaining nut can be replaced by a mechanical override nut device, code G01-E:

D (mm)	CODE
0	3S-00
1,0	3S-10
1,5	3S-15
2,0	3S-20
2,5	3S-25

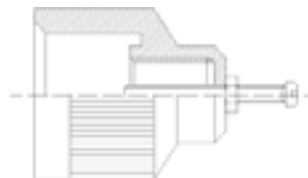
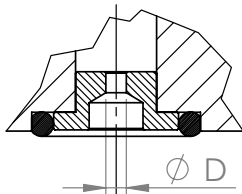

## 10 MOUNTING ANGLES KIT TYPE MAF-KIT-2

Fixing elements for HDF-ES-\* stack :

N°2 Mounting angle

N°2 M6 Screw

N°2 Washer

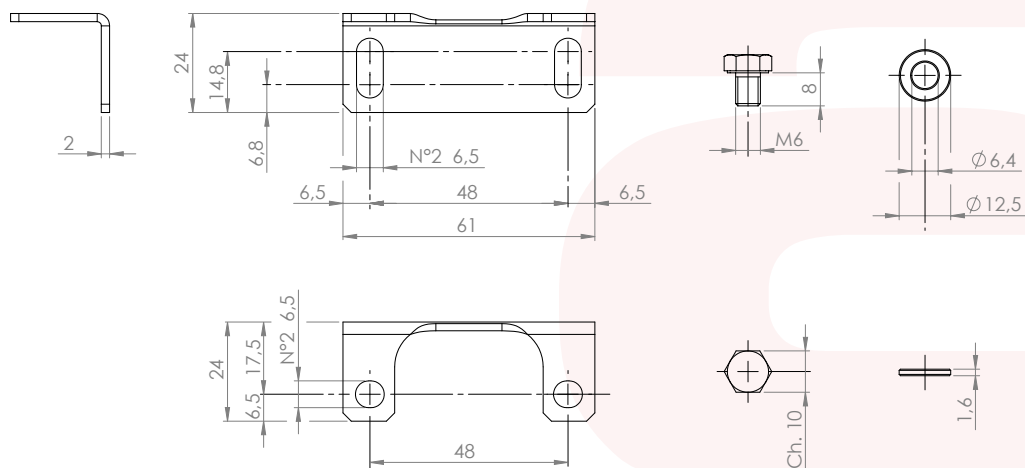

## 11 BLOCK ASSEMBLY (mm)

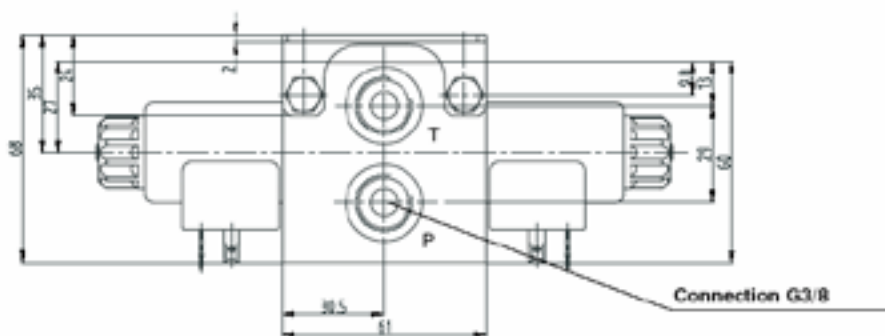
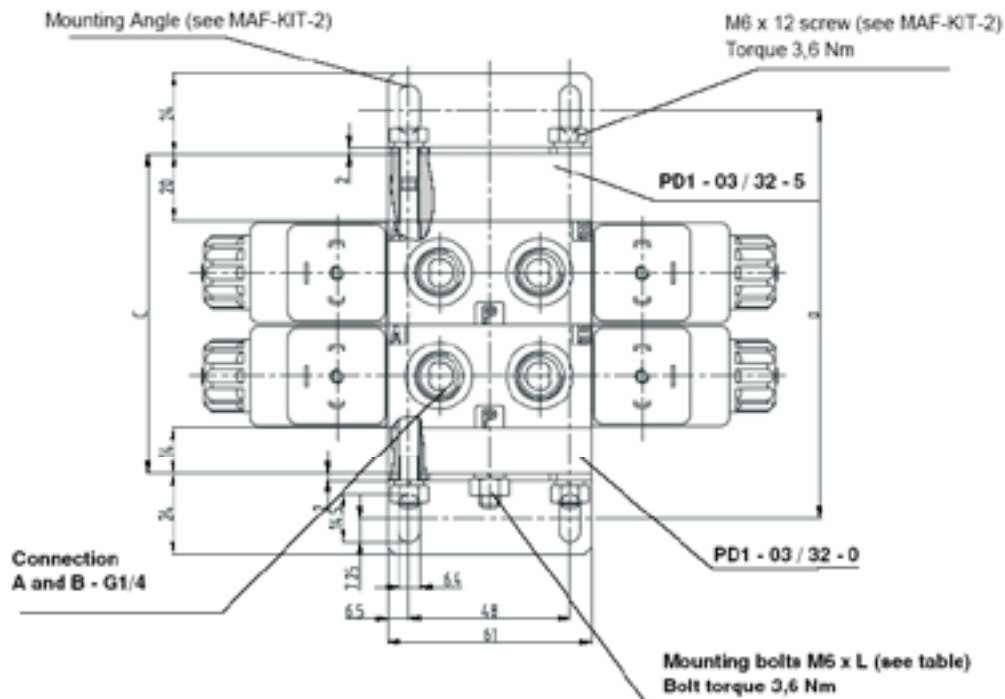
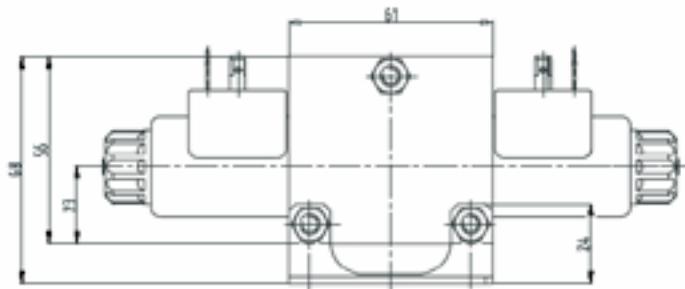

### Dimensions

Number of section	1	2	3	4	5	6	7	8
Dimension C [mm]	65	96	127	158	189	220	251	282
Dimension D [mm]	91,5	122,5	153,5	184,5	215,5	264,5	277,5	308,5
Dimension L [mm]	55	100	133	163	194	224	256	287

# 1 HDF stackable valves

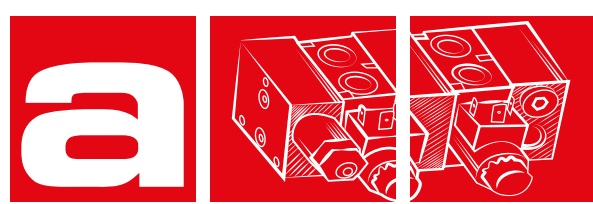

## Stackable Hand Pump

### AMF-HP2

2 cm<sup>3</sup> - 20 MPa (200 bar)

#### 1 DESCRIPTION

Stackable hand pump for HDF valves serie.

With this hand pump it is possible to operate the hydraulic systems even if there is no power supply. It is normally very useful as emergency tool. The hand lever can also be installed only in case of necessity in order to save space.

The body of the valve is in Aluminium.

#### 2 ORDERING CODE

(1)	(2)	(3)	(4)
AMF	-	HP2	/ 10

(1) AMF: module stackable with 4 way solenoid valve type HDF-ES

(2) HP2: hand pump 2 cm<sup>3</sup>

(3) Code reserved for options and variants

(4) Design number (progressive) of the pump module

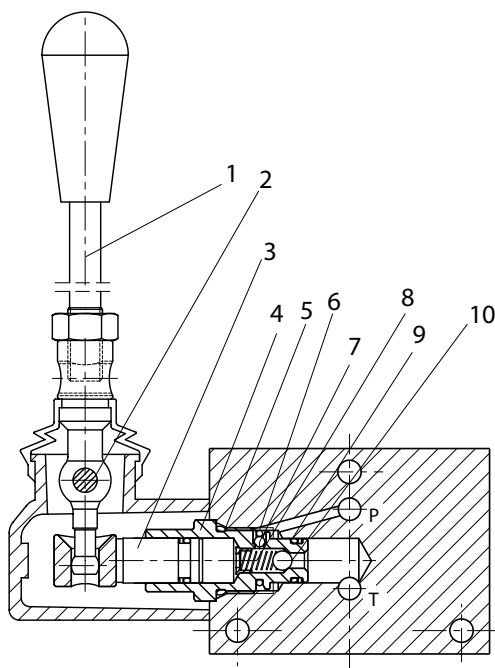
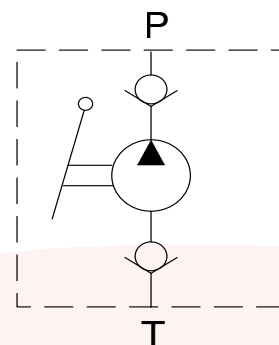
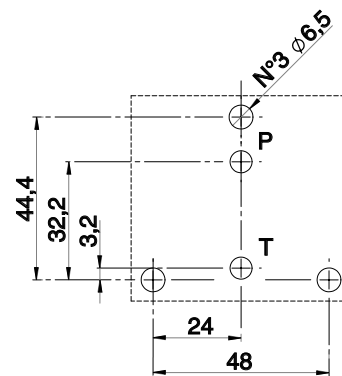

On the intake stroke piston 1 moves backward and fluid flows from port T through check valve 4, while check valve 2 is kept close. When lever moves piston 1 forward, check valve 4 is kept close by spring 3, while check valve 2 opens and permits fluid to flow in pressure line.

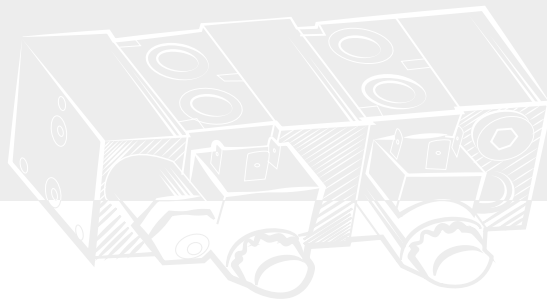

### 3 TECNICAL DATA

Displacement	2 cm <sup>3</sup> each (double) stroke
Maximum pressure	200 bar
Lever is normally used only in case of emergency and can be screwed in two different position (vertical or horizontal)	

### 4 INSTALLATION DIMENSIONS (mm)

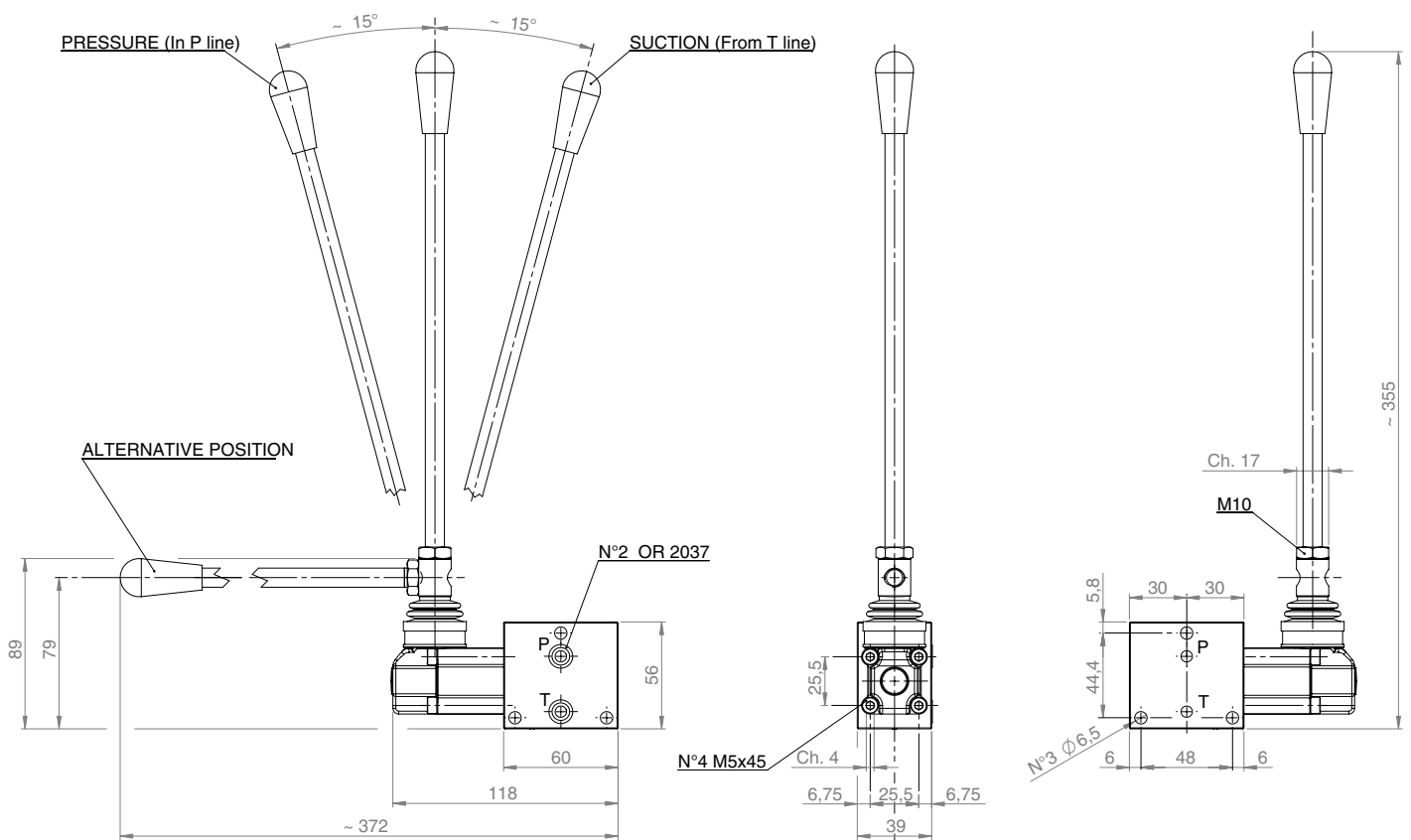

### 5 HYDRAULIC FLUIDS

Seals and materials used on standard valves AMF are fully compatible with hydraulic fluids of mineral oil base, upgraded with antifoaming and antioxidantizing agents. The hydraulic fluid must be kept clean and filtered to ISO 4406 class 21/18/15, or better, and used in a recommended viscosity range from 10 cSt to 60 cSt.

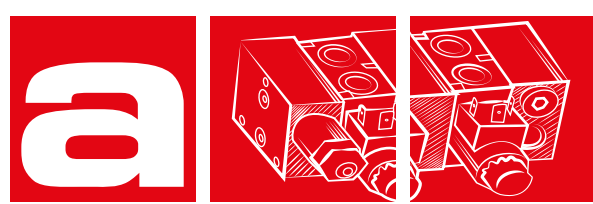

## IN LINE THROTTLE VALVE

### HFC-14

20 l/min - 35 MPa (350 bar)

#### 1 DESCRIPTION

This in line throttle valve is very useful to control the flow rate out from the ports A and B of the HDF valves.  
It can be easily installed and rotated in order to be easily accessible.



#### 2 ORDERING CODE

(1)	(2)	(3)	(4)
HFC	-	14	/ 10

- (1) HFC: Flow control for HDF valves
- (2) 14: size G1/4
- (3) Code reserved for options and variants
- (4) Design number (progressive) of the pump module

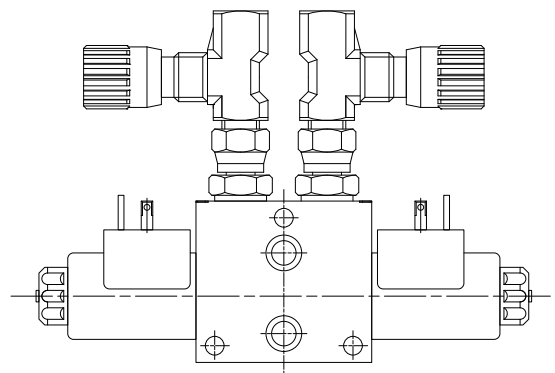
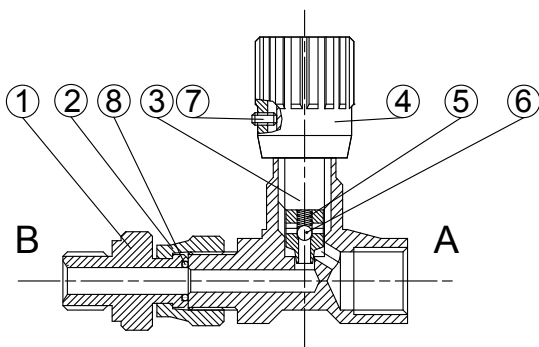

Example of HDF-ES-\* with HFC-14 installed

When fluid flows from A to B the check ball 6 (kept in its position by the spring 5) closes the main passage, thus the fluid passes through the restricted annular section, which area depends on the position of the throttling spool 3. During flow from B to A the fluid shifts the check ball 6 against the spring 5 thus permitting free flow. Typically HFC-14 valves are mounted on the A and B ports of HDF-ES-\*\*\* solenoid valves; the presence of "turning joint" 2, acting on nipple 1, allows easy installation and contemporary mounting of flow valves on both A and B ports.

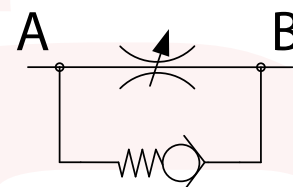

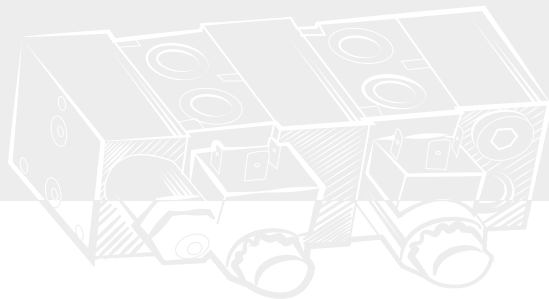

### 3 TECNICAL DATA

Maximum nominal flow	20 l/min
Maximum nominal pressure	25 MPa (250 bar)
Mass	

### 4 INSTALLATION DIMENSIONS (mm)

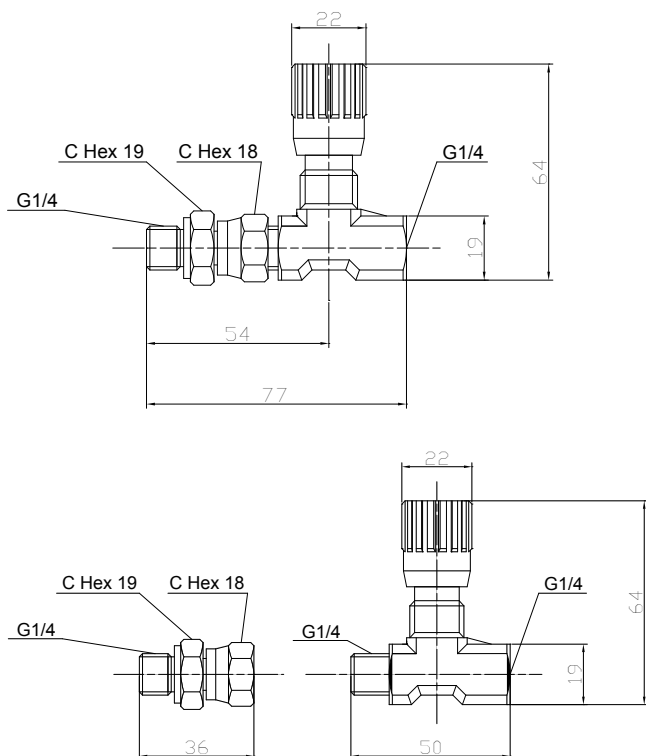

#### INSTALLATION

1. Lock the nipple 1 in a G1/4 port.
2. Put O-Ring 8 in its seat.
3. Fit the male thread of the valve in the turning connector.
4. While keeping the valve in the desired final orientation, screw the turning connector until blocking.

#### ADJUSTMENT OF THE REGULATED FLOW

To reduce the flow rate in the regulated direction (A -> B) turn clockwise knob, after having unlocked its retaining screw.

### 5 TYPICAL DIAGRAMS

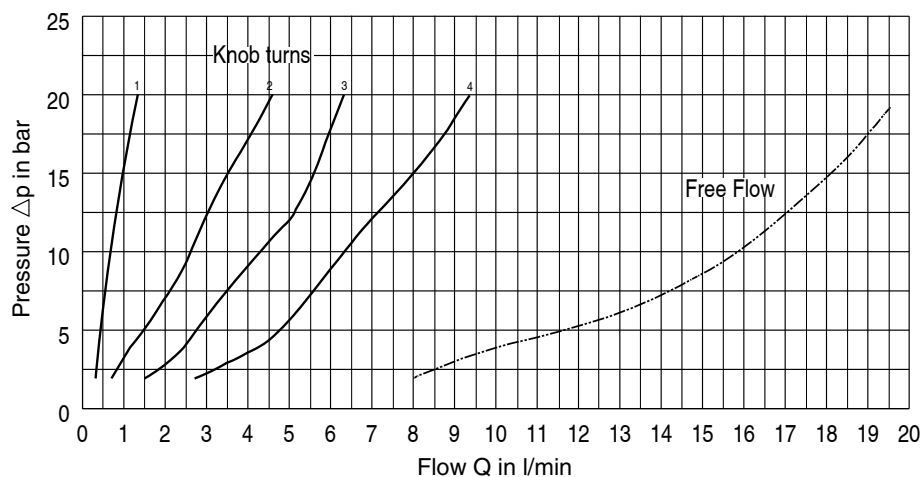

## PILOT OPERATED CHECK VALVE

### AMF-CP-AB

20 l/min - 25 MPa (250 bar)

#### 1 DESCRIPTION

Pilot operated check valve to be used with HDF2-ES directional valves which have the ports A and B plugged.  
Steel body and high precision machining of the internal parts assures a long service life and an high tightness.  
The standard coating is the phosphate coating. On demand it is possible to have the zinc coating for an higher protection degree.

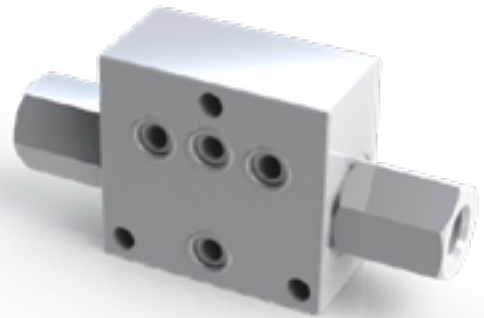

#### 2 ORDERING CODE

(1)	(2)	(3)	(4)	(5)	(6)
AMF	-	CP	-	AB	/ 10

- (1) AMF: module stackable with 4 way solenoid valve type HDF2-ES (with P and T passing)
- (2) Type end of stack module:  
no designation: standard  
C: end of stack module (P and T plugged)
- (3) CP: check valve, pilot operated (hydraulically)
- (4) AB: service lines where the controls operate
- (5) Code reserved for options and variants
- (6) Design number (progressive) of the valves

Fluid flows freely on P and T lines (AMF-CP-AB). Fluid is blocked on P and T lines (AMFC-CP-AB). On service lines A and/or B with p.o. check, fluid flows A --> A1 (and/or B --> B1) overcoming the force of spring acting on poppet and fluid is blocked A1--> A (and/or B1 --> B). When, by switching the solenoid 4-way directional valve, pressure is made available, at, for instance, port B, fluid flows B --> B1 and the pilot piston 3, shifting from its central position, forces poppet 2, on service line A, to open and permit flow A1--> A.

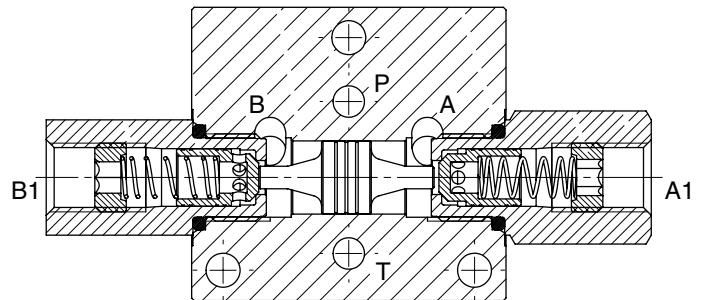
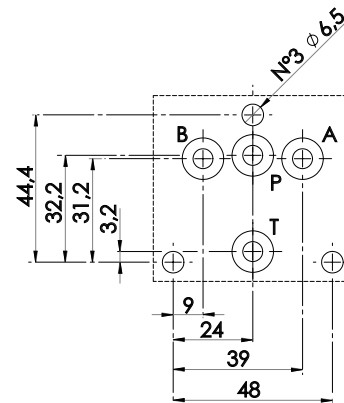

#### AMF-CP-AB

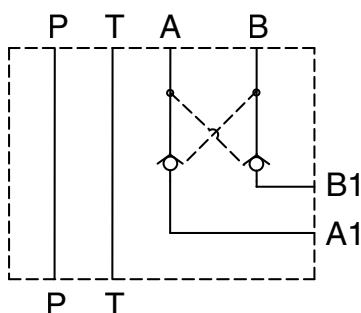

#### AMFC-CP-AB

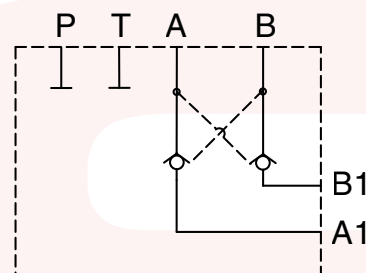



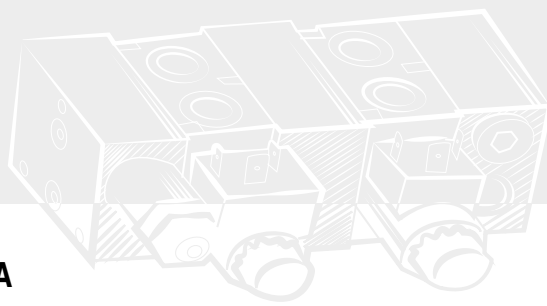

### 3 TECHNICAL DATA

Maximum nominal flow	20 l/min	Pilot area ratio piston/check valve	approx 4.7
Maximum rec. flow rate	25 l/min	Piloting pressure	To shift the pilot piston and to open the check in A the piloting pressure must be, at B:
Maximum nominal pressure	25 MPa (250 bar)		$P_p = P_b = \frac{P_{a1} + P_m \cdot P_a}{4.7}$
Material	Steel body		Were: $P_p$ = Piloting pressure
Surface protection	Phospate coating		$P_b$ = Pressure in B
Duty cycle	100%		$P_a$ = Pressure in A
Service life	10 <sup>7</sup>		$P_{a1}$ = Pressure in A1
Dimensions and Installation	see 4		$P_m$ = Check valve opening pressure (spring)
Mass	0,81kg	Cracking Pressure	1 bar

### 4 INSTALLATION DIMENSIONS (mm)

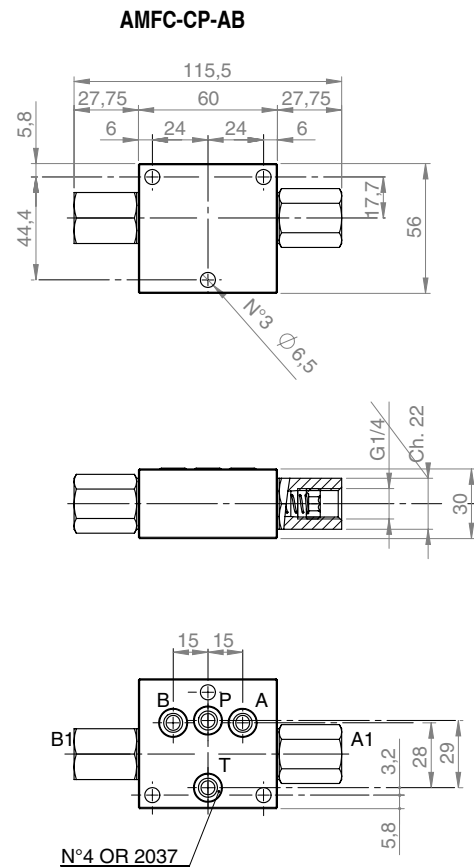
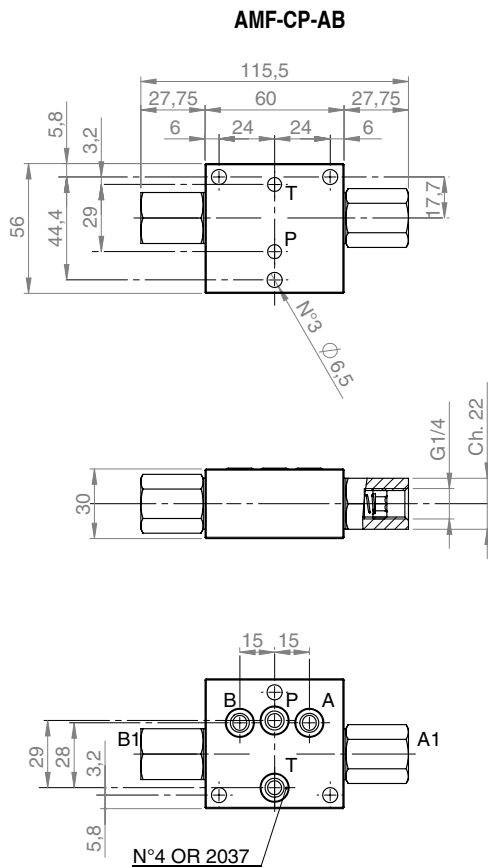

### 5 HYDRAULIC FLUIDS

Seals and materials used on standard valves AMF are fully compatible with hydraulic fluids of mineral oil base, upgraded with antifoaming and antioxidantizing agents.

The hydraulic fluid must be kept clean and filtered to ISO 4406 class 21/18/15, or better, and used in a recommended viscosity range from 10 cSt to 60 cSt.

### 6 OPTIONS

Available for P and T lines "section reducer" or "stop" with O ring

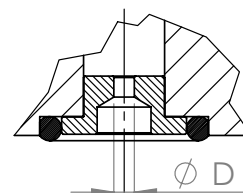

D (mm)	CODE
1,0	3S-10
1,5	3S-15
2,0	3S-20
2,5	3S-25

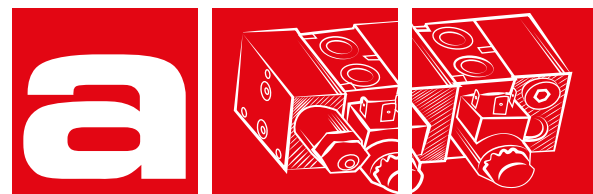

## AMF COMBINED PRESSURE RELIEF

### AMF-MOP/\*

20 l/min - 25 MPa (250 bar)

#### 1 DESCRIPTION

With this module it is possible to have the pressure relief function of the main HDF system. In combination with the pressure relief function it is possible to add other flow controls in order to bleed a specific flow to the T line.



#### 2 ORDERING CODE

(1)	(2)	(3)	(4)	(5)	(6)
AMF	- MOP	/	-	-	/ 10

(1) AMF: module stackable with HDF-ES 4 way solenoid valve

(2) MOP: pressure relief on P line

(3) Pressure adjustment ranges:  
 10 : from 32 to 100 bar  
 16 : from 63 to 160 bar  
 25 : from 100 to 250 bar

(4) Additional port or bleeding arrangement:  
 CC : no auxiliary port  
 P1 : P auxiliary port 1/4" BSPP  
 T1 : T auxiliary port 1/4" BSPP  
 CF : bleeding P->T by variable throttle  
 CV : bleeding P->T by variable throttle with graduated knob  
 QV : bleeding P->T by variable pressure compensated flow control  
 Q\* : bleeding P->T by fixed pressure compensated flow control  
 \*: 1=1 l/min  
 2=2 l/min  
 3=3 l/min  
 ...

(5) Code reserved for option and variants

(6) Design number (progressive) of the valves

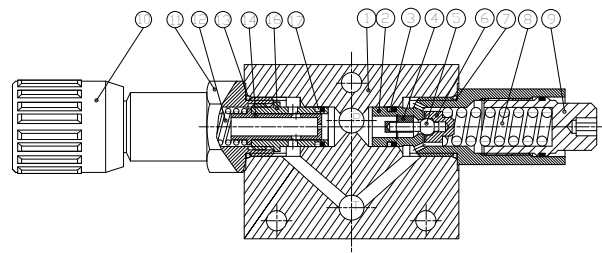
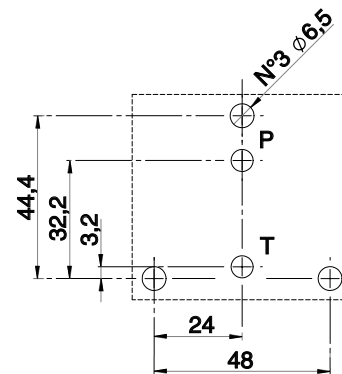

#### AMF-MOP/\*-CC

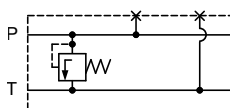

#### AMF-MOP/\*-P1

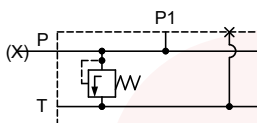

#### AMF-MOP/\*-QV

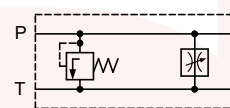

#### AMF-MOP/\*-T1

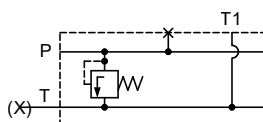

#### AMF-MOP/\*-C

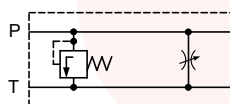

#### AMF-MOP/\*-Q(\*)

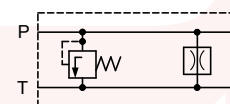

### 3 TECHNICAL DATA for AMF-MOP-CC, AMF-MOP-P1, AMF-MOP-T1

Maximum rec. flow rate	20 l/min
Maximum nominal pressure	25 MPa (250 bar)
Mass	1,20 kg

### 4 INSTALLATION DIMENSIONS (mm)

AMF-MOP-CC

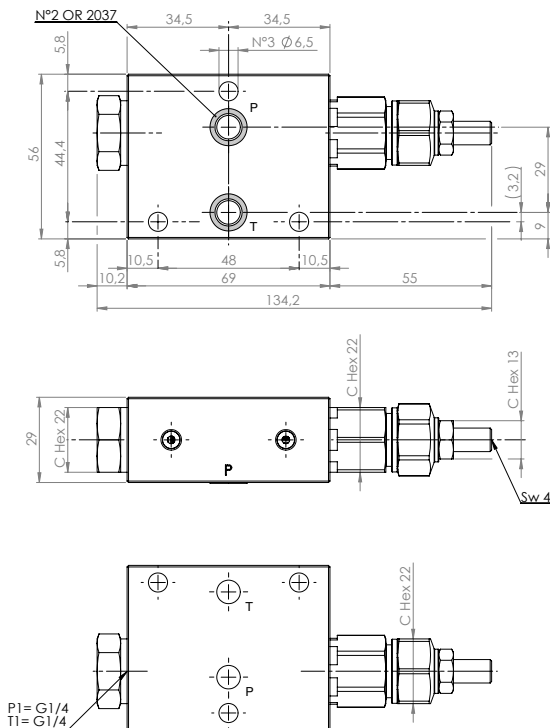

AMF-MOP-P1

AMF-MOP-T1

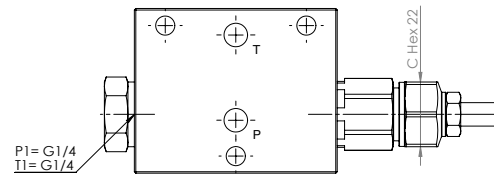

### 5 TYPICAL DIAGRAMS of PRESSURE RELIEF VALVE

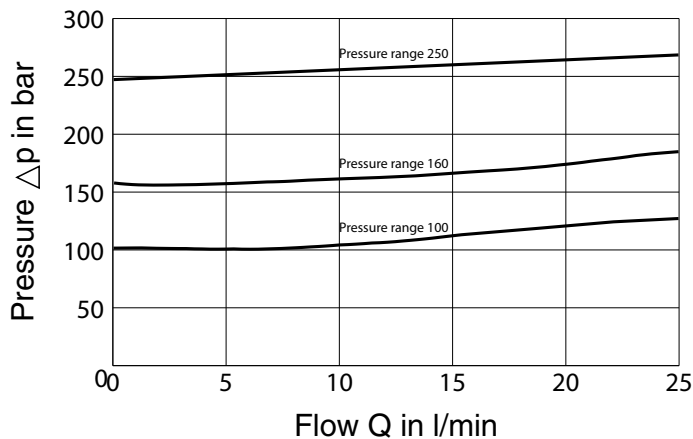

### 6 OPTIONS

Available for P and T lines "section reducer" or "stop" with O ring

D (mm)	CODE
0	3S-00
1,0	3S-10
1,5	3S-15
2,0	3S-20
2,5	3S-25

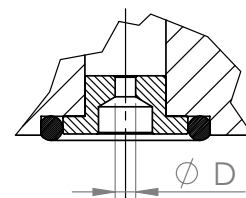

Relief pressure is reached when the axial hydraulic forces on piston 5 equal the force on spring 8; the value of the relief pressure can be therefore changed, within the range, by changing the compression of spring 8. To increase the relief pressure, turn clock wise the adjustment nut 9.

## 7 TECHNICAL DATA for AMF-MOP-CF, AMF-MOP-CV

Maximum rec. flow rate in service line	20 l/min
Maximum flow rate in bleeding line	16 l/min
Maximum nominal pressure	25 MPa (250 bar)

## 8 INSTALLATION DIMENSIONS (mm)

AMF-MOP-CF with VCF-34

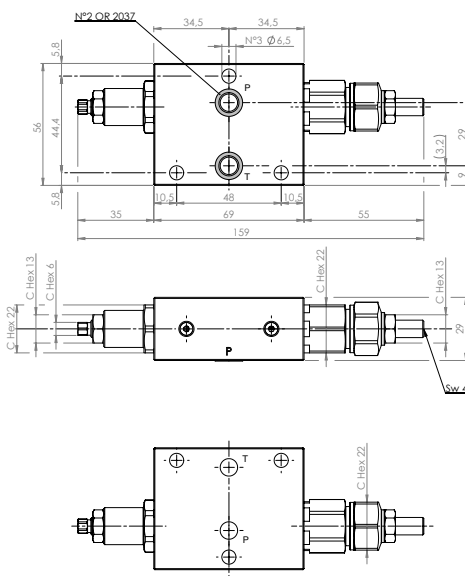

AMF-MOP-CV with FT-266/2-34

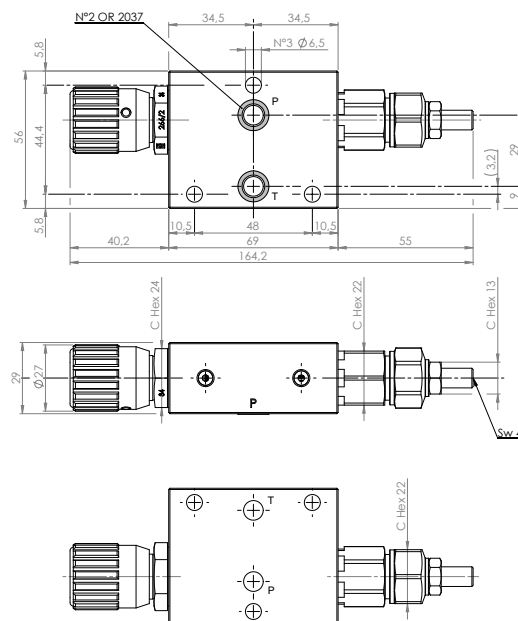

## 9 TYPICAL DIAGRAMS of FLOW CONTROL VALVE ( FT-266/2-34)

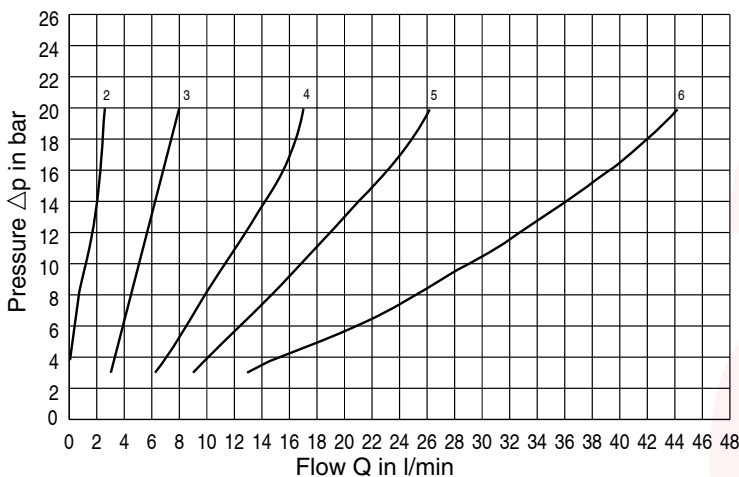

## 10 OPTIONS

Available for P and T lines "section reducer" or "stop" with O ring

D (mm)	CODE
0	3S-00
1,0	3S-10
1,5	3S-15
2,0	3S-20
2,5	3S-25

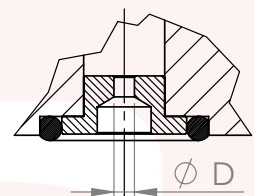

Bleeding flow, taken from main P line, is regulated by a variable throttle valve (type VCF-34 or FT266/2-34) that changes the section of an annular passage to T line. To decrease bleeding flow rate, from main P line to main T line, turn clockwise the graduated knob or the adjustment screw, after having unlocked its nut.

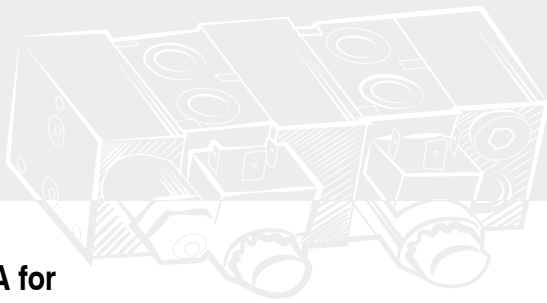

## 11 TECHNICAL DATA for AMF-MOP-Q(\*), AMF-MOP-QV

Maximum rec. flow rate in service line	20 l/min
Maximum flow rate in bleeding line	16 l/min
Maximum nominal pressure	25 MPa (250 bar)

## 12 INSTALLATION DIMENSIONS (mm)

**AMF-MOP-QV**  
with FT-268/2-34

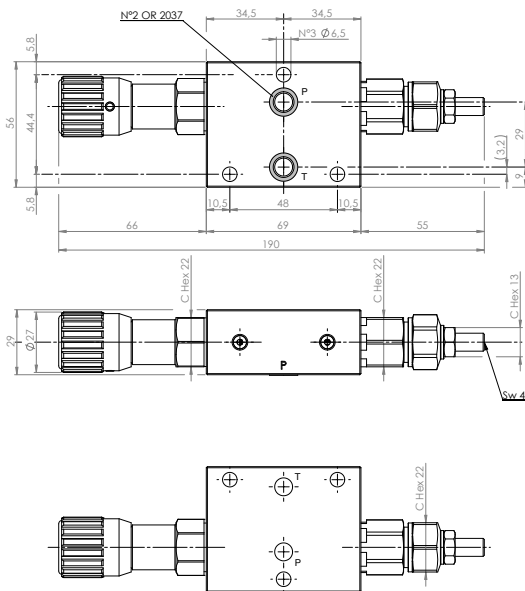

**AMF-MOP-Q(\*)**  
with VSC-34

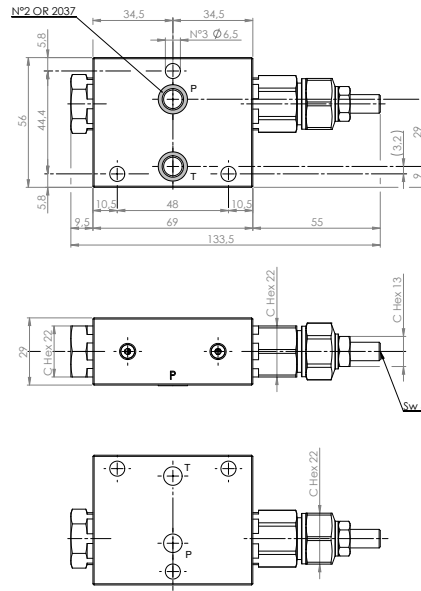

Fluid flows in P line and a part of it bleeds to T line through orifice of the throttle valve. When pressure difference between P and T increases the throttle moves reducing the area of lateral orifices, thus keeping bleeding flow rate constant at the requested value. When on line P the pressure exceeds the settled value the internal piston pushed by hydraulic axial forces, overcomes the force of spring and shifts, opening to the pressurized fluid annular passage to T, thus keeping the pressure level at the requested value

## 13 TYPICAL DIAGRAMS of VARIABLE PRESSURE COMPENSATED FLOW CONTROL VALVE (FT-268/2-34)

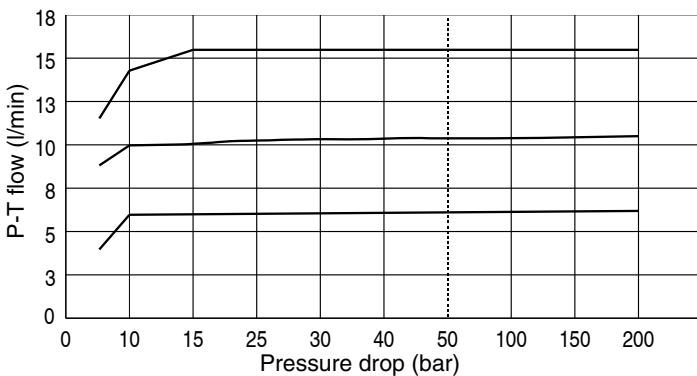

## 14 OPTIONS

Available for P and T lines "section reducer" or "stop" with O ring

D (mm)	CODE
0	3S-00
1,0	3S-10
1,5	3S-15
2,0	3S-20
2,5	3S-25

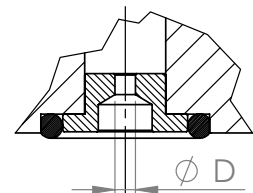

Bleeding flow, taken from main P line, is regulated by a variable pressure compensated flow control valve (FT 268/2), that changes the flow rate to T line. To decrease bleeding flow rate, from main P line to main T line, turn anticlockwise the graduated knob of valve FT-268/2-34

## AMF PRESSURE RELIEF COMBINED WITH ELECTRIC BY-PASS

### AMF-MOP/\*-EV2\*

20 l/min - 25 MPa (250 bar)

#### 1 DESCRIPTION

With this module it is possible to have the pressure relief function combined with the by-pass of the main HDF system. The by-pass valve can be normally open or normally closed. As standard the valve is a spool type valve. For specific requirements, a poppet valve with a standard SAE08 cavity can be installed in the main body.

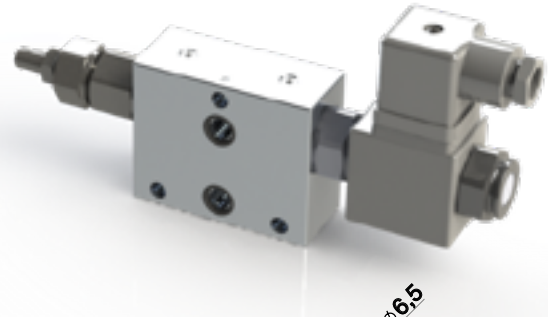

#### 2 ORDERING CODE

(1)	(2)	(3)	(4)	(5)	(6)	(7)	(8)	
AMF	-	MOP	/	-	EV2	-	/	10

(1) AMF: module stackable with 4 way solenoid valve HDF-ES

(2) MOP: pressure relief on P line

(3) Pressure adjustment ranges:  
 10 : from 32 to 100 bar  
 16 : from 63 to 160 bar  
 25 : from 100 to 250 bar

(4) EV2 : spool type 2/2 by-pass solenoid operated valve

(5) Variants:  
 O: normally open  
 C: normally close

(6) Code reserved for option and variants

(7) Electric voltage and solenoid coils:  
 0000 : no coils  
 012C : coils for V12DC  
 024C : coils for V24DC  
 220R : coils for V220-230 RAC

(8) Design number (progressive) of the valves

Fluid flows freely from P line to T line. The spool 17 is normally kept open by spring 13. When the solenoid 12 is energized, the mobile armature 11 overcomes the force of spring 13 and moves spool 17 thus closing passage between P and T. When on line P the pressure exceeds the settled value, the piston 5 is pushed by axial hydraulic forces, overcomes the force of spring 8 and shifts in its cylindrical seat and opens to the pressurized fluid annular passage to T, thus keeping the pressure level at the requested value.

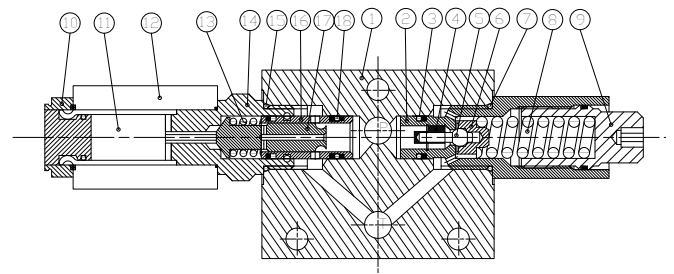
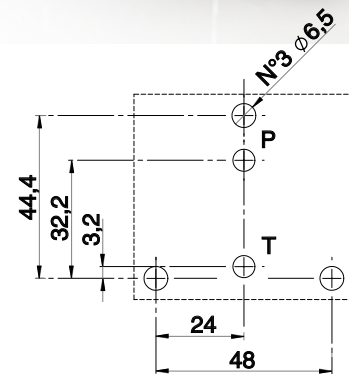

#### AMF-MOP/(\*)-EV2O

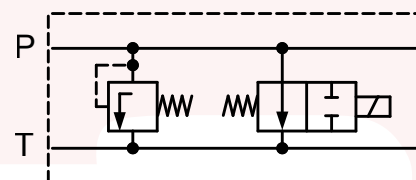

#### AMF-MOP/(\*)-EV2C

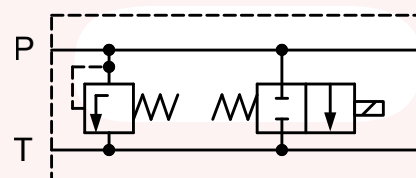

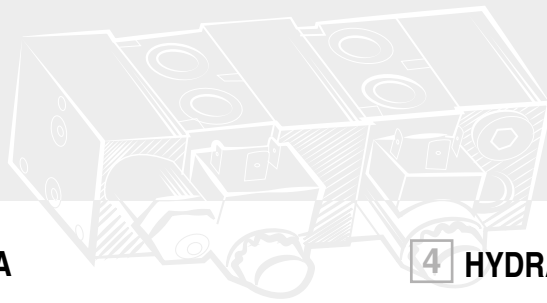

### 3 TECHNICAL DATA

Maximum rec. flow rate	20 l/min
Maximum flow rate	20 l/min
Maximum nominal pressure	25 MPa (250 bar)

### 4 HYDRAULIC FLUIDS

Seals and materials used on standard valve AMF are fully compatible with hydraulic fluids of mineral base, upgraded with antifoaming anti oxidizing agents. The hydraulic fluid must be kept clean and filtered to ISO 4406 class 21/18/15, or better, and used in a recommended viscosity range from 10 cSt to 60

### 5 INSTALLATION DIMENSIONS (mm)

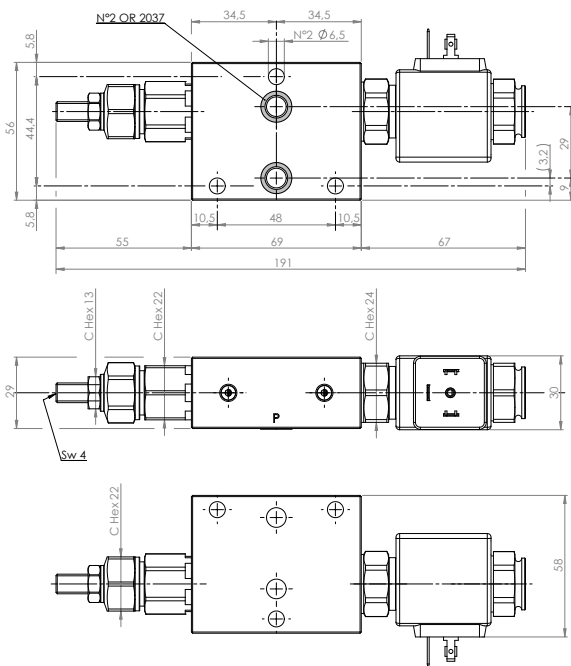

### 6 OPTIONS

Available for P and T lines "section reducer" or "stop" with O ring

D (mm)	CODE
0	3S-00
1,0	3S-10
1,5	3S-15
2,0	3S-20
2,5	3S-25

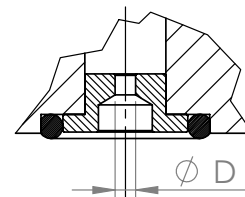

### 7 TYPICAL DIAGRAMS of PRESSURE RELIEF VALVE

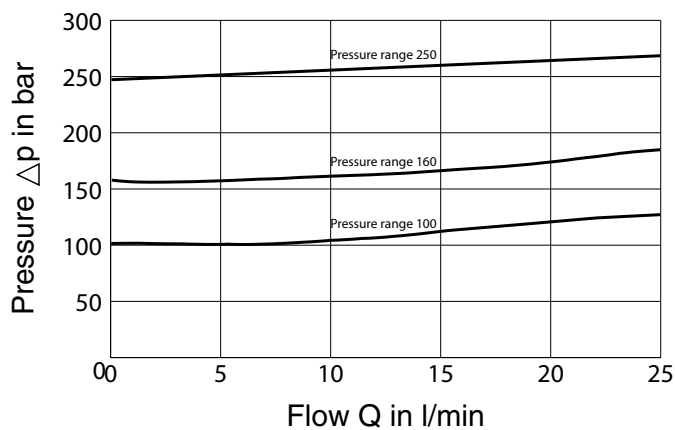

### ELECTRIC BY-PASS VALVE

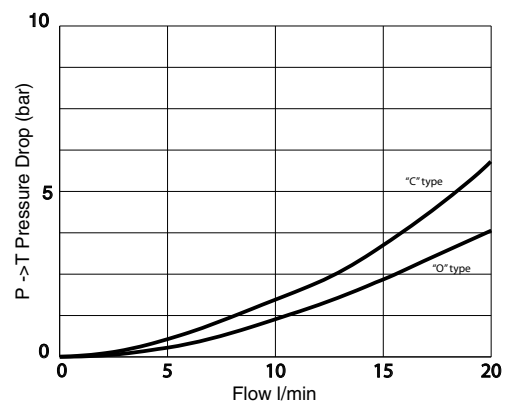

Relief pressure is reached when the axial hydraulic forces on piston 5 equal the force on spring 8; the value of the relief pressure can be therefore changed, within the range, by changing the compression of spring 8. To increase the relief pressure, turn clock wise the adjustment nut 9

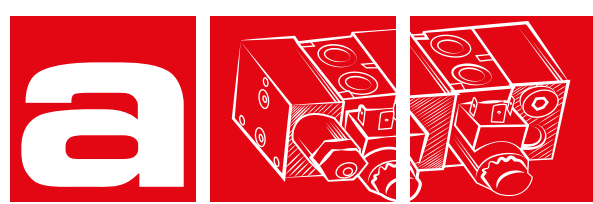

## AMF PRESSURE RELIEF VALVE

### AMF-MO-BA

20 l/min - 25 MPa (250 bar)

#### 1 DESCRIPTION

The module AMF-MO-BA is designed to control the maximum pressure in lines A and B. Two pressure relief valves direct operated can be set independently at different pressure levels.

The main body is in aluminium black anodized.

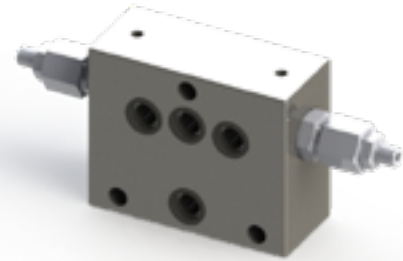

#### 2 ORDERING CODE

(1)	(2)	(3)	(4)	(5)	(6)			
AMF	-	MO	-	BA	-	-	/	10

- (1) AMF: module stackable with 4 way solenoid valve HDF2-ES
- (2) MO: pressure relief valve
- (3) BA: service lines where the control operates : A->T and B->T
- (4) Standard pressure range up to 250bar
- (5) Code reserved for option and variants
- (6) Design number (progressive) of the valves

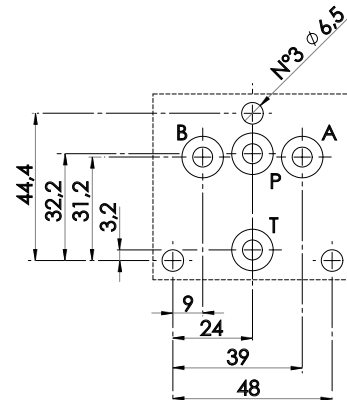

Relief pressure is reached when the axial hydraulic forces on piston 3 equal the force on spring 2 ; the value of the relief pressure can be therefore changed, within the range, by changing the compression of spring 2. To increase the relief pressure, turn clock wise the adjustment screw 9, after having unlocked its nut 8.

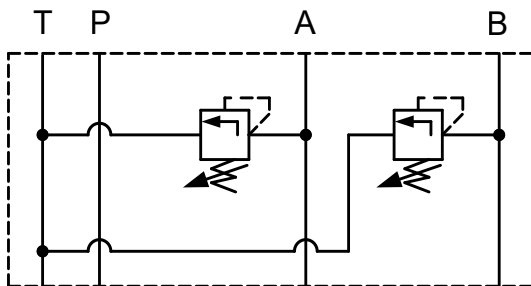
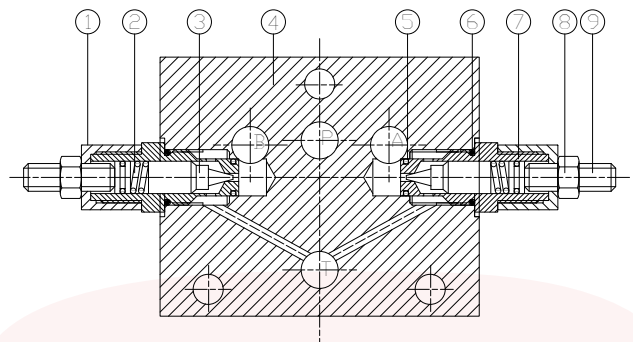



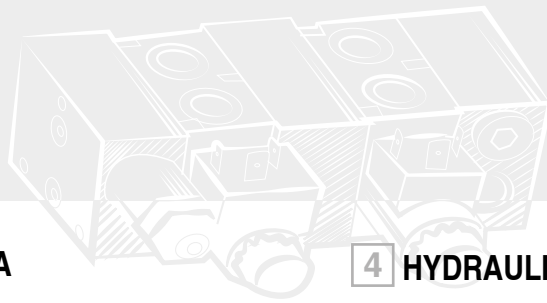

### 3 TECHNICAL DATA

Maximum rec. flow rate in P and T lines	20 l/min
Maximum flow rate in A and B lines	6 l/min
Maximum nominal pressure	25 MPa (250 bar)
Mass	1 kg

### 4 HYDRAULIC FLUIDS

Seals and materials used on standard valves AMF are fully compatible with hydraulic fluids of mineral oil base, upgraded with antifoaming and antioxidantizing agents. The hydraulic fluid must be kept clean and filtered to ISO 4406 class 21/18/15, or better, and used in a recommended viscosity range from 10 cSt to 60 cSt.

### 5 INSTALLATION DIMENSIONS (mm)

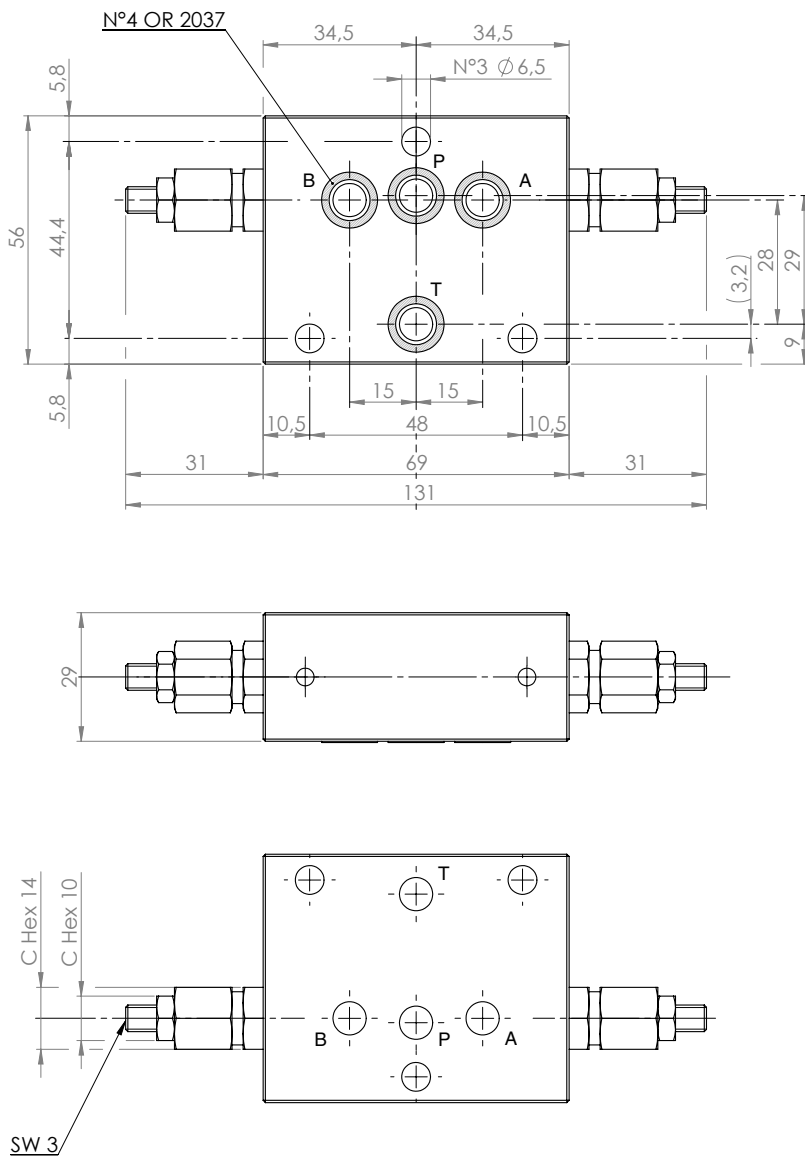

### 6 OPTIONS

Available for P and T lines "section reducer" or "stop" with O ring

D (mm)	CODE
0	3S-00
1,0	3S-10
1,5	3S-15
2,0	3S-20
2,5	3S-25

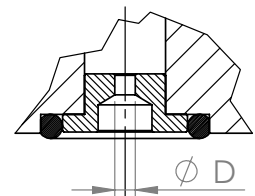

# 1 HDF stackable valves

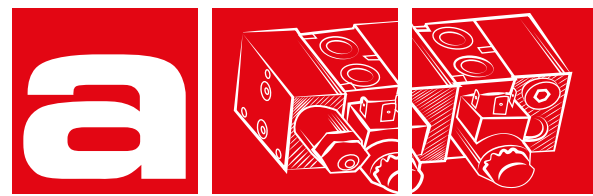

## AMF DIRECT OPERATED PRESSURE REDUCING VALVE

### AMF-RO-P/\*

20 l/min - 32 MPa (320 bar)

#### 1 DESCRIPTION

The module AMF-RO-P is designed to reduce the pressure in the P line. A 3 way cartridge valve with different pressure ranges is installed in a aluminium body suitable to be stacked with other HDF or AMF valves.

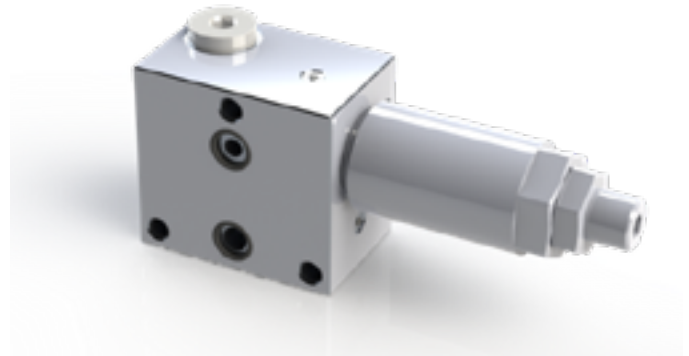

#### 2 ORDERING CODE

(1)	(2)	(3)	(4)	(5)	(6)			
AMF	-	RO	-	P	/	-	/	10

(1) AMF: module stackable with 4 way solenoid valve HDF-ES

(2) RO: direct operated pressure reducing valve

(3) P: line where the control operates

(4) PR regulated pressure range:  
 6,3: from 1,6 to 6,3 MPa (16 to 63 bar)  
 16 : from 4,0 to 16,0 MPa (40 to 160 bar)  
 20 : from 5,0 to 21,0 MPa (50 to 210 bar)

(5) Code reserved for option and variants

(6) Design number (progressive) of the valves

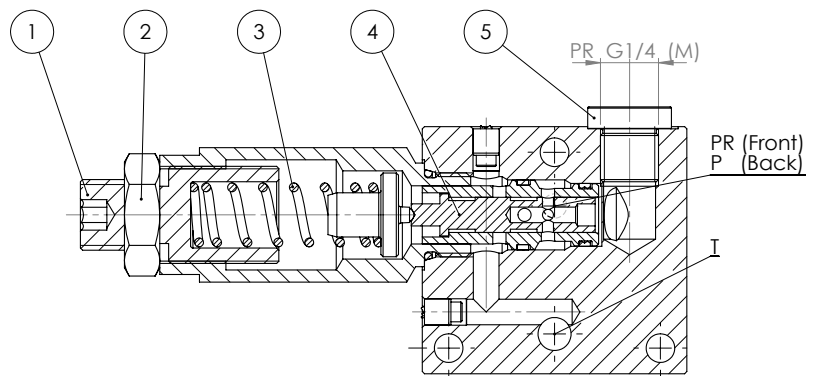
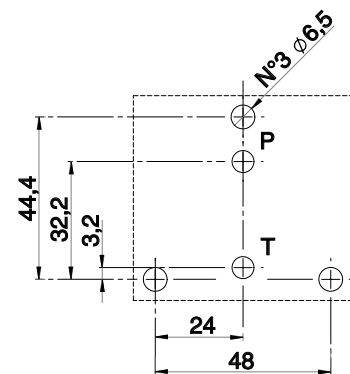

This 3-way direct operated pressure reducing valve is designed to maintain the desired value of pressure in the exit line(s) PR. Normally fluid flows from P to PR. The pressure in line PR acts on the control spool 4 (against the force due to spring 3), that shifts closing flow P to PR until the pressure falls back to the set value. If pressure in PR line overcomes the set value, the spool shifts until it opens the passage PR to T, allowing the oil to flow to the tank. Additional M (manometer) G 1/4" port is available (normally is closed by plug 5).

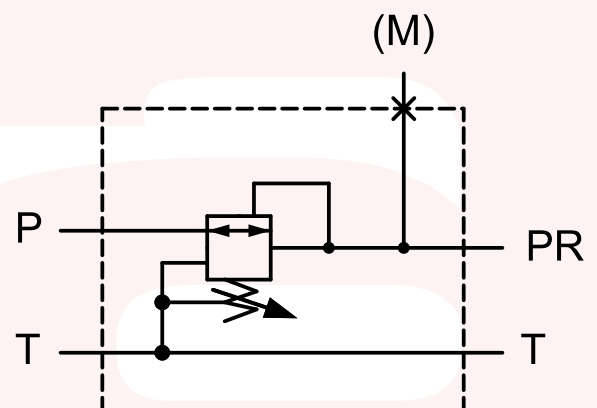

## 3 TECHNICAL DATA

Maximum nominal flow rate	20 l/min
Regulated pressure	see 2
Maximum input pressure (P line)	for 6,3 -> 16 MPa (160 bar) for 16 -> 25 MPa (250 bar) for 20 -> 32 MPa (320 bar)
Mass	0,65 Kg

## 4 HYDRAULIC FLUIDS

Seals and materials used on standard valves AMF are fully compatible with hydraulic fluids of mineral oil base, upgraded with antifoaming and antioxidantizing agents. The hydraulic fluid must be kept clean and filtered to ISO 4406 class 21/18/15, or better, and used in a recommended viscosity range from 10 cSt to 60 cSt.

## 5 INSTALLATION DIMENSIONS (mm)

Leakage between valve and mounting surface is prevented by the positive compression on their seats of 2 seals of OR type 2037 (9,25 x 1,78) or Quad-Rings (9,25 x 1,68 x 1,68 mm).

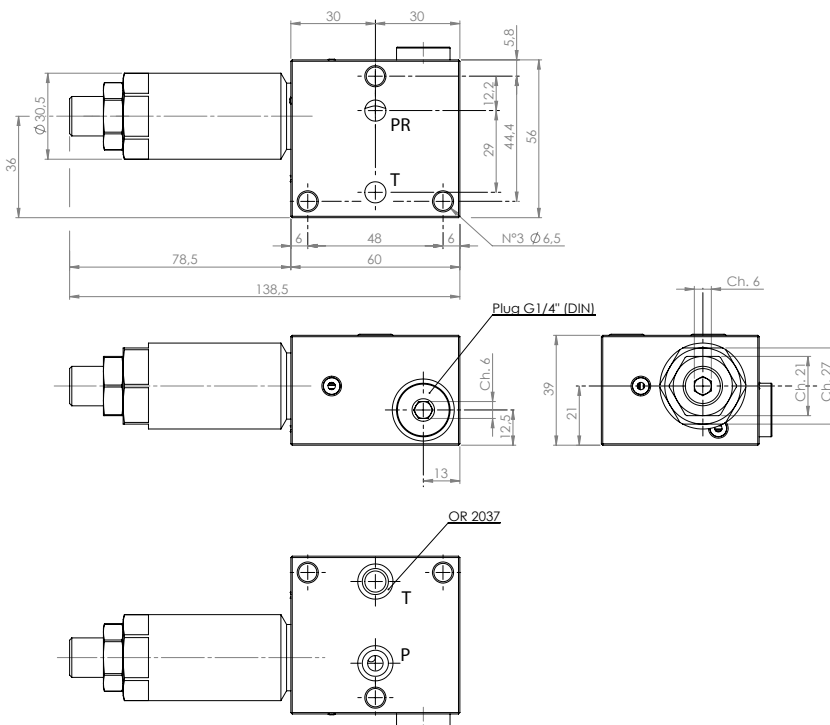

## 6 TYPICAL DIAGRAMS (measured at $v = 36$ cSt and $50^\circ\text{C}$ )

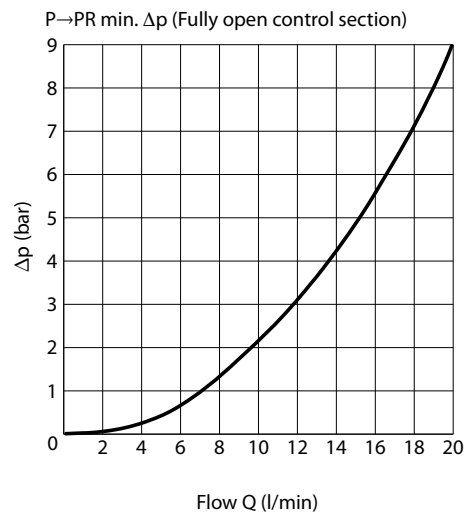
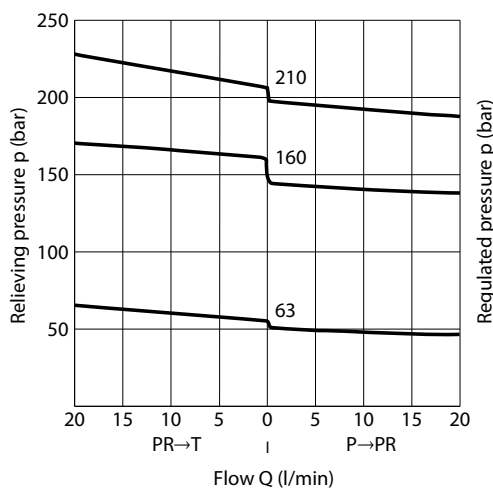

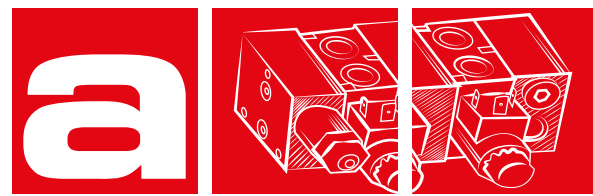

## AMF PROPORTIONAL PRESSURE REDUCING VALVE

### AMF-RE-P/\*

20 l/min 5 MPa (50 bar)

#### 1 DESCRIPTION

The module AMF-RE-P is designed to proportionally reduce the pressure in the P line. A 3 way proportional cartridge valve with different pressure ranges is installed in a body suitable to be stacked with other HDF or AMF valves.

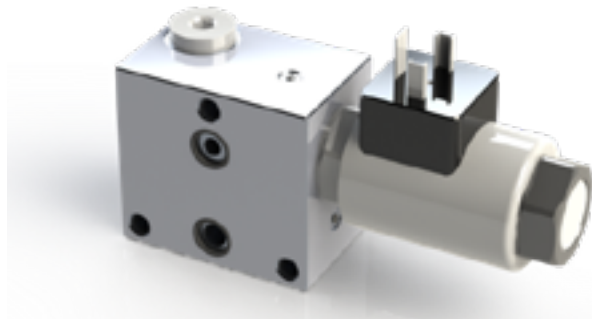

#### 2 ORDERING CODE

(1)	(2)	(3)	(4)	(5)	(6)	(7)			
AMF	-	RE	-	P	/	-	R*	/	10

(1) AMF: module stackable with 4 way solenoid valve HDF-ES

(2) RE: proportional pressure reducing valve

(3) P: line where the control operates

(4) PR regulated pressure ranges:  
 2: from 0 to 2,0 MPa ( 0 to 20bar)  
 3,2: from 0 to 3,2 MPa (0 to 32bar)

(5) R\* supply voltage:  
 \*: 2 = coil for V12DC  
 4 = coil for V24DC

(6) Connection to electric supply:  
 no designation : standard 3-PIN according to ISO 44000 (DIN 43650)  
 AMP: 2-poles AMP Junior-Timer

(7) Design number (progressive) of the valves

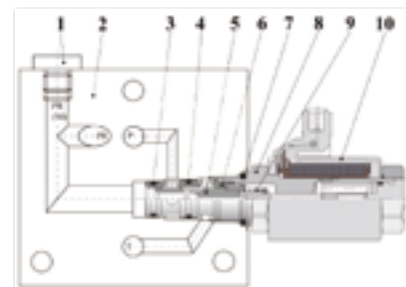
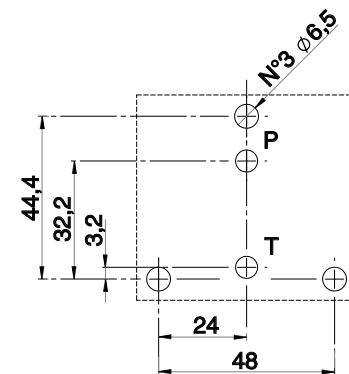

AMF-RE-P/\* is a directly operated 3-way valve controlled by proportional solenoid 10. In the de-energized state, the spring 9 keeps the spool 5 in the position that closes the P line and connects PR line to tank. When the solenoid 10 is energized, it pushes the spool with a force proportional to the current. This force makes the spool shift, thus gradually opening the passage P-PR and closing the return line. In this configuration the reduced pressure in PR and the spring force act against the solenoid force. This balance is maintained by the spool 5 that opens the passage P-PR if the reduced pressure is lower than value sets by the solenoid, or opens the passage to tank if the reduced pressure overcomes the solenoid force. Additional M (manometer) G 1/4" port is available (normally closed by plug 1)

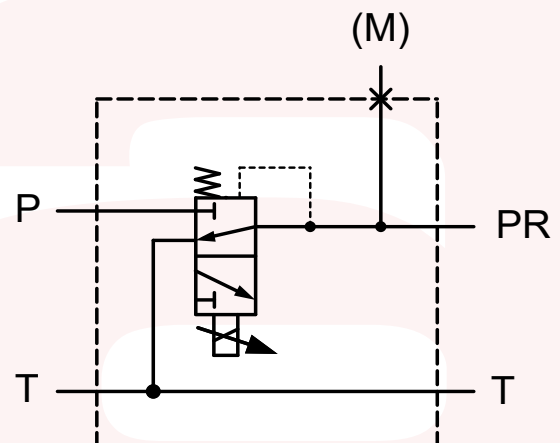



### 3 TECHNICAL DATA

Maximum nominal flow rate	20 l/min	Solenoid technical data:	
Maximum rec. flow rate	25 l/min	Control	PWM signal 100Hz
Maximum input pressure	5 MPa (50 bar)	Maximum current	12V: 1,5A    24V: 0,75A
Regulated pressure range	AMF-RE-P/2-R*: up to 2,0 MPa (20 bar) AMF-RE-P/3,2-R*: up to 3,2 MPa (32 bar)	Resistance at 20°C	12V: 7,2 Ω    24V: 21 Ω
		Duty cycle	100%
		Insulation class	F
		Enclosure type to DIN 40050	IP 65

### 4 INSTALLATION DIMENSIONS (mm)

Leakage between valve and mounting surface is prevented by the positive compression on their seats of 2 seals of OR type 2037 (9,25 x 1,78) or Quad-Rings (9,25 x 1,68 x 1,68 mm).

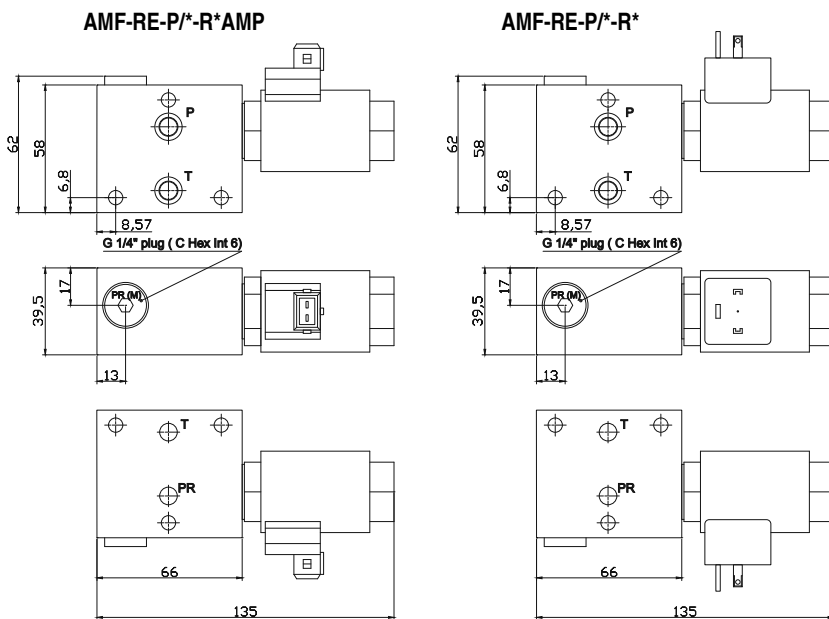

### 5 HYDRAULIC FLUIDS

Seals and materials used on standard valves AMF are fully compatible with hydraulic fluids of mineral oil base, upgraded with antifoaming and antioxidizing agents. The hydraulic fluid must be kept clean and filtered to ISO 4406 class 21/18/15, or better, and used in a recommended viscosity range from 10 cSt to 60 cSt.

### 6 TYPICAL DIAGRAMS

20 bar

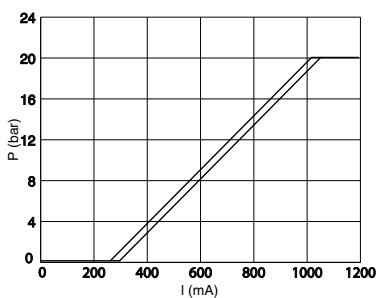

32 bar

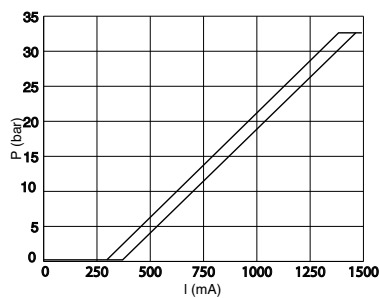

p-Q characteristics

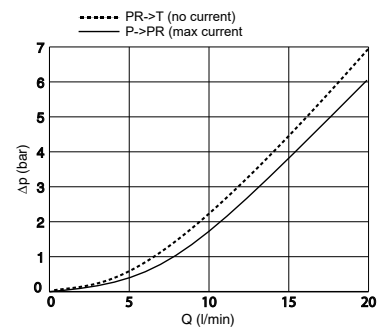

# 1 HDF stackable valves

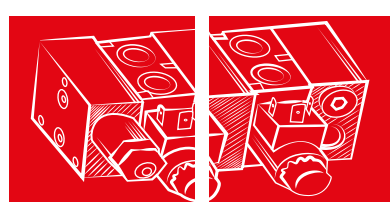

## DIRECTIONAL CONTROL VALVES SOLENOID OPERATED - STACKABLE

### HDFH-ES

50 l/min - 32 MPa (320 bar)

#### 1 DESCRIPTION

Distributors HDFH type are the basic elements for building blocks through horizontal assembly without the need of additional manifolds. Channels A, B outputs at the upper surface of the body are provided with threads G3/8. The individual distributor bodies are connected into a compact block using three bolts. Directional valves and the other modules can be combined in order to have different hydraulic circuits. The basic surface treatment of the valve housing zinc coated and the solenoids are zinc coated.

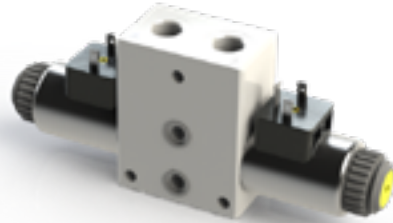

#### 2 ORDERING CODE

(1)	(2)	(3)	(4)	(5)	(6)
HDFH	-	ES	-	-	/ 10

(1) HDFH: 4-way directional control valve – Pressure 25 Mpa (250 bar)

(2) ES: electrically controlled, standard

(3) Spool type (see 4):

-number is the main spool type

-letter is the solenoid or spring arrangement:

C : 2 solenoids, spool is spring centered (3 position)

N : 2 solenoids, spool is detented (2 position)

LL : 1 solenoid (a), spool is spring offset (2 position, end to end)

ML : 1 solenoid (a), spool is spring offset (2 position, middle to end)

LM : 1 solenoid (a), spool is spring offset (2 position, end to middle)

(4) Code reserved for option and variants:

b : only for version LL, ML, LM solenoid b installed (instead of solenoid a)

S : serial connection

ZT : body, solenoid tubes and coils are zinc trivalent plated

CP : integrated pilot operated check valve

(5) Electric voltage and solenoid coils:

0000: no coils

012C: coils for V12DC

024C: coils for V24DC

115A: coils for 110/50-V 115/60 AC

230A: coils for V220/50-V230/60 AC

(6) Design number (progressive) of the valves

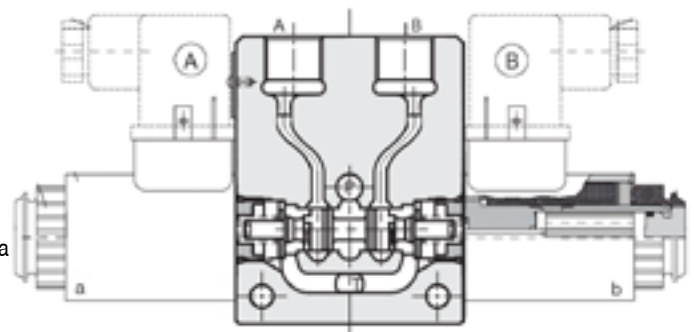
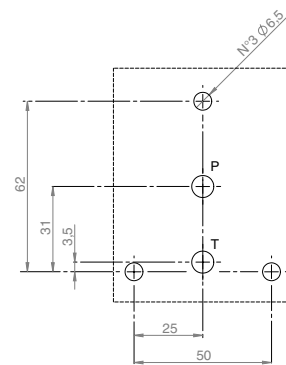

Spools, spring and solenoids combination permit to obtain almost every type of ports (P, A, B, T) connection and sequence.

For almost all types of solenoids/springs combination and for all type of spools (with the exception of spool 4), when solenoid "a" is energized, hydraulic connections are P-> B and A->T ; to obtain P->A and B->T solenoid "b" must be energized. The hydraulic connections that are obtained in the "central" (neutral) position when solenoids are not energized is the characteristic mark of the spool shape and from it derives its identification number:

0 = P, A, B, T connected

1 = P, A, B, T closed

3 = P closed, A, B, T connected.

For other types see 4

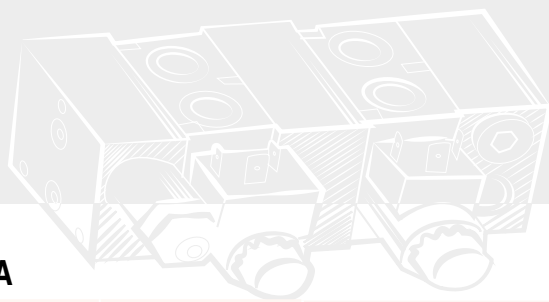

### 3 TECHNICAL DATA

Maximum nominal flow	40 l/min
Maximum rec. flow rate	50 l/min
Maximum nominal pressure (P, A, B)	32 MPa (320 bar)
Maximum pressure at T port	21 MPa (210 bar)
Pressure drops	see [5]
Protection to DIN 40050	IP 65
Duty cycle	100%
Service life	$\geq 10^7$ cycles
Installation and dimensions	see [7]
Mass	1,04 - 0,9 Kg

#### Electric characteristics:

Valve type HDFH-ES-\* are operated by solenoid that are energized :  
 Directly from a D.C. voltage supply:  
 V 12 DC = 012C V 24 DC = 024C  
 By the use of coils that incorporate a full wave bridge rectifier, from A.C. voltage supply:  
 V 110/50 - V 115/60 = 115A  
 V 220/50 - V 230/60 = 230A  
 Other available voltages are : 014C ; 048C ; 060C ; 102C ; 205C ;  
 and V24/50 = 024A  
 All connectors must conform to ISO 4400 (DIN 43650) and electric circuitry must be able to carry the following rated current values :  
 V 12 DC = 2,4 A      V 115/50 = 0,26 A  
 V 24 DC = 1,2 A      V 230/50 = 0,14 A  
 Coils with 2 electric pins, conforming with AMP connectors, are only available for DC supply (example of code : B02-012C AMP).  
 Permissible supply voltage variation :  $\pm 10\%$

### 4 SPOOL IDENTIFICATION AND INTERMEDIATE POSITION TRANSITORIES

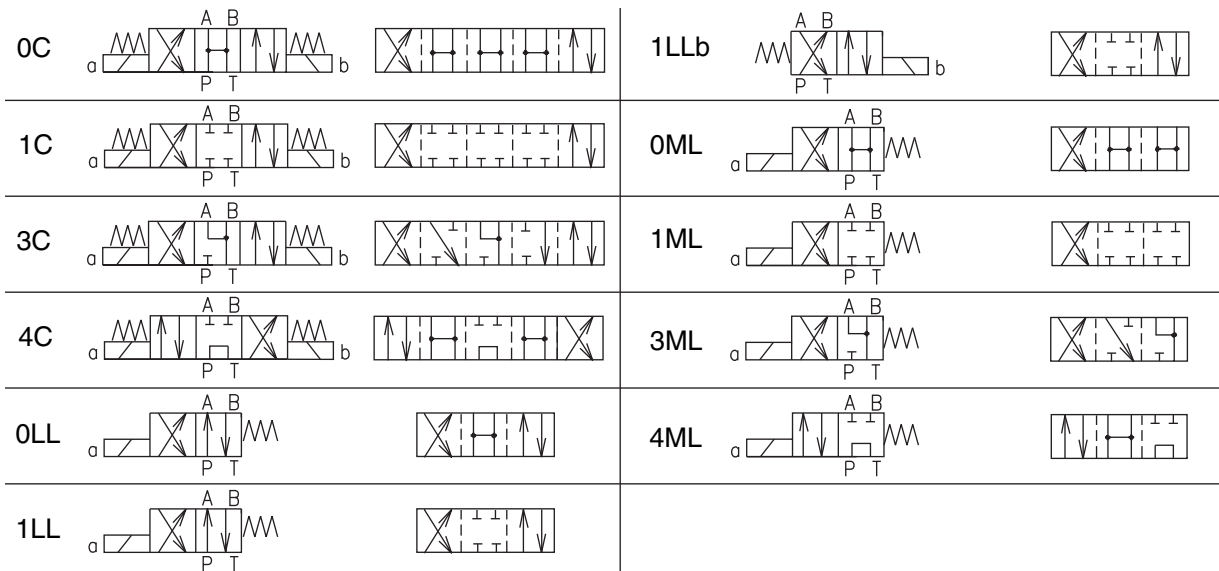

### 5 TYPICAL DIAGRAMS

Typical  $\Delta p$ -Q curves for valves HDFH -ES-\* in standard configuration, with mineral oil at 36 cSt and at 50°C for flow P -> A/B, A/B -> T

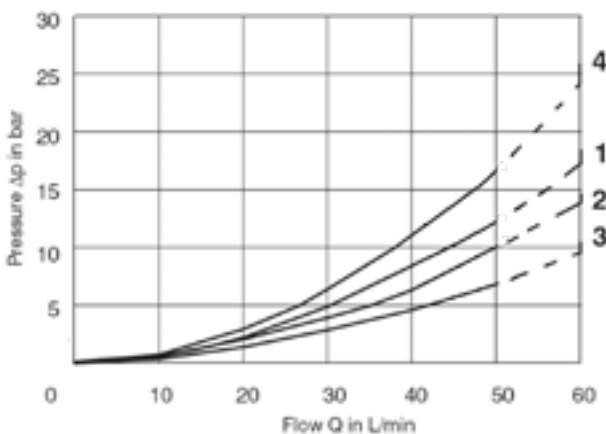

Spool	P-A	P-B	A-T	B-T	P-T
1C	2	2	2	2	
4C	4	4	1	1	1
0C	2	2	3	3	1
3C	2	2	3	3	
1LL	1	1	1	1	
1LLb	1	1	1	1	
1ML		2	2		
4ML	4		1		1
0ML	2		3		1
3ML	2		3		

## 6 POWER LIMITS

p-Q characteristic limits for safe use of HDFH -ES\* solenoid operated valves. Limit curves apply to solenoid valves energized with rated voltage -5% and flushed with hydraulic fluid.

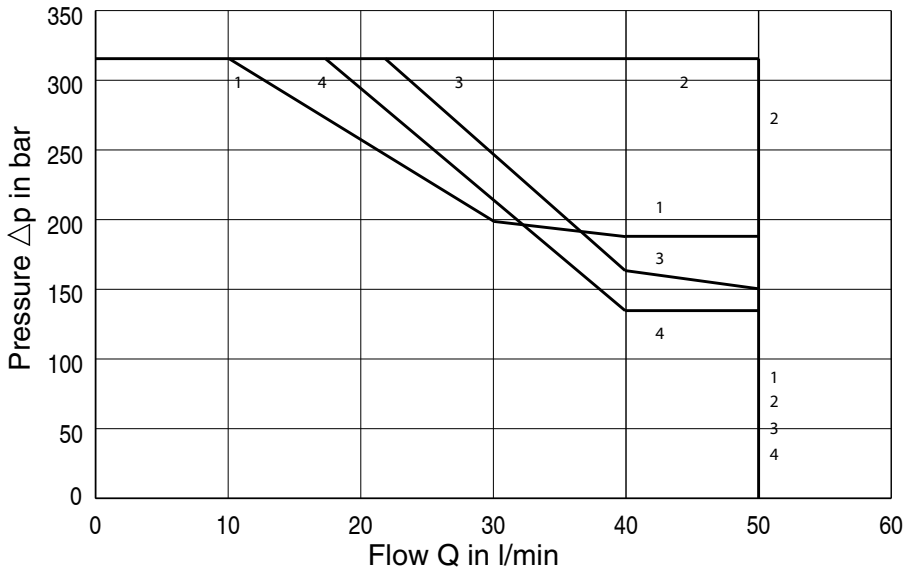

1C	2
4C	4
0C	3
3C	1
1LL	2
3ML	1
4ML	4
1ML	2
0ML	3
1MLb	2
1LLb	2
4MLb	4
0MLb	3
3MLb	1

## 7 INSTALLATION DIMENSIONS (mm)

HDFH-ES-\*

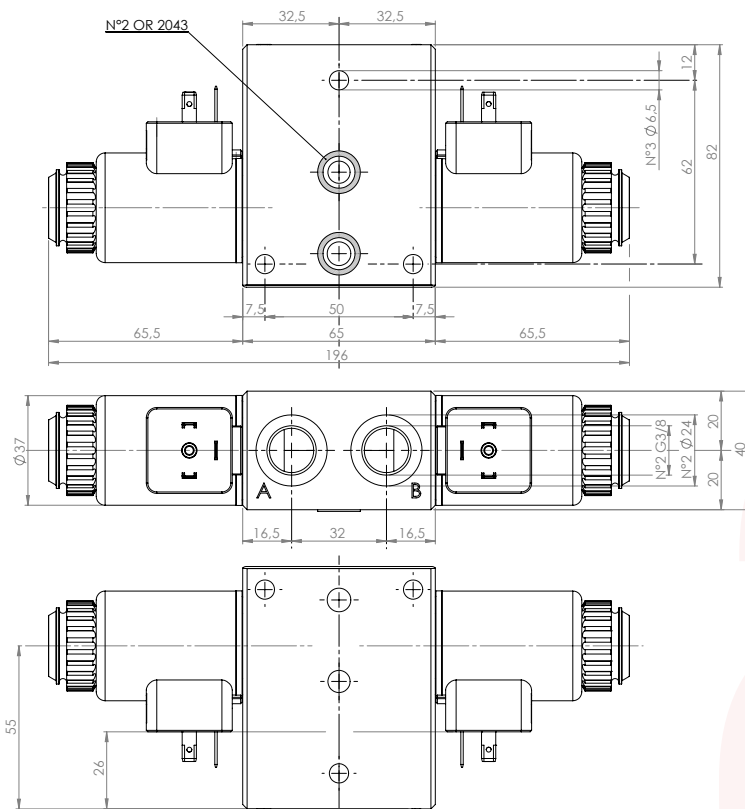

HDFH-ES-\*b

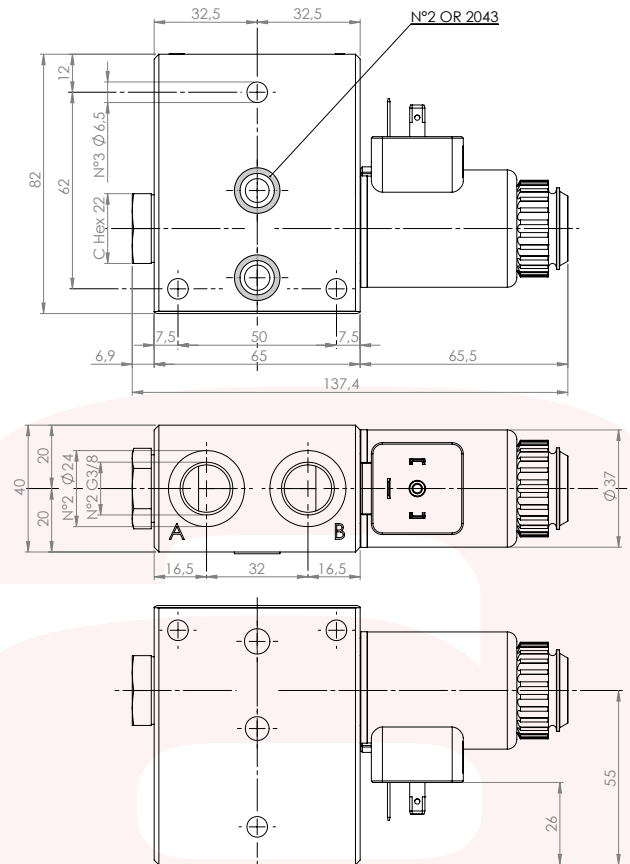



**8 INLET PLATE WITH PRESSURE RELIEF AND BYPASS STACKABLE WITH HDFH**

BD6-NT-OR

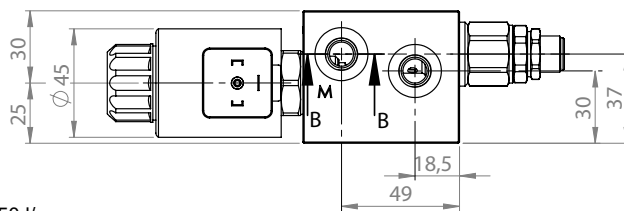
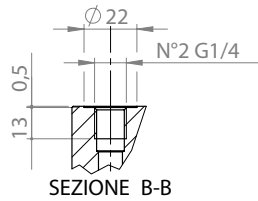
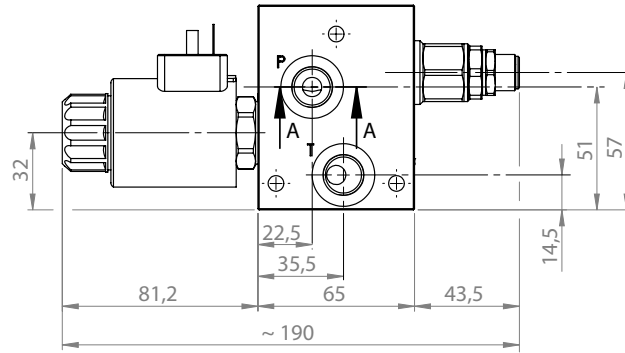
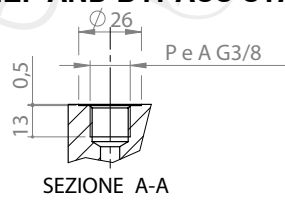

Q<sub>MAX.</sub> = 50 l/min.

P<sub>MAX.</sub> = 320 bar - 32 MPa

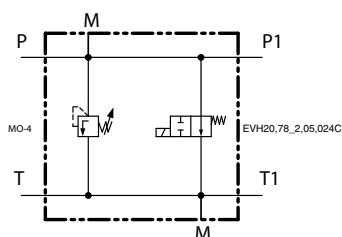
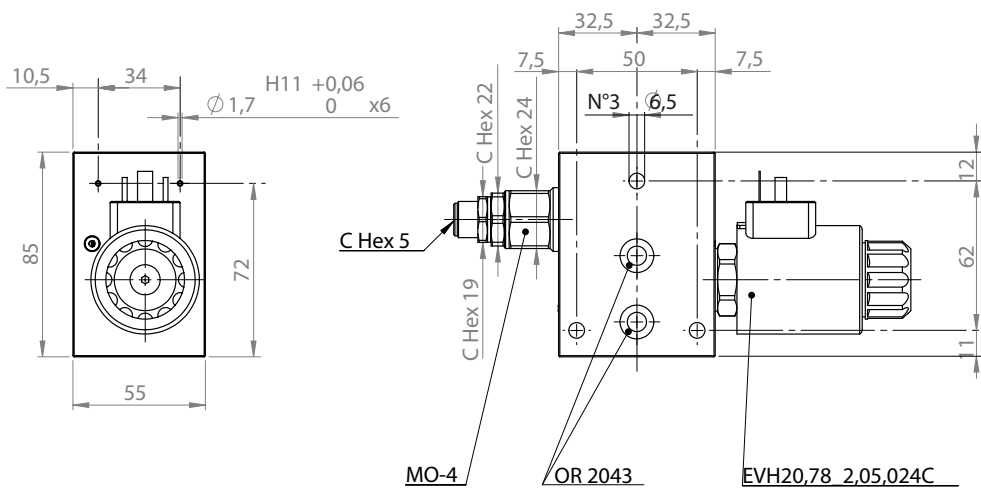

**9 INLET PLATE, STACKABLE WITH HDFH-ES**

PD2-38-AL

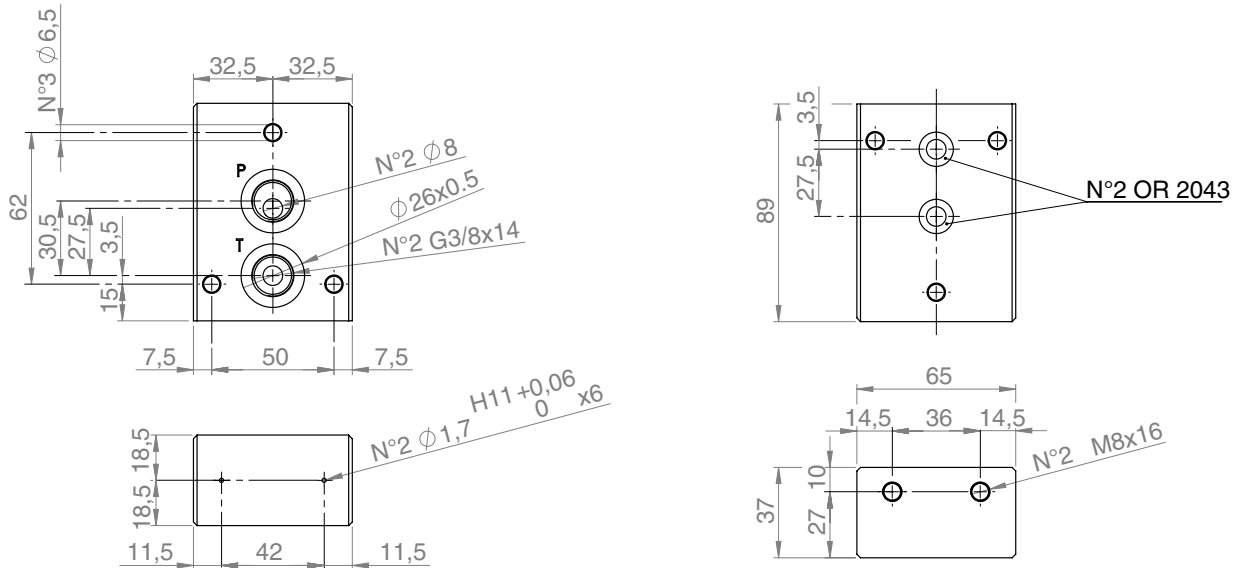

**10 CLOSING PLATE, STACKABLE WITH HDFH-ES**

PD2-AL-HDFH

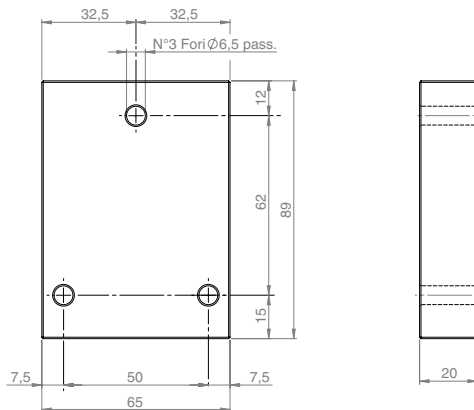

**11 MOUNTING ANGLES KIT TYPE MAF-HDFH**

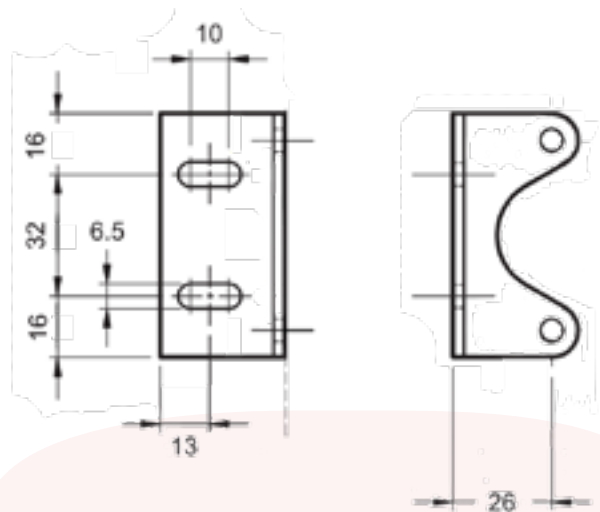

**12 SPECIAL COIL CONNECTIONS**

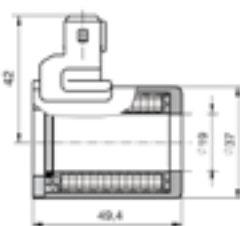

AMP = Amp Junior Timer  
vertical configuration

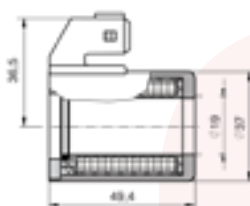

AMPX

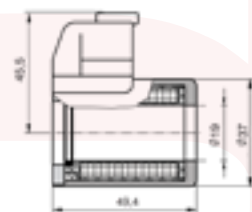

D = Deutsch

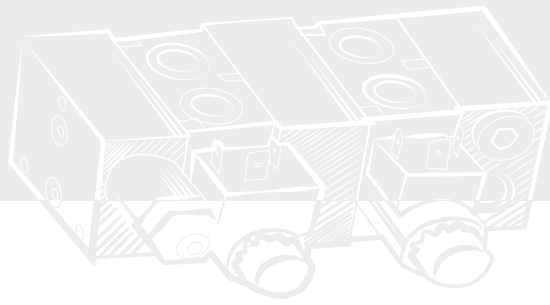



# SUMMARY

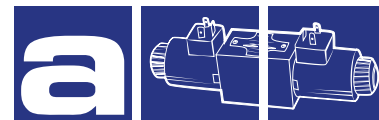

## **2** CETOP 02

DIRECTIONAL CONTROL VALVES SOLENOID OPERATED

**HD2-EI-\*** 0001

---

DIRECTIONAL CONTROL VALVES SOLENOID OPERATED

**HD2-ES-\*** 0004

---

DIRECTIONAL CONTROL VALVES LEVER OPERATED

**HD2-LO-\*** 0008

---

STACKABLE VALVES FLOW RESTRICTOR

**AM2-FO-\*** 0011

---

STACKABLE VALVES FLOW CONTROL

**AM2-FC-\*** 0013

---

STACKABLE VALVES FLOW CONTROL

**AM2-FX-\*** 0015

---

STACKABLE CHECK VALVES

**AM2-CO-\*/10** 0017

---

STACKABLE CHECK VALVES

**AM2-CO-\*/20** 0019

---

STACKABLE PILOT OPERATED CHECK VALVES

**AM2-CP-\*** 0021

---

STACKABLE PRESSURE RELIEF VALVES

**AM2-MO-\*** 0023

---

MODULAR VALVES PRESSURE REDUCING

**AM2-RO-\*** 0025

---

**aidro**  
hydraulics



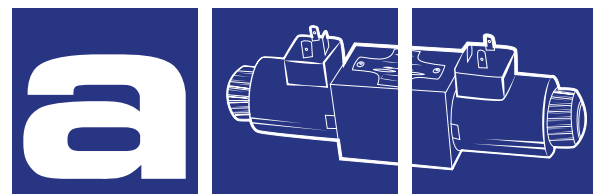

## DIRECTIONAL CONTROL VALVES SOLENOID OPERATED

### HD2-EI-\*

25 l/min - 32 MPa (320 bar)

#### 1 DESCRIPTION

Valves HD2-EI are directional control valve with subplate mounting interface acc. to ISO 4401, DIN 24340 (CETOP 02).

The design of the body is a three chamber casting for production cost saving and low pressure drops.

The valve is available with interchangeable plastic DC solenoids, also for AC power supply using connectors with a built-in rectifier bridge.

In the standard version, the valve housing is phosphated for 240 h salt spray protection acc. to ISO 9227. Enhanced surface protection for mobile sector available (ISO 9227, 520 h salt spray).

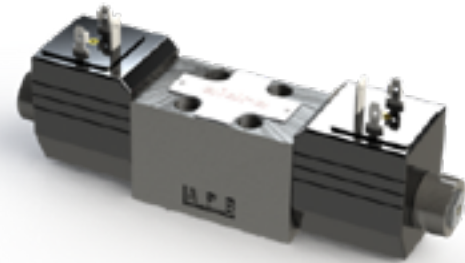

#### 2 ORDERING CODE

(1)	(2)	(3)	(4)	(5)	(6)
HD2	-	EI	-	-	/ 10

(1) HD2: 4-way directional control valve CETOP 02

(2) EI: electrically controlled

(3) Spool type (see 4)

-number is the main spool type

-letter is solenoid and spring arrangement:

C: 2 solenoids, spool is spring centered (3 position)

LL: 1 solenoid (a), spool is spring offset (2 position, end to end)

ML: 1 solenoid (a), spool is spring offset (2 position, middle to end)

(4) Code reserved for option and variants:

b: only for version LL and ML, solenoid b installed (instead of solenoid a)

ZN: Zinc Nichel surface treatment

(5) Electric voltage and solenoid coils:

0000: no coils

012C: coils for V12DC

024C: coils for V24DC

110R: coils for V98DC (V110/50 – V115/60 RAC)

220R: coils for V198DC (V220/50 – V230/60 RAC)

(6) Design number (progressive) of the valves

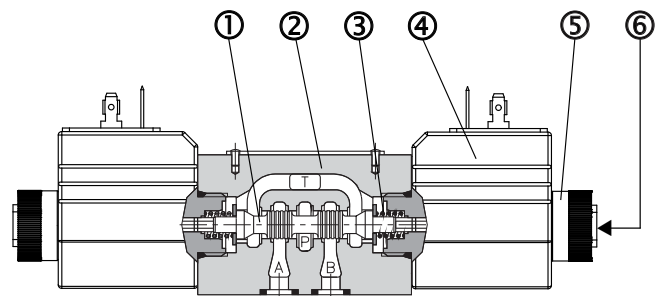
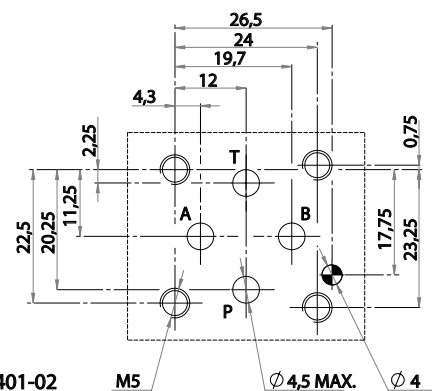

Spools, springs and solenoids combination permit to obtain almost every type of ports (P, A, B, T) connection and sequence. For almost all types of solenoids/springs combination and for all type of spools (with the exception of spool 4), when solenoid "a" is energized, hydraulic connections are P-->B and A-->T; to obtain P-->A and B-->T solenoid "b" must be energized. The hydraulic connections that are obtained in the "central" (neutral) position when solenoids are not energized is the characteristic mark of the spool shape and from it derives its identification number: 0 = P, A, B, T connected 1 = P, A, B, T closed 3 = P closed, A, B, T, connected for other types see 4

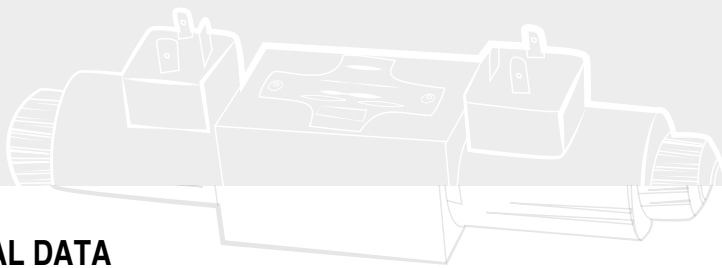

### 3 TECHNICAL DATA

Maximum nominal flow	20 l/min	<b>Electric characteristic:</b> Valves HD2-EI-* are operated by solenoid that are energized: - directly from a D.C. voltage supply: V 12 DC (012C) V 24 DC (024C) - by the use of connectors that incorporate a full wave bridge rectifier, from A.C. voltage supply: V 110/50, V 115/60 or V115/50 (110R) V 220/50, V 230/60 or V 230/50 (220R) All connectors must conform to ISO 4400 (DIN 43650) and electric circuitry must be able to carry the following rated current values: V 12 DC= 2,4 A V 24 DC= 1,2 A V 110 R= 0,30 A V 220 R= 0,15 A Permissible supply voltage variation: +5% -10%
Maximum rec. flow rate	25 l/min	
Maximum nominal pressure (P, A, B)	25 MPa (250 bar)	
Maximum pressure	32 MPa (320 bar)	
Maximum pressure at T port	16 MPa (160 bar)	
Pressure drops	see [5]	
Protection to DIN 40050	IP 65	
Duty cycle	100%	
Service life	≥ 10 <sup>7</sup> cycles	
Installation and dimensions	see [7]	
Mass	approx 0,8/1,1kg	

### 4 SPOOL IDENTIFICATION AND INTERMEDIATE POSITION TRANSITORIES

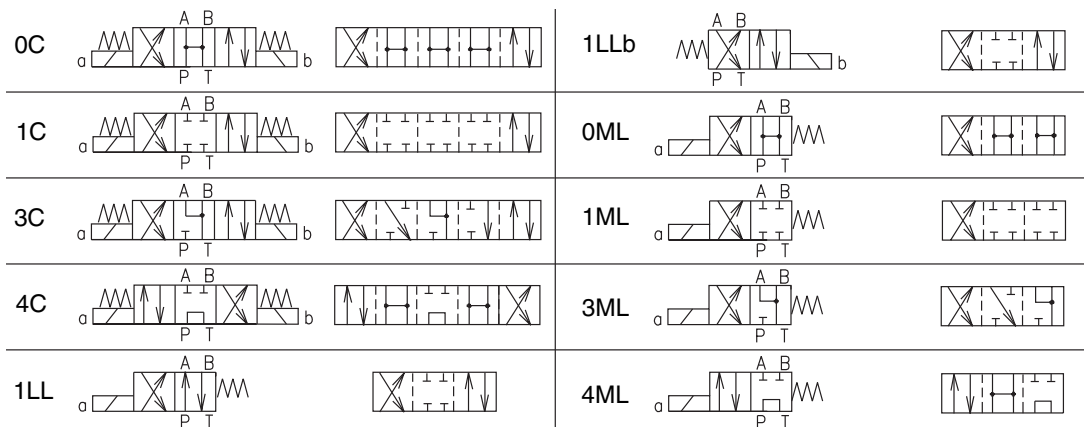

### 5 TYPICAL DIAGRAMS

Typical  $\Delta p$ -Q curves for valves HD2 -EI-\* in standard configuration, with mineral oil at 36 cSt and at 50°C for flow P -> A/B, A/B -> T

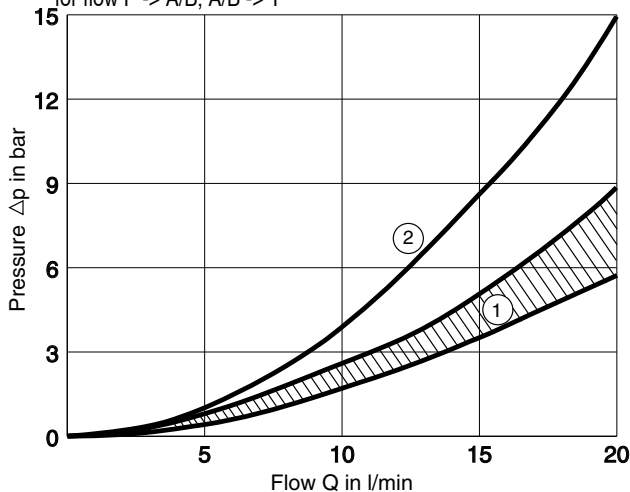

- ①= all spool: P -> A/B and A/B -> T
- ②= spool 4: P -> A/B and P->T

### 6 OPTIONS

OPTION S CALIBRATED ORIFICE ON P PORT

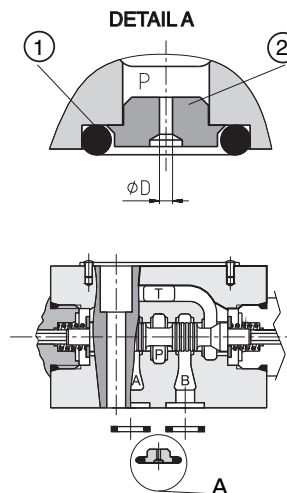

Option "S" is represented by elements ②, suitably shaped to be inserted on P port of the solenoid valve, having a calibrated orifice (of various sizes) able to restrict, at the requested  $\Delta p$  value, the flow rate entering the solenoid valve.

Those elements have the following orifice diameter:

- 2S - 08 -> D=0,8 mm
- 2S - 10 -> D=1 mm
- 2S - 12 -> D=1,2 mm
- 2S - 15 -> D=1.5 mm

and are kept sealed on the P port of the valve by an OR ① of 7,65x1,78 mm sizes (example OR 107-2031).

## 7 INSTALLATION DIMENSIONS (mm)

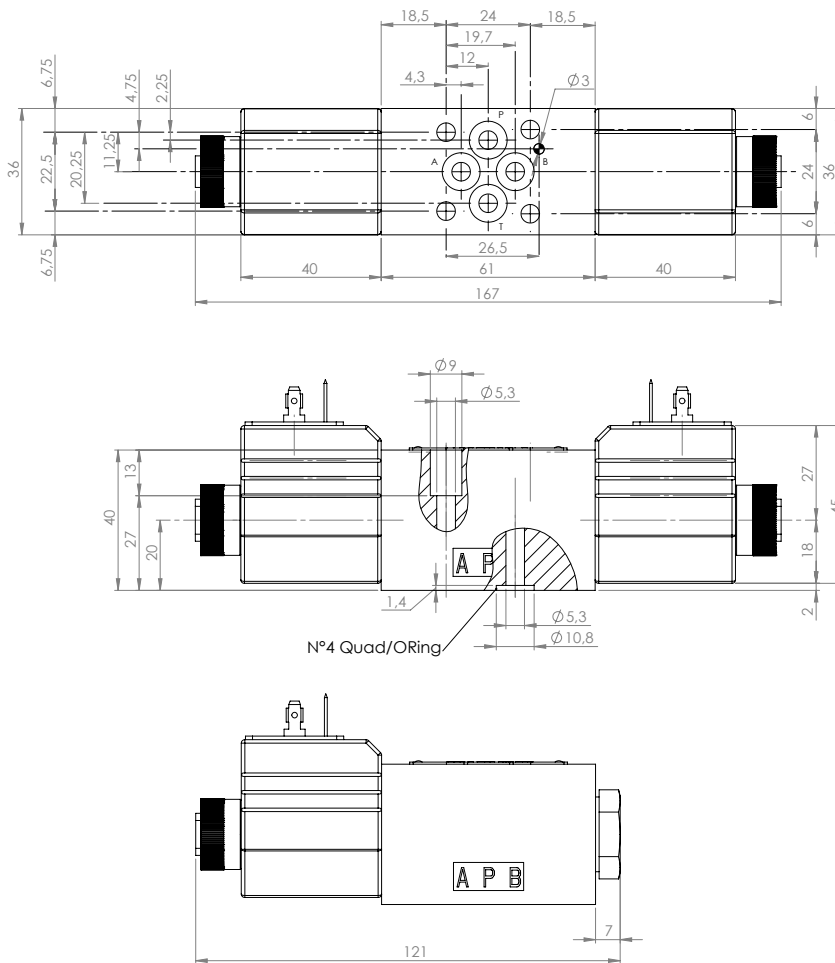

All valves HD2-\* conform with ISO and CETOP specifications for mounting surface dimensions and for valves height. When assembled to its mounting plate valve HD2 - \* must be fastened with 4 bolts M5x35 (or M5x\*\* according to the number of modules) tightened at 8 Nm torque. Leakage between valve and mounting surface is prevented by the positive compression on their seats of 4 seals of QUAD/O Ring type 7,65x1,68x1,68. Connections to the electric supply is made by standard 3-PIN connectors, according to ISO 4400 (DIN 43650). Connectors can be with different cable exit size (PG9, PG11) and beside of the plain connecting function they may incorporate various features like:

- signal led
- bridge rectifier for AC supply
- voltage surge suppressor, etc.

## 8 HYDRAULIC FLUIDS

Seals and materials used on standard valves HD2-\* are fully compatible with hydraulic fluids of mineral oil base, upgraded with antifoaming and antioxidantizing agents. The hydraulic fluid must be kept clean and filtered to ISO 4406 class 19/17/14, or better, and used in a recommended viscosity range from 10 cSt to 60 cSt.



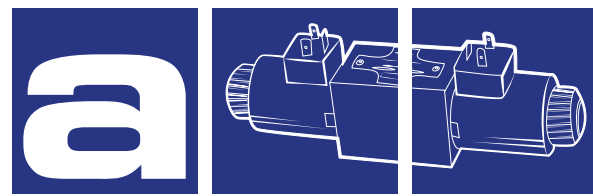

## DIRECTIONAL CONTROL VALVES SOLENOID OPERATED

### HD2-ES-\*

30 l/min - 32 MPa (320 bar)

#### 1 DESCRIPTION

Valves HD2-ES are directional control valve with subplate mounting interface acc. to ISO 4401, DIN 24340 (CETOP 02).

The design of the body is a three chamber casting for production cost saving and low pressure drops.

The valve is available with interchangeable metallic DC solenoids, also for AC power supply using coils with a built-in rectifier bridge.

In the standard version, the valve housing is phosphated for 240 h salt spray protection acc. to ISO 9227. Enhanced surface protection for mobile sector available (ISO 9227, 520 h salt spray).

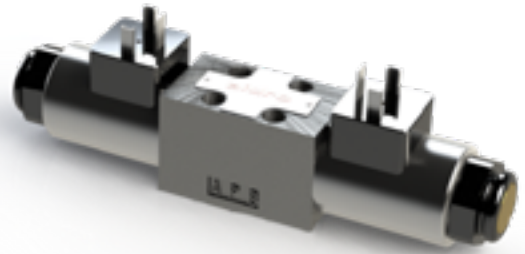

#### 2 ORDERING CODE

(1)	(2)	(3)	(4)	(5)	(6)
HD2	-	ES	-	-	/ 11

(1) HD2: 4-way directional control valve CETOP 02- Pressure 32 MPa (320 bar)

(2) ES: electrically controlled standard

(3) Spool type (see 4)

-number is the main spool type

-letter is solenoid and spring arrangement:

C: 2 solenoids, spool is spring centered (3 position)

N: 2 solenoids, spool is detented (2 position)

LL: 1 solenoid (a), spool is spring offset (2 position, end to end)

ML: 1 solenoid (a), spool is spring offset (2 position, middle to end)

LM: 1 solenoid (a), spool is spring offset (2 position, end to middle)

(4) Code reserved for option and variants:

b: only for version LL, ML, LM solenoid b installed (instead of solenoid a)

K: protruding emergency pins, protected by rubber caps (see 9)

S\*: calibrated orifice on P port (see 10)

ZC: zinc plated valve (see 12)

ZN: Zinc nichel plated body (see 12)

(5) Electric voltage and solenoid coils:

0000: no coils

012C: coils for V12DC

024C: coils for V24DC

115A: coils for V110/50 – V115/60 AC

230A: coils for V220/50 – V230/60 AC

(6) Design number (progressive) of the valves

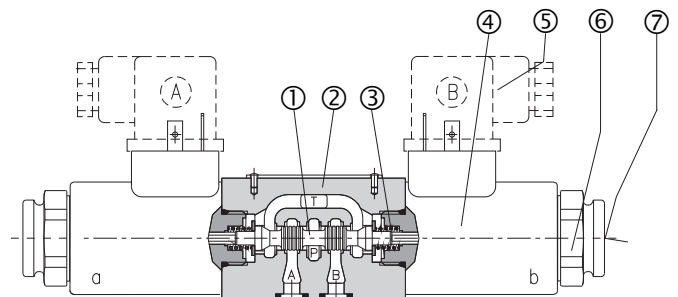
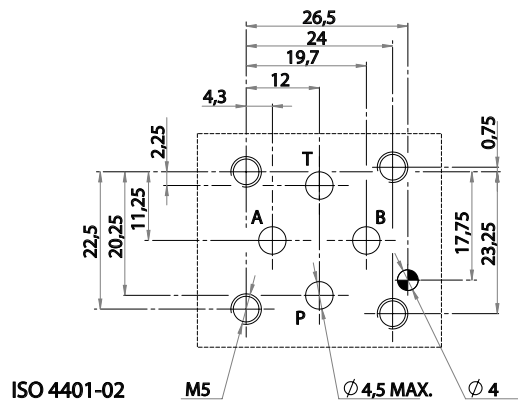

Spools, springs and solenoids combination permit to obtain almost every type of ports (P, A, B, T) connection and sequence. For almost all types of solenoids/springs combination and for all type of spools (with the exception of spool 4), when solenoid "a" is energized, hydraulic connections are P-->B and A-->T; to obtain P-->A and B-->T solenoid "b" must be energized. The hydraulic connections that are obtained in the "central" (neutral) position when solenoids are not energized is the characteristic mark of the spool shape and from it derives its identification number: 0 = P, A, B, T connected 1 = P, A, B, T closed 3 = P closed, A, B, T, connected for other types see 4

### 3 TECHNICAL DATA

Maximum nominal flow	0,5 dm <sup>3</sup> /s (30 l/min)	<b>Electric characteristics:</b>  Valves HD2 -ES-* are operated by solenoid that are energized: - directly from a D.C. voltage supply: V 12 DC (012C) V 24 DC (024C) - by the use of coils that incorporate a full wave bridge rectifier, from A.C. voltage supply: V 110/50 (V 115/60) =115 A V 220/50 (V 230/60) =230 A  All standard valves are to be fitted with connectors conform to ISO 4400 (DIN 43650) and electric circuitry must be able to carry the following rated current values: V 12 DC = 2,4 A V 24 DC = 1,2 A V 110/50 = 0,30 A V 220/50 = 0,15 A  Permissible supply voltage variation: +10% -10%
Maximum rec. flow rate	see [6]	
Maximum nominal pressure (P, A, B)	32 MPa (320 bar)	
Maximum pressure at T port	21 MPa (210 bar)	
Pressure drops	see [5]	
Protection to DIN 40050	IP 65	
Duty cycle	100%	
Service life	≥ 10 <sup>7</sup> cycles	
Installation and dimensions	see [7]	
Mass	approx 1,0/1,4 kg	

### 4 SPOOL IDENTIFICATION AND INTERMEDIATE POSITION TRANSITORIES

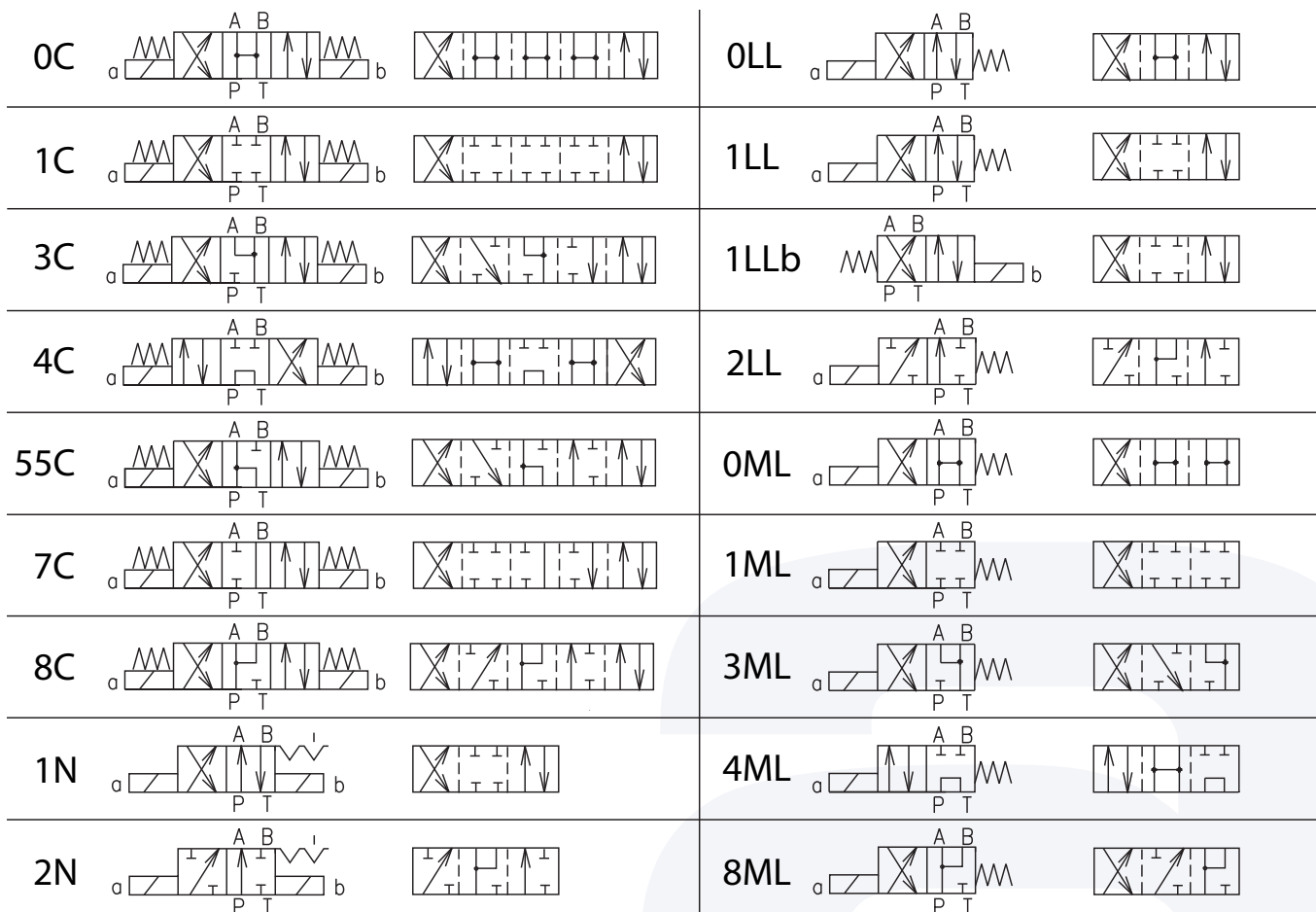

## 5 TYPICAL DIAGRAMS

Typical  $\Delta p$ -Q curves for valves HD2-ES-\* in standard configuration, with mineral oil at 36 cSt and at 50°C for flow P -> A/B, A/B -> T

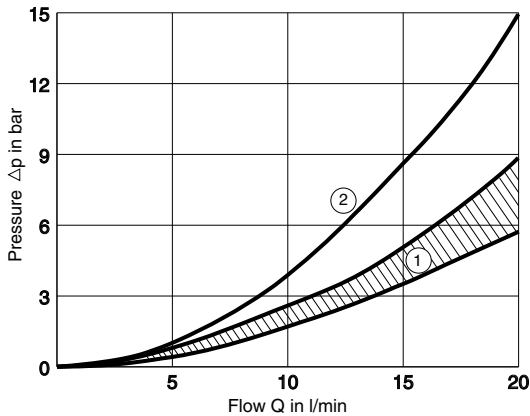

- ①=all spool P -> A/B and A/B -> T ; P -> T spool 4 and 0  
 ②= P -> A/B spool 4 ; A/B -> T spool 4

## 6 HYDRAULIC LIMITS OF USE

P/Q characteristic limits for safe use of HD2-ES-\* solenoid operated valves. Limit curves apply to solenoid valves energized with rated voltage - 5% and flushed with hydraulic fluid with properties according to 8.

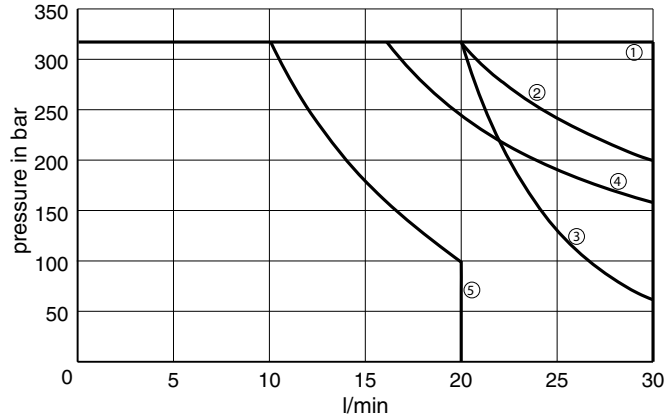

- ①= HD2 - ES - 0C; - 1C; - 1N; - 3C; - 8C; - 0ML; - 1LL; - 1ML; - 3ML; - 8ML  
 ②= HD2 - ES - 2N; - 7C  
 ③= HD2 - ES - 0LL  
 ④ = HD2 - ES - 4C; - 4ML  
 ⑤ = HD2 - ES - 55C; - 2LL

## 7 INSTALLATION DIMENSIONS (mm)

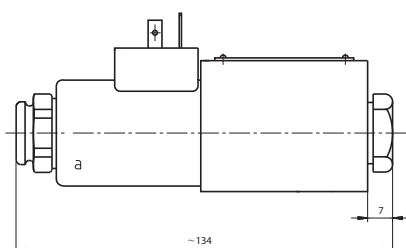
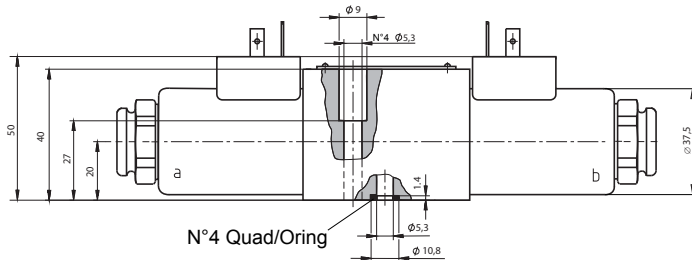
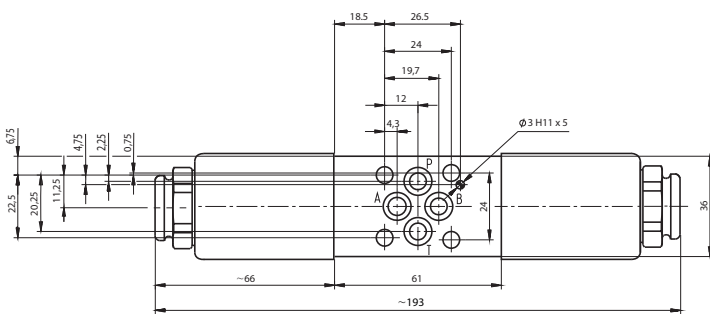

All valves HD2-\* conform with ISO and CETOP specifications for mounting surface dimensions (see 6) and for valves height. When assembled to its mounting plate valve HD2 - \* must be fastened with 4 bolts M5x35 (or M5x\*\* according to the number of modules) tightened at 8 Nm torque.

Leakage between valve and mounting surface is prevented by the positive compression on their seats of 4 seals of QUAD/ O Ring type 7,65x1,68x1,68. Solenoid valves can be supplied without electric coils, as HD2 - ES -\*\*-0000 - .

Coils are supplied separately: standard, 3 electric pins coils are BO2-012C, BO2-024C, BO2-115A and BO2-230A.

Connectors to the electric supply is made:

a) On standard solenoid coils by standard 3-PIN connectors according to ISO 4400 (DIN 43650).

Connectors can be with different cable exit size (PG9, PG11) and beside of the plain connecting function they may incorporate various features like

- signal led
- voltage surge suppressor, etc.

b) On type "AMP" solenoid coils, by connectors conforming to AMP-Timer (see 11 )

## 8 HYDRAULIC FLUIDS

Seals and materials used on standard valves HD2-\* are fully compatible with hydraulic fluids of mineral oil base, upgraded with antifoaming and filtered to ISO 4406 class 19/17/14 or better, and used in a recommended viscosity range from 10 cSt to 60 cSt.

## 9 VERSION "K": EXTENDED EMERGENCY PIN

Solenoid valves according to "K" version have extended emergency actuator pins protruding from the solenoid shape, that permit a quick and easy "Hand operation" of the valves, without the need of any tool. The actuator pin and the end of the solenoid are protected by a flexible rubber cap that makes easy operation and protects from moisture and water splashes.

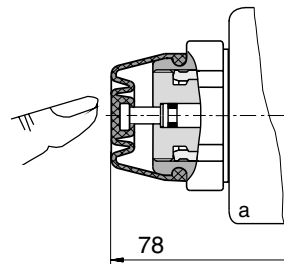

## 10 VERSION "S\*": CALIBRATED ORIFICE ON P PORT

Option "S" is represented by elements ②, suitably shaped to be inserted on P port of the solenoid valve, having a calibrated orifice (of various size) able to restrict, at the requested  $\Delta p$  value, the flow rate entering the solenoid valve. Those elements have the following orifice diameter:

2S - 08 D = 0,8 mm

2S - 10 D = 1

2S - 12 D = 1,2 mm

2S - 15 D = 1,5 mm

and are kept sealed on the P port of the valve by an OR ① of 7,65x1,78 mm sizes (example OR 107-2031)

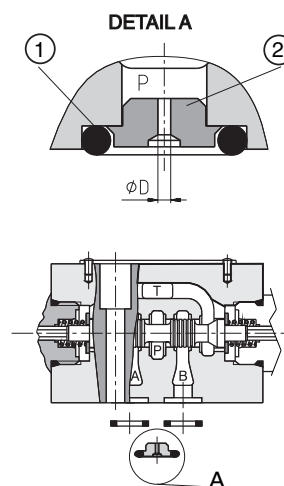

## 11 VERSION "AMP" and VERSION "Deutsch":

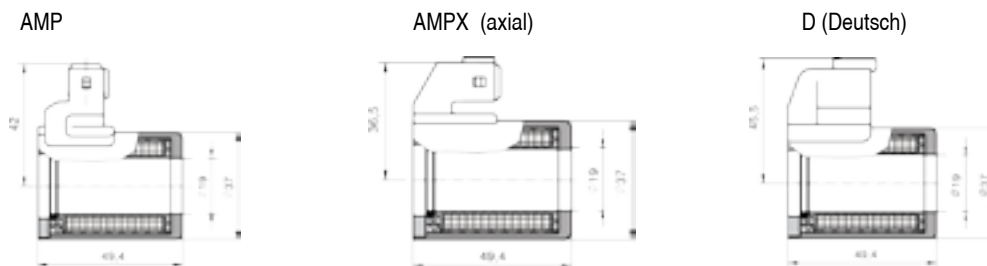

They are typically used on DC mobile application and they are available for many different coltages voltages:

## 12 VERSION "ZC" and VERSION "ZN" ZINC PLATED VALVES

Solenoid valves according to "ZC" version are completely zinc plated and protected against every type of corrosion due to saline ambience or other aggressive chemicals. Zinc thickness are:

on the valve body 10-15  $\mu\text{m}$

on the solenoid tubes 8-12  $\mu\text{m}$

on the solenoid coils 8-12  $\mu\text{m}$

Version ZN (Zinc Nichel) has an higher protection degree which achieve the ISO 9227, 720 h salt spray test requirements

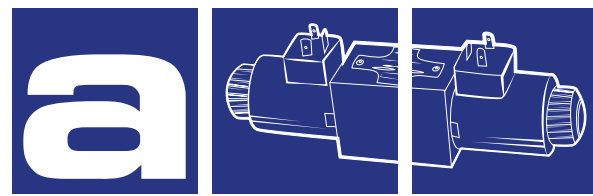

## DIRECTIONAL CONTROL VALVES LEVER OPERATED HD2-LO-\*

30 l/min - 32 MPa (320 bar)

### 1 DESCRIPTION

The hand operated directional control valves are used mainly to control start, stop and direction of fluid. Manual lever and actuating section can be rotated in 90° increments for flexible installation. The directional control valves are being manufactured as two-position and three-position valves (see table with functional symbols). In the standard version, the valve housing is phosphated and steel parts zinc-coated for 240 h salt spray protection acc. to ISO 9227. Enhanced surface protection for mobile sector available (ISO 9227, 520 h salt spray).

### 2 ORDERING CODE

(1)	(2)	(3)	(4)	(5)	(6)
HD2	-	LO	-	-	/ 10

(1) HD2: 4-way directional control valve CETOP 02- Pressure 32 MPa (320bar)

(2) LO: standard lever operated

(3) Spool type (see 4)

-number is the main spool type

-letter is lever and spring arrangement:

C: spool is spring centered (3 position)

D: spool is detented (3 position)

N: spool is detented (2 position, end to end)

LL: spool is spring offset (2 position, end to end)

ML: spool is spring offset (2 position, middle to end)

(4) Code reserved for option and variants:

b: level mechanism on B port side only for version LL, ML

(5) Code reserved for special variants

(6) Design number (progressive) of the valves

The hydraulic connections that are obtained in the "central" (neutral) position is the characteristic mark of the spool shape and from it derives its identification number: 0 = P,A,B,T connected 1 = P,A,B,T closed 3 = P closed, A,B,T connected for other types see All standard valves have the lever mechanism on the side of port "A". All 2 position, spring offset, standard valves are operated by pulling the lever. All 3 position standard valves have a +/15° angle stroke of the lever. Average effort required on the lever to operate the valve: less than 50 N. Other spool/spring/detent/lever position combinations are possible and they are indicated by a xxx 3 digits code.

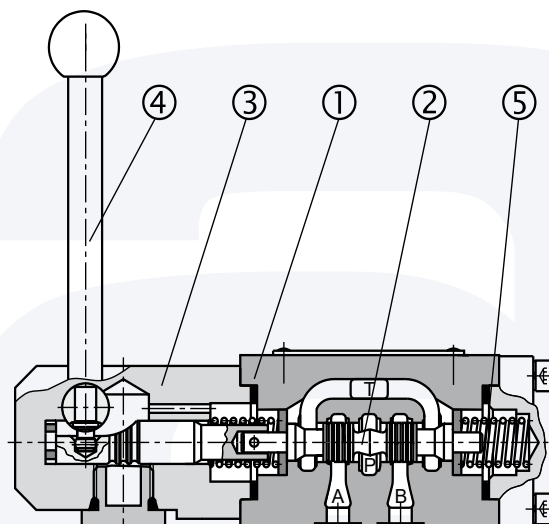
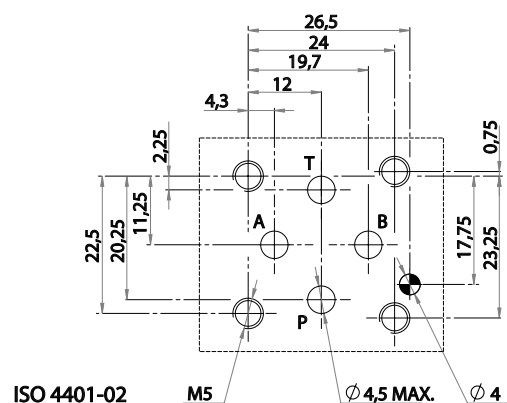
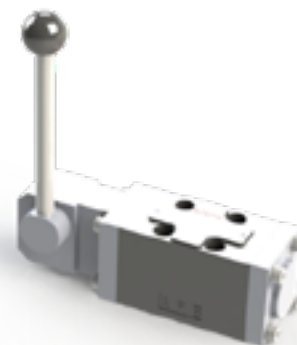

### 3 TECHNICAL DATA

Maximum nominal flow	30 l/min	Pressure drops	see 5
Maximum rec. flow rate	30 l/min	Installation and dimensions	see 6
maximum nominal pressure (P,A,B)	32 MPa (320 bar)	Mass	approx 1 kg
Pressure at T port	10 MPa (100 bar)		
Exception C54 and C55	10 l/min at 320 bar 30 l/min at 100 bar		

### 4 SPOOL IDENTIFICATION AND INTERMEDIATE POSITION TRANSITORIES

1C			1D		
4C			4D		
0C			0D		
8C			8D		
3C			3D		
7C			7D		
54C			54D		
55C			55D		
33C			33D		
31C			31D		
1LL			1N		
2LL			2N		
0LL			0N		

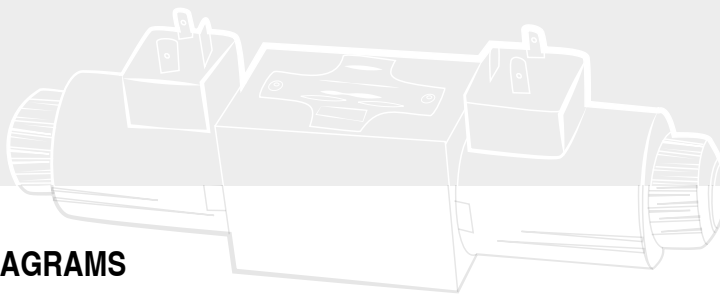

## 5 TYPICAL DIAGRAMS

Δp-Q characteristics

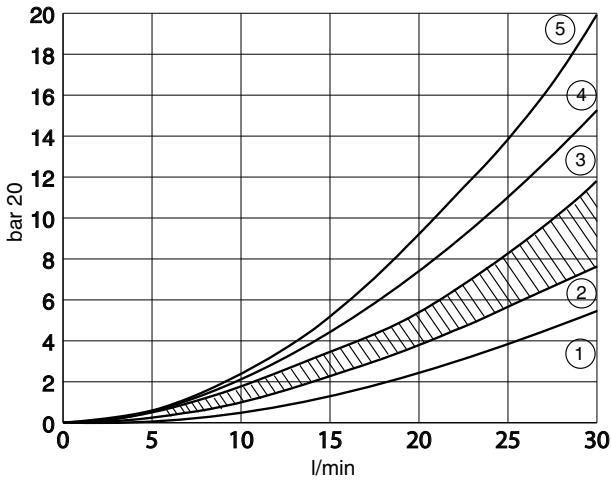

- P-> A,P-> B spool 0,8  
 ① ③ spool 0, 1, 2, 3, 7, 54, 55, 33, 31  
 ② and P->T spool 4
- ④ A->T,B->T spool 4 P->T spool 54,55  
 ⑤ P->A,P->B spool 4

## 6 INSTALLATION DIMENSIONS (mm)

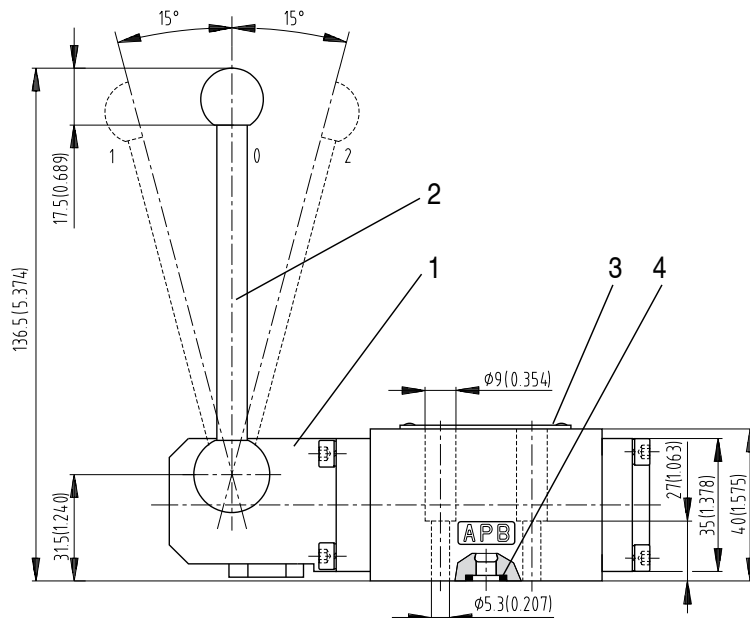
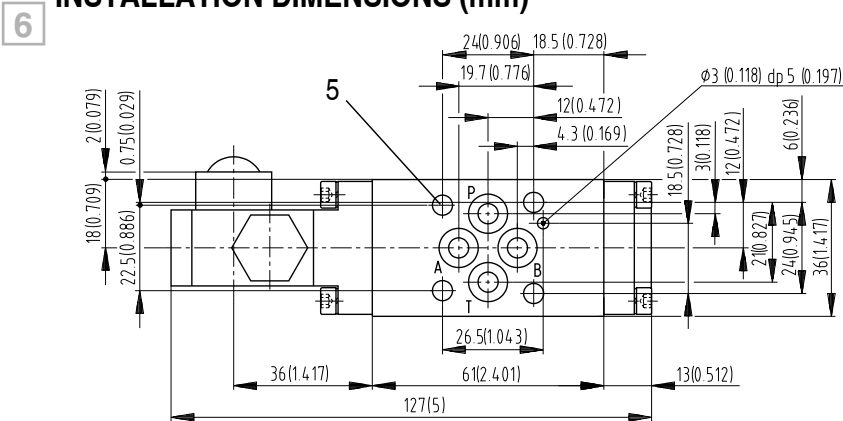

- 1 Actuating section
- 2 Hand lever
- 3 Name plate
- 4 Square ring 7.65x1.68 (4 pcs.)  
supplied with valve
- 5 4 mounting holes

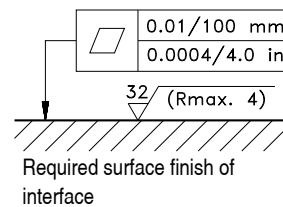

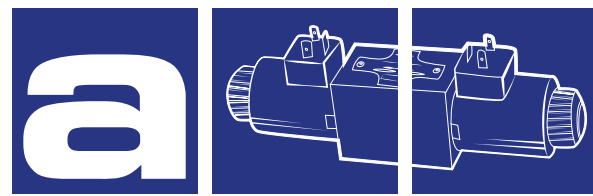

## STACKABLE VALVES FLOW RESTRICTOR

### AM2-FO-\*

30 l/min - 32 MPa (320 bar)

#### 1 DESCRIPTION

Stackable valve CETOP 2 with flow restrictor function. It is possible to control the lines A, B or AB simply turning the side screws.  
On demand it is possible to have also the fine control option.



#### 2 ORDERING CODE

(1)	(2)	(3)	(4)	(5)	(6)
AM2	-	FO	-	-	/ 10

- (1) AM2: stackable valve CETOP 02- Pressure 32 MPa (320bar)
- (2) FO: flow restrictor valves with two-way control
- (3) Service lines where the controls operate:  
 AB: controls on A and B. Fluid flows restricted A <-> A and B <-> B  
 A : flow is restricted A <-> A; free on B, P and T  
 B : flow is restricted B <-> B; free on A, P and T
- (4) Flow control characteristics  
 no designation : standard control  
 W: fine and sensitive control
- (5) Code reserved for special variants ( materials, seals, surface treatments etc.)
- (6) Design number (progressive) of the valves

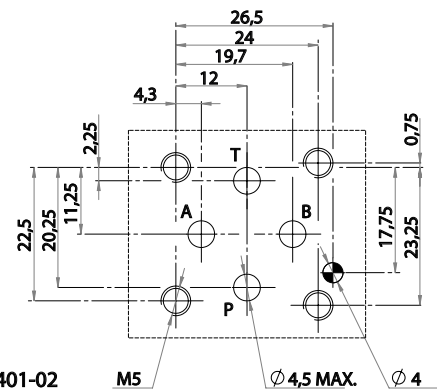

ISO 4401-02

#### AM2-FO-AB

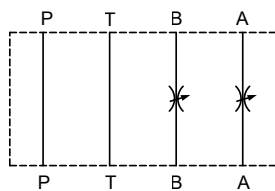

#### AM2-FO-A

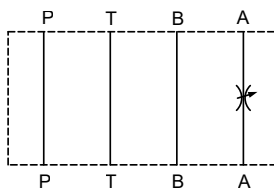

#### AM2-FO-B

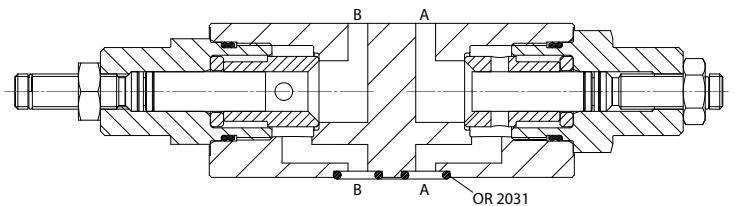
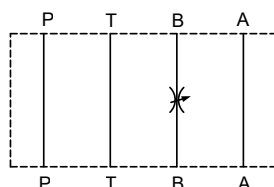



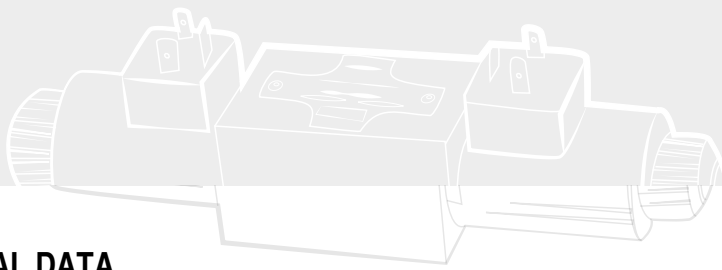

### 3 TECHNICAL DATA

Maximum nominal flow	32 l/min	<b>Control of the flow:</b>  The control is made by throttling through variable orifices obtained on sleeve and partially obstructed by throttling axis. Depending on the various sleeve/axis combination, the control adjustment is: - (standard) : orifices area is reduced from 100% (*) to 0% with 6 complete turns of the adjustment screw. W (fine and sensitive): from 100% (*) to 0% with 8 complete turns - special variant (*) 100% approx: Q=0.5 dm <sup>3</sup> /s (30 l/min) at Δp=1MPa (10 bar)  The axis is shifted to increase throttling by unlocking its nut and turning clock wise the adjustment screw. Suitable mechanical stops prevent dangerous manoeuvring.
Maximum rec. flow rate	0,5 dm <sup>3</sup> /s (30 l/min)	
maximum nominal pressure	32 MPa (320 bar)	
Pressure drops	see 4	
Installation and dimensions	see 5	
Mass	approx 0,8 kg	

### 4 TYPICAL DIAGRAMS

Typical Δp-Q curves for valves AM2-FO-\* in standard configuration, with mineral oil at 36 cSt and at 50° C with throttling axis at full retraction

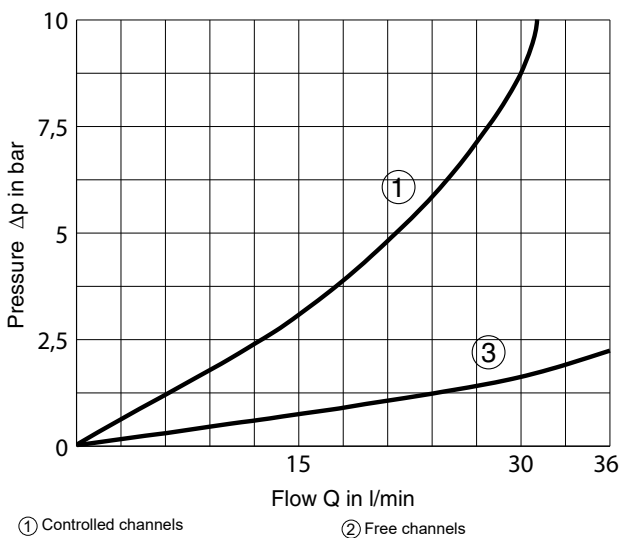

### 5 INSTALLATION DIMENSIONS (mm)

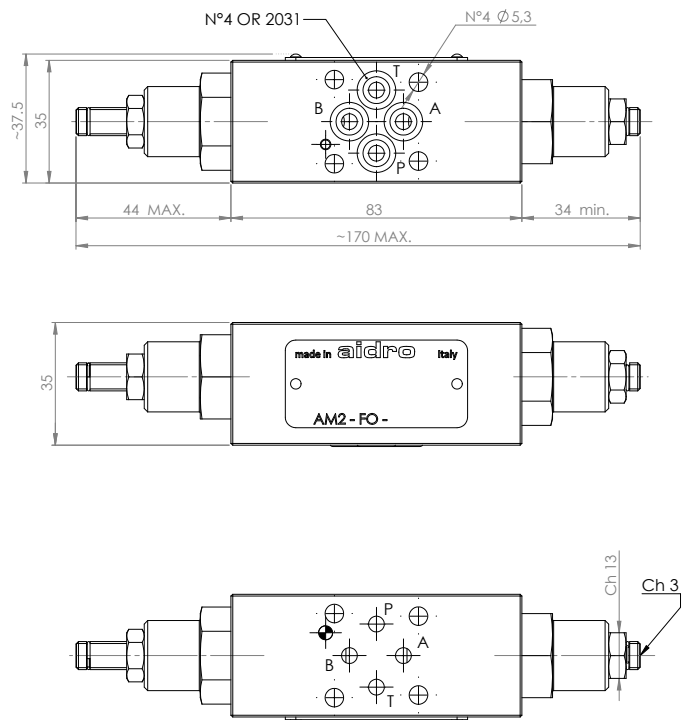

### 6 HYDRAULIC FLUIDS

Seals and materials used on standard valves AM2-\* are fully compatible with hydraulic fluids of mineral oil base, upgraded with antifoaming and antioxidantizing agents. The hydraulic fluid must be kept clean and filtered to ISO 4406 class 19/17/14, or better, and used in a recommended viscosity range from 10 cSt to 60 cSt.

All stackable valves AM2-FO conform with ISO and CETOP specifications for mounting surface dimensions (see also front page). Valves height 35 mm. Leakage between valve and mounting surface is prevented by the positive compression on their seats of 4 seals of OR type. All valves have on their "mounting" surface a ø 4 mm cylindrical hole and are equipped on their "seals" surface by a ø 3 mm locating pin, to conform with the norms. In case of necessity, the pin can be easily removed.

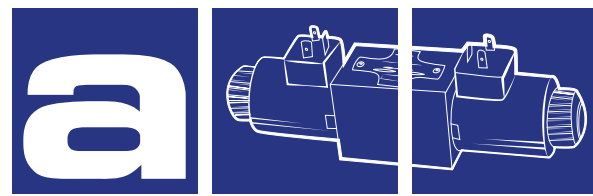

## STACKABLE VALVES FLOW CONTROL

### AM2-FC-\*

30 l/min - 32 MPa (320 bar)

#### 1 DESCRIPTION

Stackable valve CETOP 2 with meter out control (referred to the hydraulic actuator). It is possible to control the lines A, B or AB simply turning the side screws.

On demand it is possible to have also the fine control option.

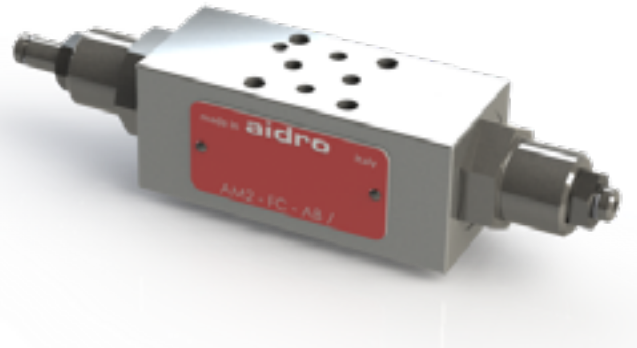

#### 2 ORDERING CODE

(1)	(2)	(3)	(4)	(5)	(6)
AM2	-	FC	-	-	/ 10

- (1) AM2: stackable valve CETOP 02- Pressure 32 MPa (320 bar)
- (2) FC: one-way flow control valves with meter-out control (referred to the hydraulic actuator)
- (3) Service lines where the controls operate:
  - AB : controls on A and B. Fluid flows unrestricted A -> A1, and flow is controlled from A1 -> A and B1 -> B
  - A : flow is controlled from A1 -> A; free on B, P and T
  - B : flow is controlled from B1 -> B; free on A, P and T
- (4) Flow control characteristics for A1 -> A and B1 -> B and check valve opening pressure (Pm) for flow A -> A1 and B -> B1
  - no designation: standard control and Pm approx 0.04 MPa (0.4 bar)
  - W : fine and sensitive control
  - 4 : Pm approx 0.4 MPa (4 bar)
- (5) Code reserved for special variants (materials, seals, surface treatments etc.).
- (6) Design number (progressive) of the valves

Fluid flows freely on P and T lines; on service lines A and/or B with controls, fluid flows from A -> A1 (and/or B ->B1) overcoming the force of spring acting on sleeve; fluid flows from A1 ->A (and/or B1 ->B) through orifices of sleeve which is pushed against its seat; the throttling axis, which is shifted by screwing it and locked by its nut, partially obstructs the control orifices, thus making the flow rate entirely dependent upon the available pressure drop.

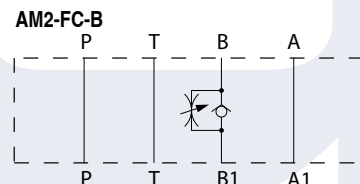
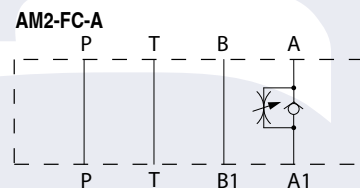
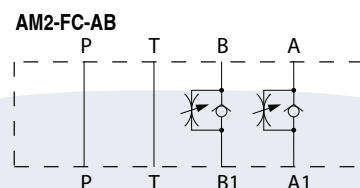
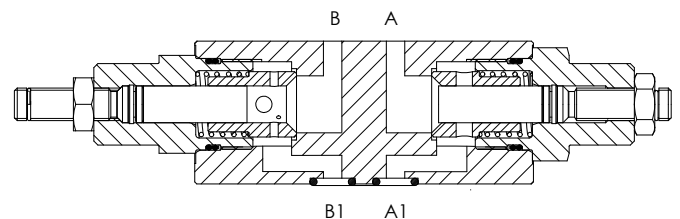
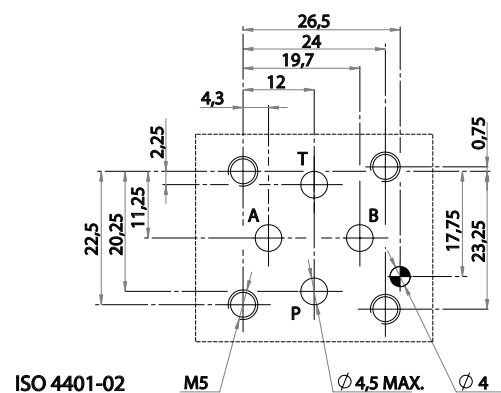

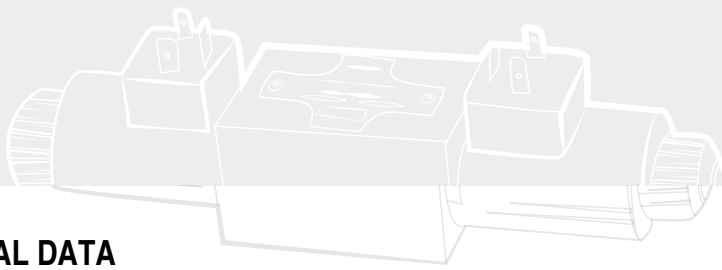

### 3 TECHNICAL DATA

Maximum nominal flow	32 l/min	Control of the flow: The control is made by throttling from A1 -> A (and/or B1 ->B) through variable orifices. Depending on the various sleeve/axis combination, the control adjustment is: no designation: standard, orifices area is reduced from 100% (*) to 0% with 6 complete turns of the adjustment screw W (fine and sensitive): from 100% (*) to 0 with 8 complete turns - special variant (*)100 approx: Q=0,5dm <sup>3</sup> /s (30l/min) at Δp= 1MPa (10bar)
Maximum rec. flow rate	30 l/min	
maximum nominal pressure	32 MPa (320 bar)	
Pressure drops	see 5	
Installation and dimensions	see 7	
Mass	approx 0,8 kg	

### 4 TYPICAL DIAGRAMS

Typical Δp-Q curves for valves AM2-FC-AB in standard configuration, with mineral oil at 36 cSt and at 50°C with throttling axis at full retraction.

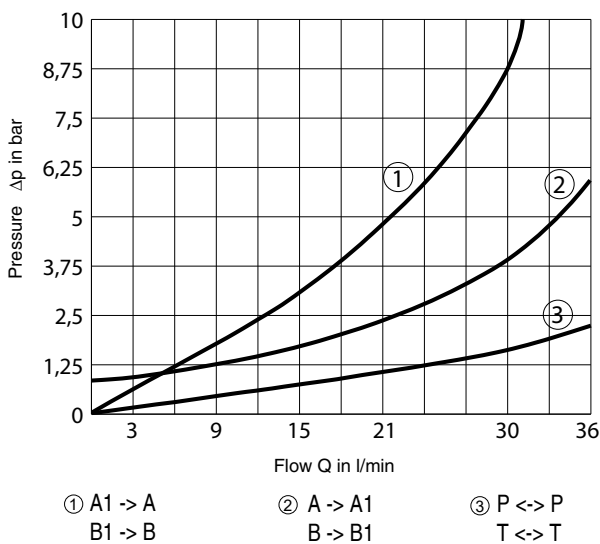

### 5 INSTALLATION DIMENSIONS (mm)

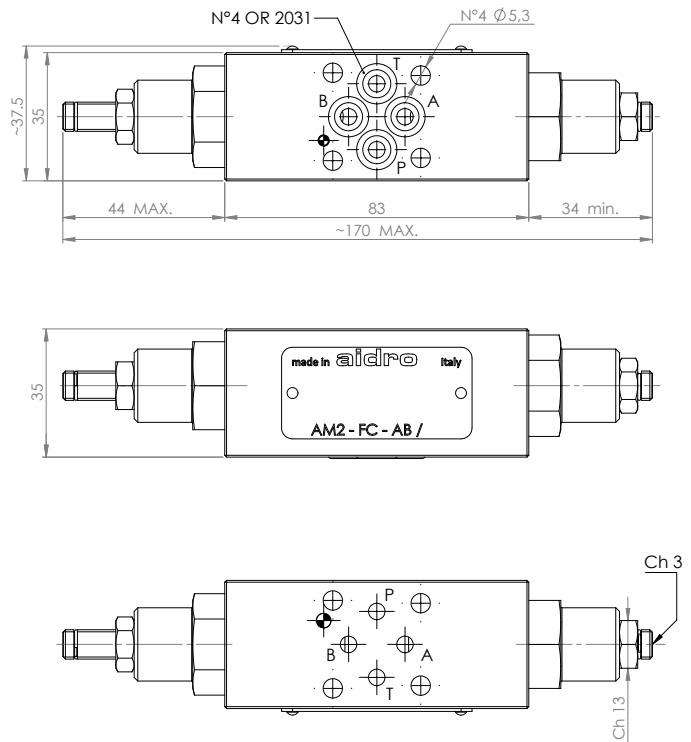

### 6 HYDRAULIC FLUIDS

Seals and materials used on standard valves AM2-\* are fully compatible with hydraulic fluids of mineral oil base, upgraded with antifoaming and antioxidizing agents. The hydraulic fluid must be kept clean and filtered to ISO 4406 class 19/17/14, or better, and used in a recommended viscosity range from 10 cSt to 60 cSt.

All stackable valves AM2-FC-\* conform with ISO and CETOP specifications for mounting surface dimensions (see also front page). Valves height 35 mm. Leakage between valve and mounting surface is prevented by the positive compression on their seats of 4 seals of OR type. All valves have on their "mounting" surface a ø 4 mm cylindrical hole and have on their "seals" surface a ø 3 mm cylindrical hole, conform with ISO and CETOP norms.

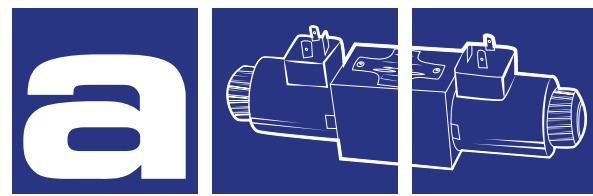

## STACKABLE VALVES FLOW CONTROL

### AM2-FX-\*

30 l/min - 32 MPa (320 bar)

#### 1 DESCRIPTION

Stackable valve CETOP 2 with meter in control (referred to the hydraulic actuator). It is possible to control the lines A, B or AB simply turning the side screws.

On demand it is possible to have also the fine control option.



#### 2 ORDERING CODE

(1)	(2)	(3)	(4)	(5)	(6)	
AM2	-	FX	-	-	/	10

- (1) AM2: stackable valve CETOP 02- Pressure 32MPa (320bar)
- (2) FX: one-way flow control valves with meter-in control (referred to the hydraulic actuator)
- (3) Service lines where the controls operate:
  - AB: controls on A and B. Fluid flows unrestricted A1 -> A, and B1 -> B and flow is controlled from A -> A1 and B -> B1
  - A : flow is controlled from A -> A1; free on B, P and T
  - B : flow is controlled from B -> B1; free on A, P and T
- (4) Flow control characteristics for A -> A1 and B -> B1 and check valve opening pressure (Pm) for flow A1-> A and B1 -> B
  - no designation : standard control and Pm approx 0.04 MPa (0.4 bar)
  - W: fine and sensitive control
  - 4 : Pm approx 0.4 MPa (4 bar)
- (5) Code reserved for special variants (materials, seals, surface treatments etc.).
- (6) Design number (progressive) of the valves

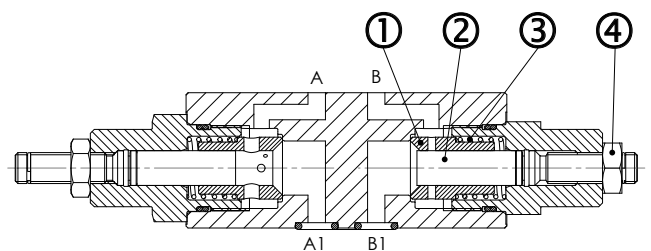
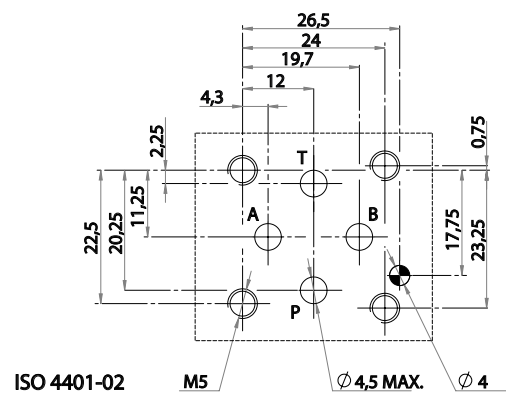

Fluid flows freely on P and T lines; on service lines A and/or B with controls, fluid flows from A-> A1 (and/or B -> B1) overcoming the force of spring acting on sleeve; fluid flows from A1 -> A (and/or B1-> B) through orifices of sleeve which is pushed against its seat; the throttling axis which is shifted by screwing it and locked by its nut, partially obstructs the control orifices, thus making the flow rate entirely dependent upon the available pressure drop.

AM2-FX-AB

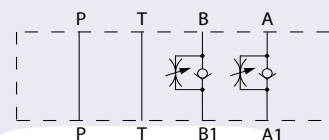

AM2-FX-A

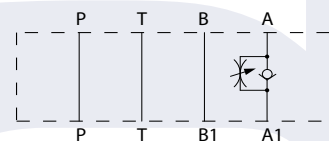

AM2-FX-B

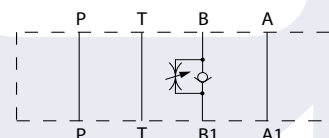

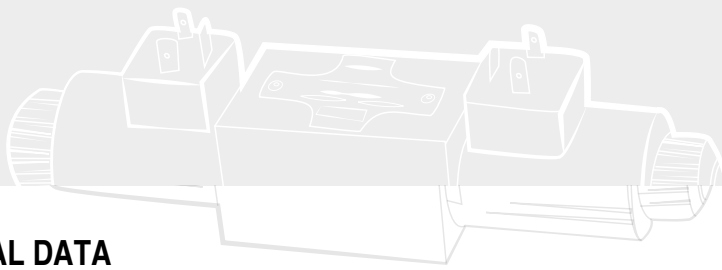

### 3 TECHNICAL DATA

Maximum nominal flow	32 l/min	Control of the flow: The control is made by throttling from A1 -> A (and/or B1 ->B) through variable orifices. Depending on the various sleeve/axis combination, the control adjustment is: no designation: standard, orifices area is reduced from 100% (*) to 0% with 6 complete turns of the adjustment screw W (fine and sensitive): from 100% (*) to 0% with 8 complete turns - special variant (*)100 approx: Q=0,5dm³/s (30l/min) at Δp= 1MPa (10bar)
Maximum rec. flow rate	30 l/min	
maximum nominal pressure	32 MPa (320 bar)	
Pressure drops	see 4	
installation and dimensions	see 5	
Mass	approx 0,8 kg	

### 4 TYPICAL DIAGRAMS

Typical Δp-Q curves for valves AM2 -FX-AB in standard configuration, with mineral oil at 36 cSt and at 50°C with throttling axis at full retraction.

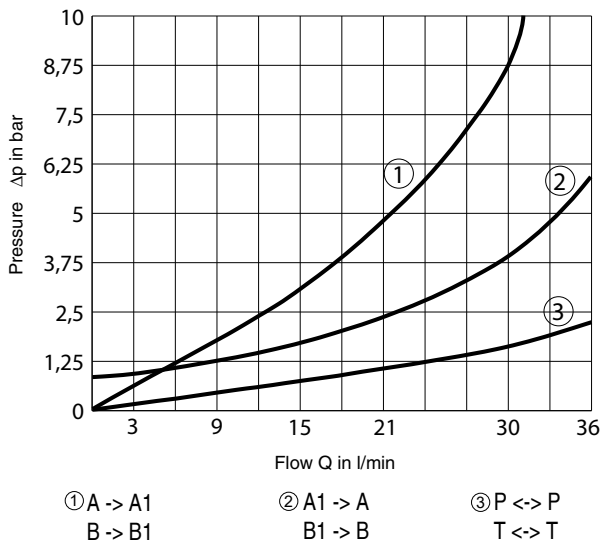

### 5 INSTALLATION DIMENSIONS (mm)

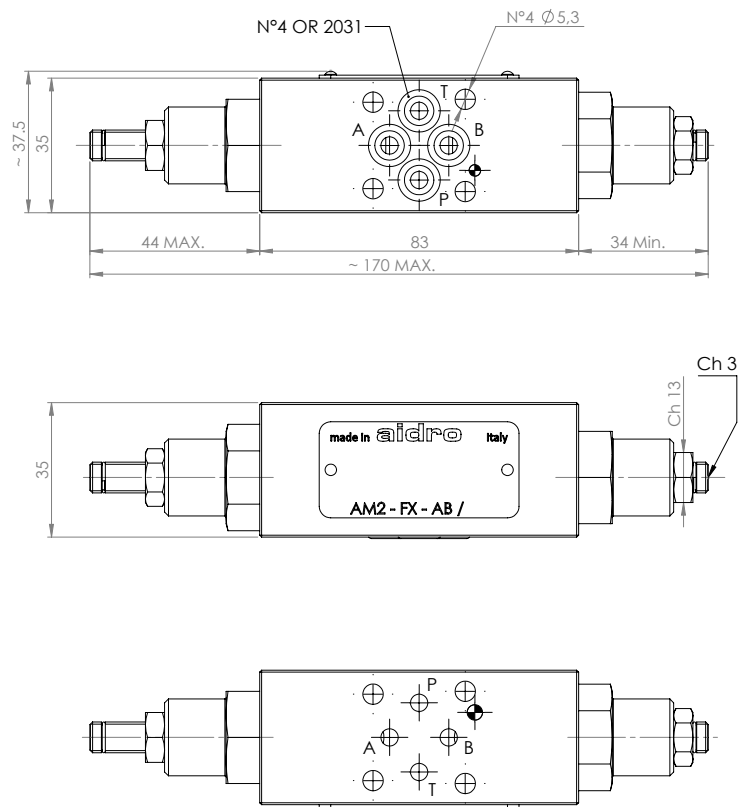

### 6 HYDRAULIC FLUIDS

Seals and materials used on standard valves AM2-\* are fully compatible with hydraulic fluids of mineral oil base, upgraded with antifoaming and antioxidizing agents. The hydraulic fluid must be kept clean and filtered to ISO 4406 class 19/17/14, or better, and used in a recommended viscosity range from 10 cSt to 60 cSt.

All stackable valves AM2-FX-\* conform with ISO and CETOP specifications for mounting surface dimensions. Valves height 35 mm. Leakage between valve and mounting surface is prevented by the positive compression on their seats of 4 seals of OR type. All valves have on their "mounting" surface a ø 4 mm cylindrical hole and are equipped on their "seals" surface by a ø 3 mm locating pin conform with ISO and CETOP norms. In case of necessity, the pin can be easily removed.

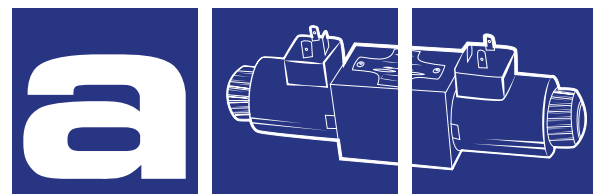

## STACKABLE CHECK VALVES

### AM2-CO-\*/10

30 l/min - 32 MPa (320 bar)

#### 1 DESCRIPTION

Direct operated check valve. All the internal part are made with high strenght steel and are machined with accuracy in order to assure the requested tightness. The controlled lines are A, B or AB. The standard surafce treatment of the body is phosphate coated. Plugs are zinc coated.

#### 2 ORDERING CODE

(1)	(2)	(3)	(4)	(5)	(6)
AM2	-	CO	-	-	/ 10

- (1) AM2: stackable valve CETOP 02- Pressure 32MPa (320bar)
- (2) CO: check valve, spring operated
- (3) Service lines where the controls operate:
  - AB : checks on A and B. Fluid flows A -> A1 and B -> B1 and cannot flow A1->A, B1->B, free on P and T
  - A : check on A: flow A1 -> A is blocked, free on B,P and T
  - B : check on B: flow B1 -> B is blocked, free on A,P and T
- (4) Check valve opening (cracking) pressure (Pm):
  - no designation: Pm approx 0,2MPa (2bar)
  - 4: Pm approx 0,4MPa (4bar)
- (5) Code reserved for special variants (materials, seals, surface treatments etc.).
- (6) Design number (progressive) of the valves

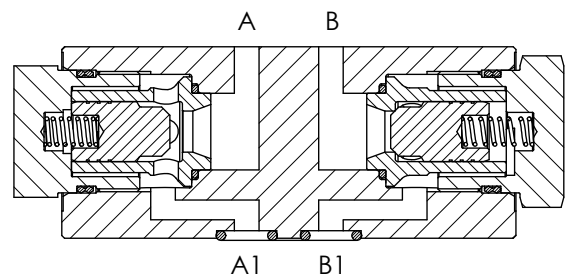
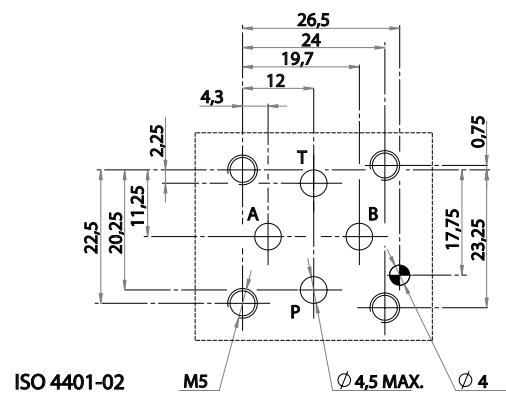
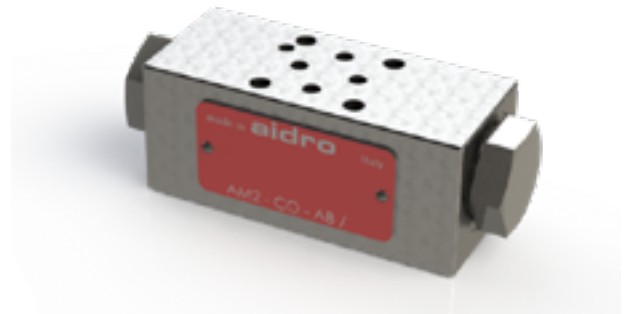

Fluid flows freely on P and T lines; on service lines A and/or B with controls, fluid flows from A -> A1 (and/or B -> B1) overcoming the force of spring acting on sleeve ; fluid flows from A1 -> A (and/or B1 -> B) through orifices of sleeve which is pushed against its seat; the throttling axis which is shifted by screwing it and locked by its nut , partially obstructs the control orifices, thus making the flow rate entirely dependent upon the available pressure drop.

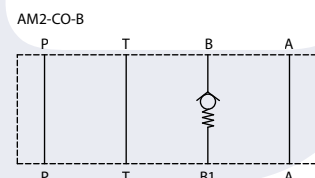
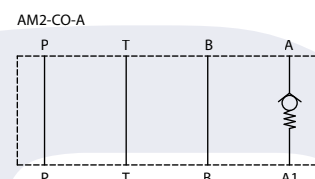
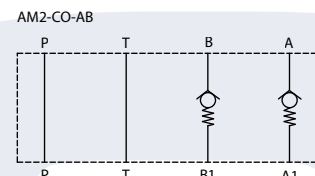

### 3 TECHNICAL DATA

Maximum rec. flow rate	30 l/min
Maximum nominal pressure	32 MPa (320 bar)
Pressure drops	see 5
Installation and dimensions	see 6
Mass	approx 0,75 kg

### 4 HYDRAULIC FLUIDS

Seals and materials used on standard valves AM2-\* are fully compatible with hydraulic fluids of mineral oil base, upgraded with antifoaming and antioxidantizing agents. The hydraulic fluid must be kept clean and filtered to ISO 4406 class 19/17/14, or better, and used in a recommended viscosity range from 10 cSt to 60 cSt.

### 5 TYPICAL DIAGRAMS

Typical  $\Delta p$ -Q curves for valves AM2-CO in standard configuration, with mineral oil at 36 cSt and at 50°C.

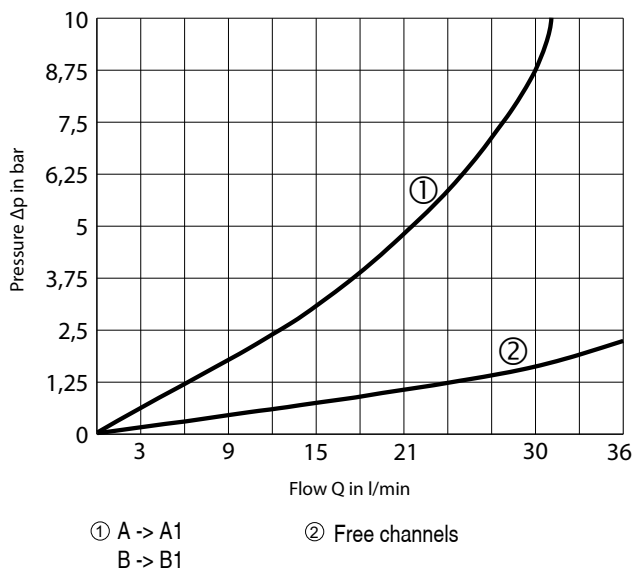

### 6 INSTALLATION DIMENSIONS (mm)

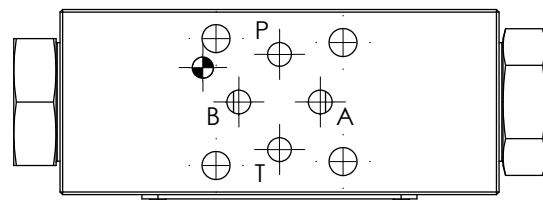
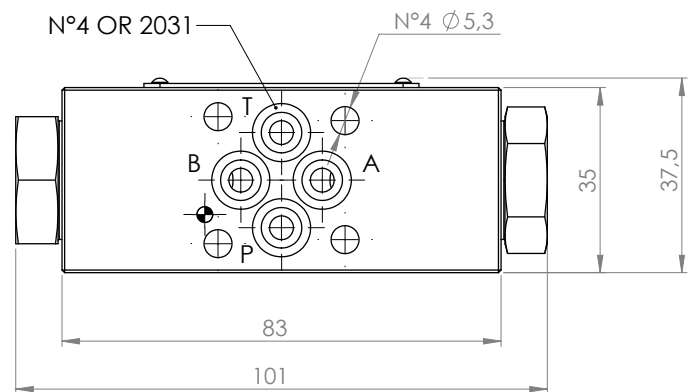

All stackable valves AM2-CO-\* conform with ISO and CETOP specifications for mounting surface dimensions (see also front page). Valves height 35 mm. Leakage between valve and mounting surface is prevented by the positive compression on their seats of 4 seals of OR type. All valves have on their "mounting" surface a  $\phi$  4 mm cylindrical hole and have on their "seals" surface a  $\phi$  3 mm cylindrical hole, conform with ISO and CETOP norms.

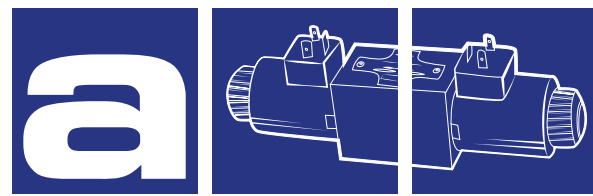

## STACKABLE CHECK VALVES

### AM2-CO-\*/20

30 l/min - 32 MPa (320 bar)

#### 1 DESCRIPTION

Direct operated check valve. All the internal part are made with high strenght steel and are machined with accuracy in order to assure the requested tightness. The controlled lines are P and T in different combinations. The standard surafce treatment of the body is phosphate coated.



#### 2 ORDERING CODE

(1)	(2)	(3)	(4)	(5)	(6)
AM2	-	CO	-	-	/ 20

- (1) AM2: stackable valve CETOP 02 - Pressure 32 MPa (320 bar)
- (2) CO: check valve, spring operated
- (3) Service lines where the controls operate:
  - T : checks on T: flow T1 -> T is blocked, free on A, B and P
  - P : check on P: flow P -> P1 is blocked, free on A, B and T
  - PT : check on P and T: P -> P1 and T1 -> T are blocked, free on A and B
- (4) Check valve opening (cracking) pressure (Pm):  
no designation (standard): Pm approx 0.2 MPa (2 bar)
- (5) Code reserved for special variants (materials, seals, surface treatments, etc.)
- (6) Design number (progressive) of the valves.

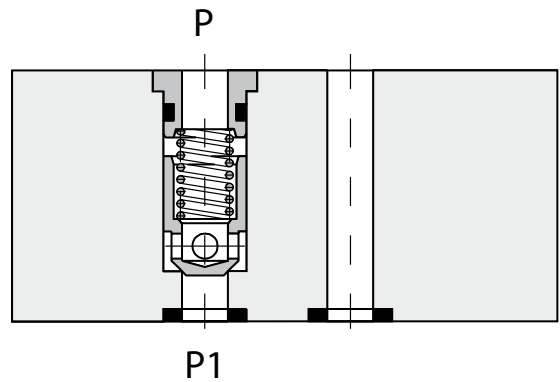
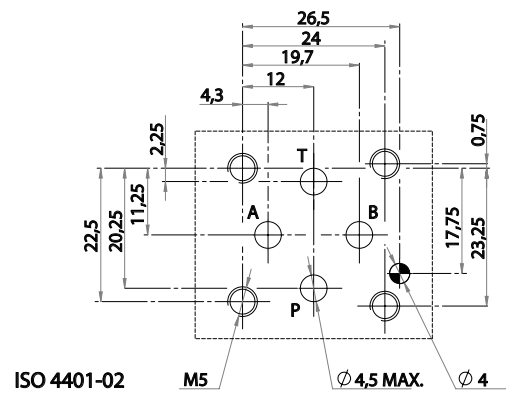

#### AM2-CO-T-\*/20

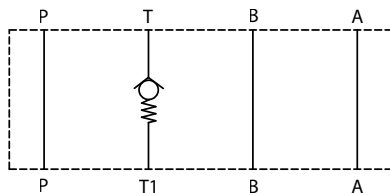

#### AM2-CO-P-\*/20

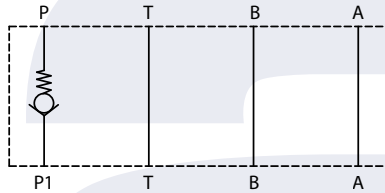

#### AM2-CO-PT-\*/20

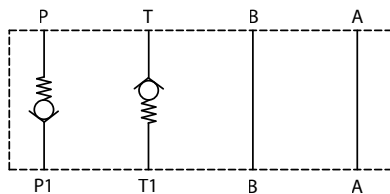



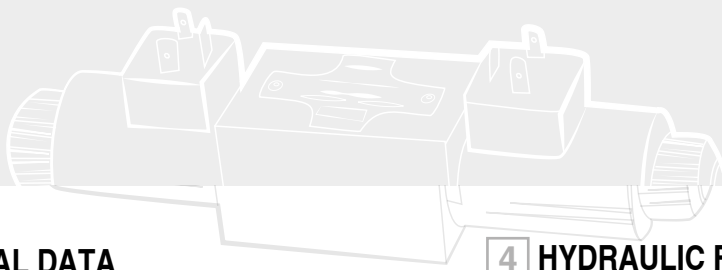

### 3 TECHNICAL DATA

Maximum rec. flow rate	30 l/min
Maximum nominal pressure	32 MPa (320 bar)
Pressure drops	see 5
Installation and dimensions	see 6
Mass	approx 0,5 kg

### 4 HYDRAULIC FLUIDS

Seals and materials used on standard valves AM2-\* are fully compatible with hydraulic fluids of mineral oil base, upgraded with antifoaming and antioxidantizing agents. The hydraulic fluid must be kept clean and filtered to ISO 4406 class 19/17/14, or better, and used in a recommended viscosity range from 10 cSt to 60 cSt.

### 5 TYPICAL DIAGRAMS

Typical  $\Delta p$ -Q curves for valves AM2-CO-/20 in standard configuration, with mineral oil at 36 cSt and at 50°C

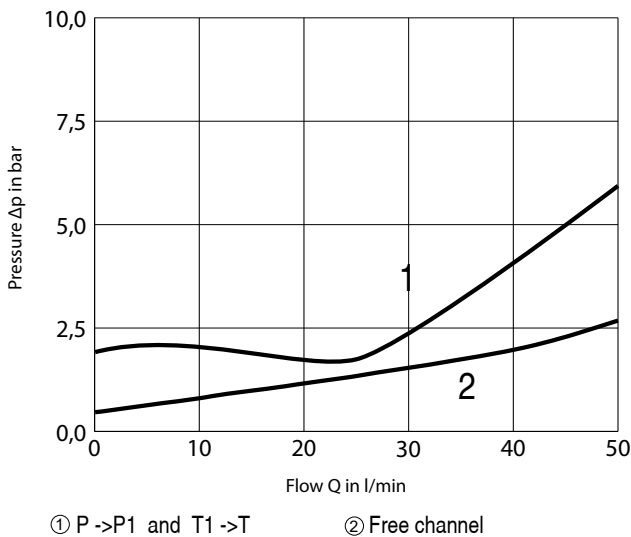

### 6 INSTALLATION DIMENSIONS (mm)

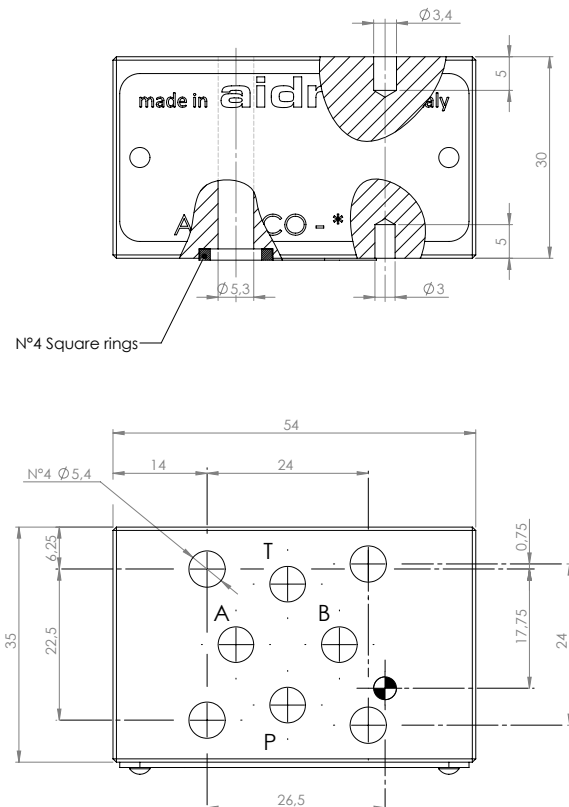

All stackable valves AM2-CO-\*/20 conform with ISO and CETOP specifications for mounting surface dimensions. Valves height 30 mm. Leakage between valve and mounting surface is prevented by the positive compression on their seats of 4 seals. All valves have on their "mounting" surface a  $\phi$  4 mm cylindrical hole and have on their "seals" surface a  $\phi$  3 mm cylindrical hole, conform with ISO and CETOP norms.

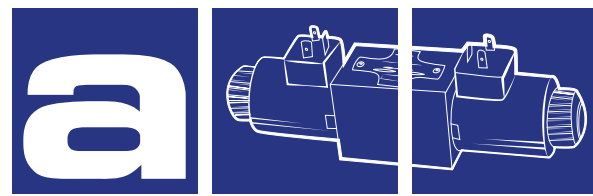

## STACKABLE PILOT OPERATED CHECK VALVES

### AM2-CP-\*

30 l/min - 32 MPa (320 bar)

#### 1 DESCRIPTION

Pilot operated check valve. All the internal part are made with high strenght steel and are machined with accuracy in order to assure the requested tightness. The controlled lines are A, B or AB. The standard surafce treatment of the body is phosphate coated. Plugs are zinc coated.



#### 2 ORDERING CODE

(1)	(2)	(3)	(4)	(5)	(6)	
AM2	-	CP	-	-	/	10

- (1) AM2: stackable valve CETOP 02 - Pressure 32 MPa (320 bar)
- (2) CP: check valve, pilot operated (hydraulically)
- (3) Service lines where the controls operate:
  - AB: pilot operated checks on A and B. Fluid flows A -> A1 and B -> B1 and flow A1 -> A (or B1 -> B) is permitted only when B (or A) is pressurized
  - A : pilot operated check on A; flow A1 -> A is permitted only when B is pressurized
  - B : pilot operated check on B; flow B1 -> B is permitted only when A is pressurized
- (4) Check valve opening (cracking) pressure (Pm) for free flow A -> A1 and B -> B1  
no designation: Pm approx 0.2 MPa (2 bar)  
4: Pm approx 0.4 MPa (4 bar)
- (5) Code reserved for special variants (materials, seals, surface treatments, etc.)
- (6) Design number (progressive) of the valves.

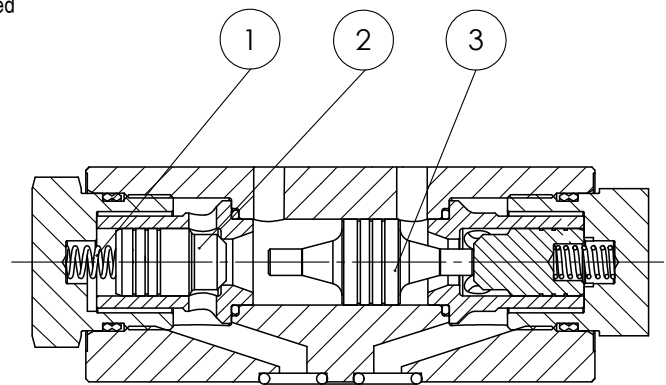
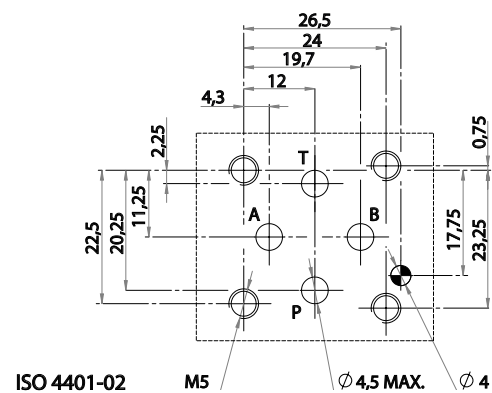

#### AM2-CP-AB

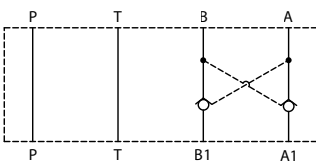

#### AM2-CP-B

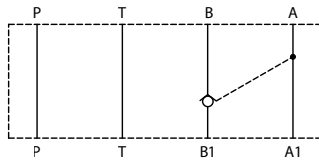

#### AM2-CP-A

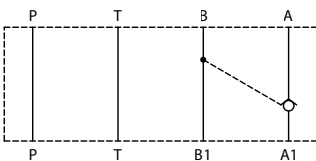

Fluid flows freely on P and T lines; on service lines A and/or B with p.o. check, fluid flows from A -> A1 (and/or B -> B1) overcoming the force of spring 1 acting on poppet 2, and fluid is blocked from A1 -> A (and/or B1 -> B). When, by switching the solenoid operated 4-way directional valve, pressure is made available at, for instance, port B fluid flows B -> B1 and the pilot piston 3, shifting from its central position, forces poppet 2, on service line A, to open and permit flow A1 -> A.

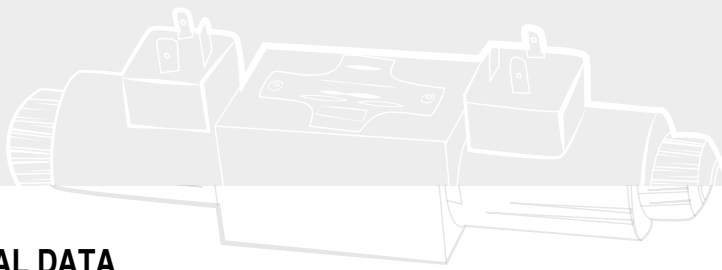

### 3 TECHNICAL DATA

Maximum rec. flow rate	30 l/min	<b>Piloting pressure:</b>  To shift the pilot piston and to open the check in A the piloting pressure must be at B: $P_p = P_b = \frac{P_{a1} + P_m - P_a}{3,5} + P_a$  where: Pp = piloting pressure; Pb = pressure in B; Pa = pressure in A; Pa1 = pressure in A1; Pm = check valve opening pressure (spring)  or: to open the check in B:  $P_p = P_a = \frac{P_{b1} + P_m - P_b}{3,5} + P_b$
Maximum nominal pressure	32 MPa (320 bar)	
Pressure drops	see 4	
Pilot area ratio piston/check valve	approx 3,5	
Installation and dimensions	see 5	
Mass	approx 0,5 kg	

### 4 TYPICAL DIAGRAMS

Typical  $\Delta p$ -Q curves for valves AM2 -CP-AB in standard configuration, with mineral oil at 36 cSt and at 50°C

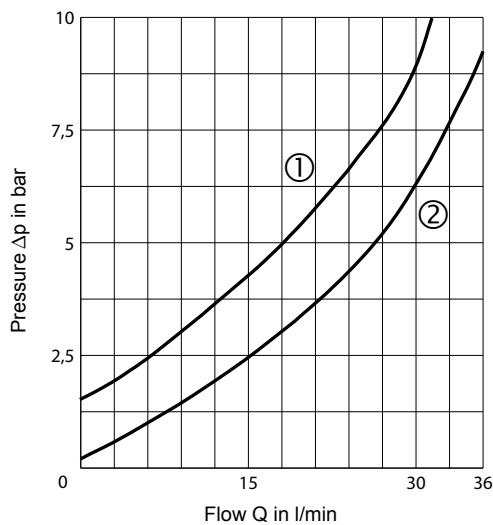

- ① A → A1  
B → B1
- ② A1 → A  
B1 → B

### 6 HYDRAULIC FLUIDS

Seals and materials used on standard valves AM2-\* are fully compatible with hydraulic fluids of mineral oil base, upgraded with antifoaming and antioxidizing agents. The hydraulic fluid must be kept clean and filtered to ISO 4406 class 19/17/14, or better, and used in a recommended viscosity range from 10 cSt to 60 cSt.

### 5 INSTALLATION DIMENSIONS (mm)

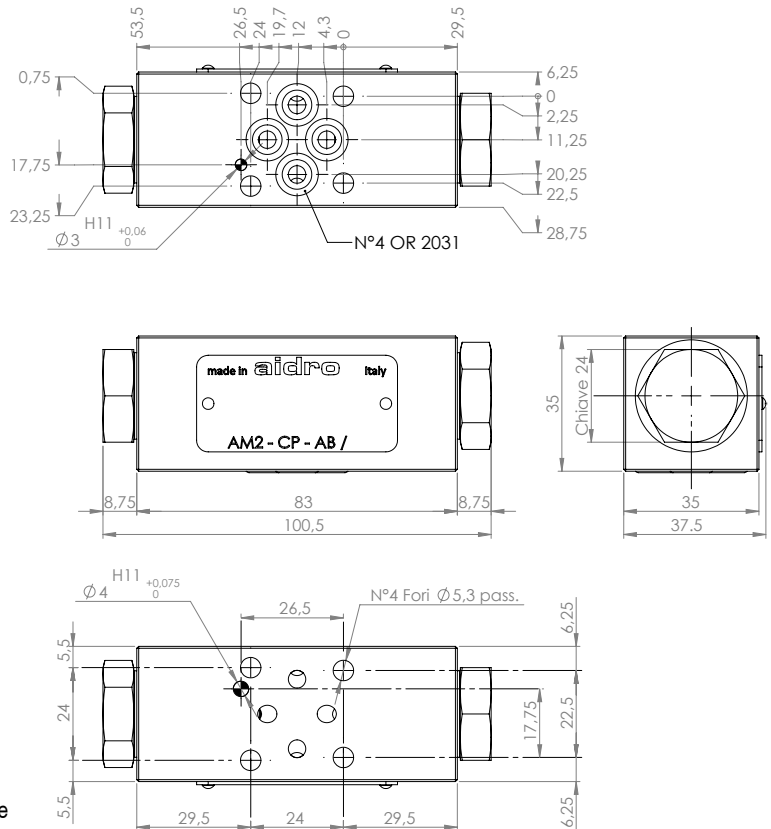

All stackable valves AM2-CP-\* conform with ISO and CETOP specifications for mounting surface dimensions (see also front page). Valves height 35 mm. Leakage between valve and mounting surface is prevented by the positive compression on their seats of 4 seals of OR type. All valves have on their "mounting" surface a  $\varnothing 4$  mm cylindrical hole and have on their "seals" surface a  $\varnothing 3$  mm cylindrical hole, conform with ISO and CETOP norms.

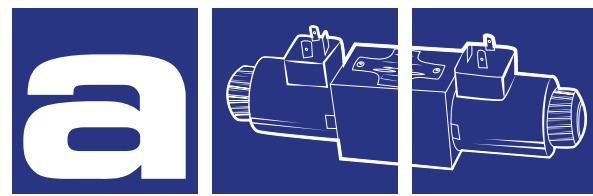

## STACKABLE PRESSURE RELIEF VALVES

### AM2-MO-\*

20 l/min - 32 MPa (320 bar)

#### 1 DESCRIPTION

Stackable pressure relief valve direct operated. The valve is made with a steel body combined with a pressure relief cartridge valve with an anti vibration system.

The body of the valve is phosphate coated. The cartridge valve is zinc coated. The pressure can be set in different pressure ranges.



#### 2 ORDERING CODE

(1)	(2)	(3)	(4)	(5)	(6)	(7)
AM2	- MO	-	/	-	-	/ 10

(1) AM2 : stackable valve CETOP 02 - Pressure 32 MPa (320 bar)

(2) MO : pressure relief, direct acting

(3) Service lines where the controls operate:

P : relief on P and discharge to T

B : relief on B and discharge to T

BA: independent relief on B and on A and discharge to T

(4) Pressure adjustment ranges:

10: from 6,3 MPa to 12,5 MPa (from 63 to 125 bar)

20: from 8 MPa to 21 MPa (from 80 to 210 bar)

32: from 12,5 MPa to 35 MPa (from 125 to 350 bar)

(5) Pressure adjustment range for relief on A (only for models AM2-MO-BA)

(6) Code reserved for special variants (materials, seals, surface treatments, etc.)

(7) Design number (progressive) of the valves.

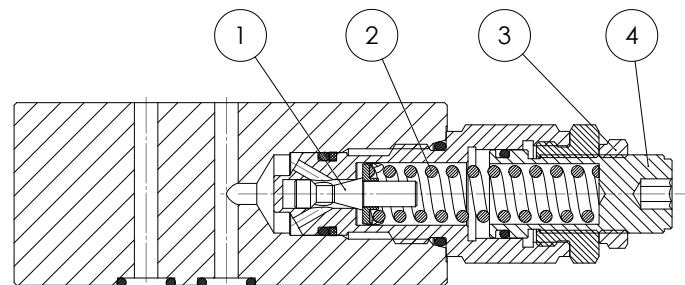
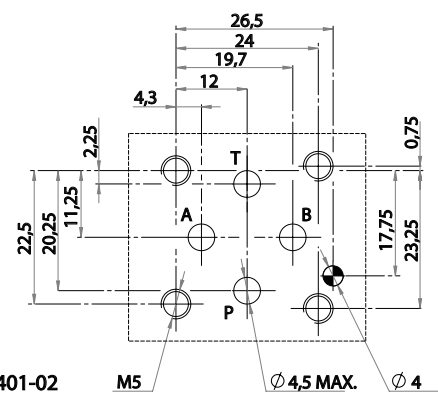

#### AM2-MO-P

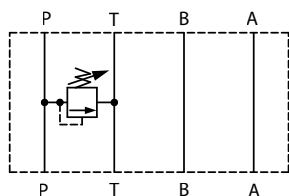

#### AM2-MO-BA

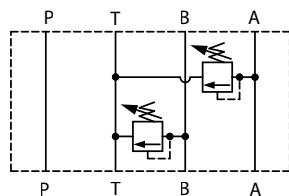

#### AM2-MO-B

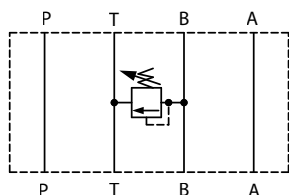

Fluid flows freely on A, B, P and T lines; when on service line, protected by the relief valve, the pressure exceeds the settled value, the piston 1 is pushed by axial hydraulic force, overcomes the force of spring 2, and shifts in its cylindrical seat and opens to the pressurized fluid annular passage to T, thus keeping the pressure level at the requested value.

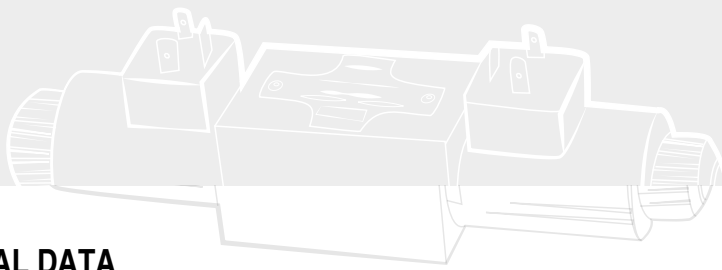

### 3 TECHNICAL DATA

Maximum rec. flow rate	20 l/min	Adjustment of the relief pressure:  Relief pressure is reached when the axial hydraulic forces on piston equal the force of spring; the value of the relief pressure can be therefore changed, within the limits of the chosen adjustment range, by changing the compression of spring. To increase the relief pressure, turn clock wise the adjustment screw, after having unlocked its nut.  For each pressure adjustment range, the pressure gradient is approx: 10 : 1,6 MPa/mm (16 bar/turn) 20 : 2,6 MPa/mm (26 bar/turn) 32 : 5 MPa/mm (50 bar/turn)  When the required level of pressure is reached, lock the nut.
Maximum nominal pressure	32 MPa (320 bar)	
Pressure relief curves	see 4	
Installation and dimensions	see 5	
Masses:		
AM2-MO-P or -B	approx 0,85 kg	
AM2-MO-BA	approx 1 kg	

### 4 TYPICAL DIAGRAMS

Typical curves for valves AM2-MO-\* in standard configuration, with mineral oil at 36 cSt and at 50°C.

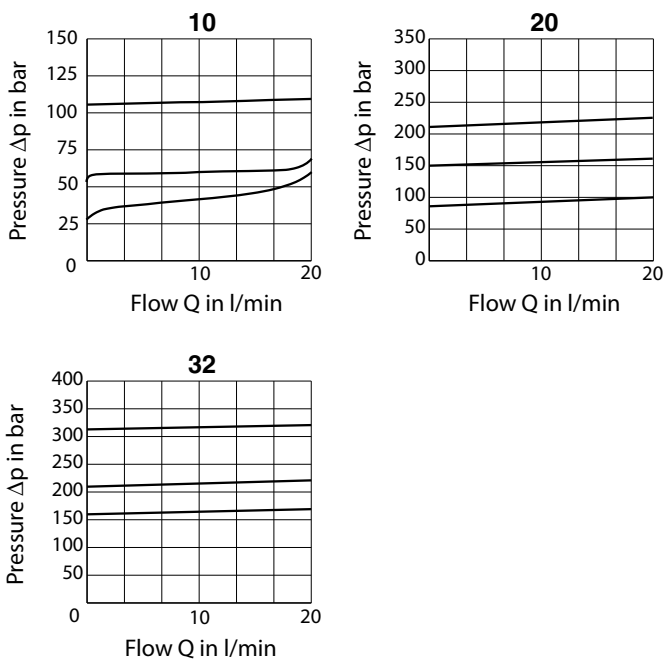

### 5 INSTALLATION DIMENSIONS (mm)

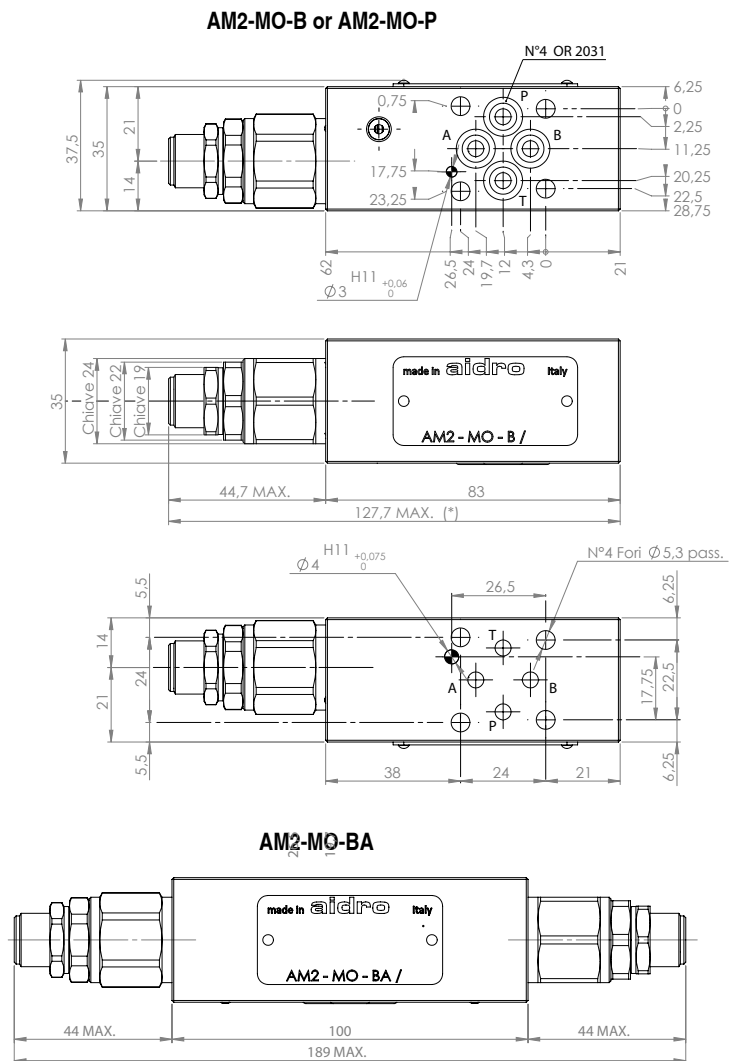

### 6 HYDRAULIC FLUIDS

Seals and materials used on standard valves AM2-\* are fully compatible with hydraulic fluids of mineral oil base, upgraded with antifoaming and antioxidantizing agents. The hydraulic fluid must be kept clean and filtered to ISO 4406 class 19/17/14, or better, and used in a recommended viscosity range from 10 cSt to 60 cSt.

All stackable valves AM2-MO-\* conform with ISO and CETOP specifications for mounting surface dimensions (see also front page). Valves height 35 mm. Leakage between valve and mounting surface is prevented by the positive compression on their seats of 4 seals of OR type. All valves have on their "mounting" surface a  $\phi$  4 mm cylindrical hole and have on their "seals" surface a  $\phi$  3 mm cylindrical hole, conform with ISO and CETOP norms.

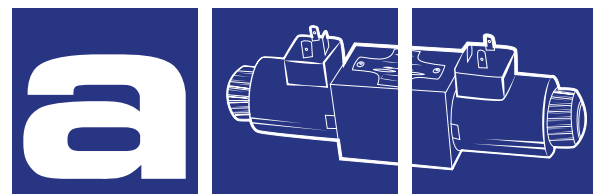

## MODULAR VALVES PRESSURE REDUCING

### AM2-RO-\*

30 l/min - 32 MPa (320 bar)

#### 1 DESCRIPTION

Stackable pressure reducing valve direct operated. The valve is made with a steel body combined with a pressure relief cartridge valve. The body of the valve is phosphate coated. The cartridge valve is zinc coated. The pressure can be set in different pressure ranges.



#### 2 ORDERING CODE

(1)	(2)	(3)	(4)	(5)	(6)		
AM2	-	RO	-	/	-	/	20

(1) AM2 : stackable valve CETOP 02 - Pressure 32 MPa (320 bar)

(2) RO : pressure reducing, direct operated- 3 way valve

(3) Service lines where the controls operate:

P : control on P with 3<sup>rd</sup> way and drain to T line

AC: control on A with check valve

B : control on P with pressure reduced on B

(4) Controlled pressure adjustment ranges:

2,5: from 0,4 MPa to 3,2 MPa (from 4 to 32 bar)

6,3: from 0,5 MPa to 8 MPa (from 5 to 80 bar)

16: from 1 MPa to 20 MPa (from 10 to 200 bar)

20: from 2,5 MPa to 25 MPa (from 25 to 250 bar)

(5) Code reserved for special variants (materials, seals, surface treatments, etc.)

V= adjustment hand knob

(6) Design number (progressive) of the valves.

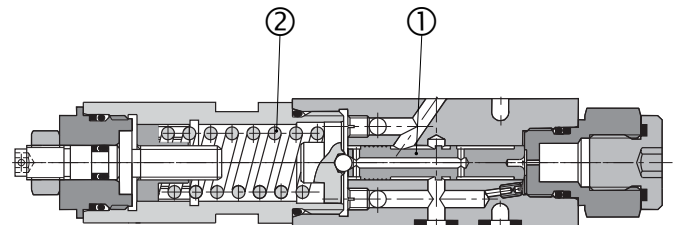
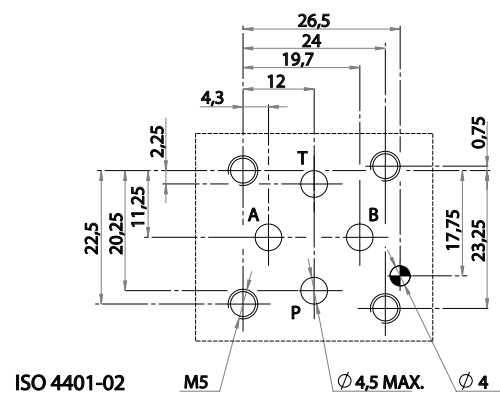

#### AM2-RO-P

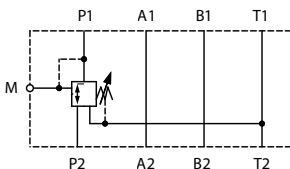

#### AM2-RO-B

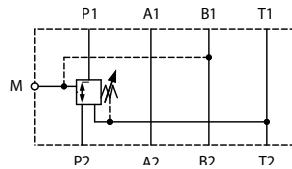

#### AM2-RO-AC

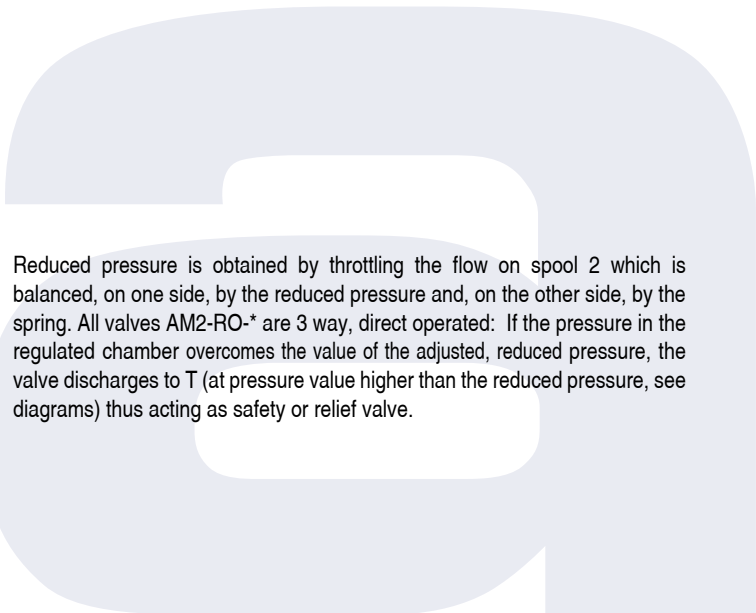
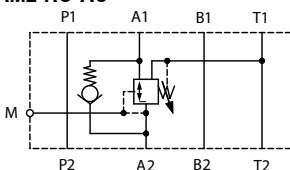

Reduced pressure is obtained by throttling the flow on spool 2 which is balanced, on one side, by the reduced pressure and, on the other side, by the spring. All valves AM2-RO-\* are 3 way, direct operated: If the pressure in the regulated chamber overcomes the value of the adjusted, reduced pressure, the valve discharges to T (at pressure value higher than the reduced pressure, see diagrams) thus acting as safety or relief valve.

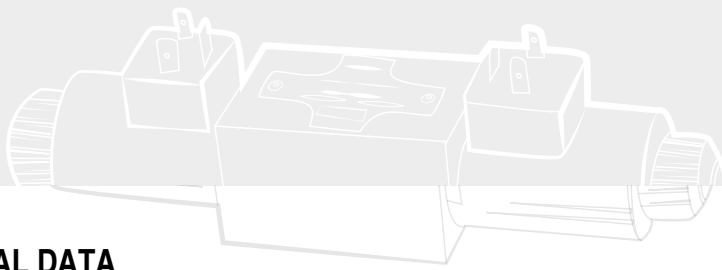

### 3 TECHNICAL DATA

Maximum rec. flow rate on free lines	30 l/min	Adjustment of the pressure: The value of the reduced pressure, is changing the compression of spring. To increase the value of the reduced pressure, unlock nut ch. 13 and turn clockwise the screw with outside hex 4.
on controlled lines	20 l/min	
Maximum nominal pressure	32 MPa (320 bar)	
Maximum pressure on T	10 MPa (100 bar)	
Pressure curves	see 4	Valve reducing pressure on A or B lines can be: - indirect (type AM2-RO-B) they act on P line, receive reduced pressure pilot signal from B line that is controlled; (eventual pressurized reverse flow is directed to T by 3 <sup>a</sup> way). - with integral check valve (type AM2-RO-AC) they act on A line and they allow free reverse flow to port A of the solenoid valve. (see P).
Installation and dimensions	see 5	
Masses:		
AM2-RO-P or -B	approx 0,6 kg	
AM2-RO-AC	approx 0,8 kg	

### 4 TYPICAL DIAGRAMS

Typical curves for valves AM2-RO in standard configuration, with mineral oil at 36 cSt and at 50°C.

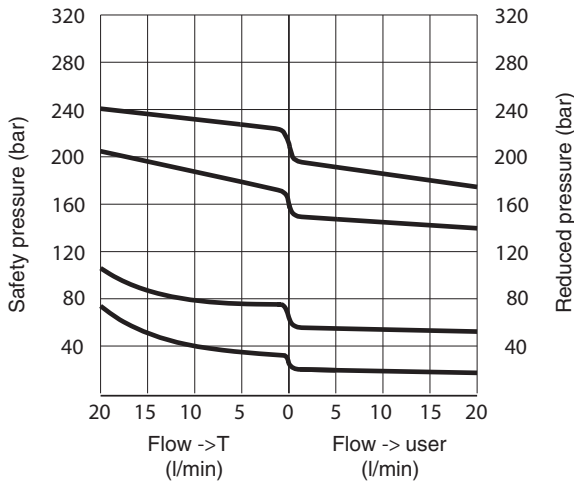

### 5 INSTALLATION DIMENSIONS (mm)

AM2-RO-AC

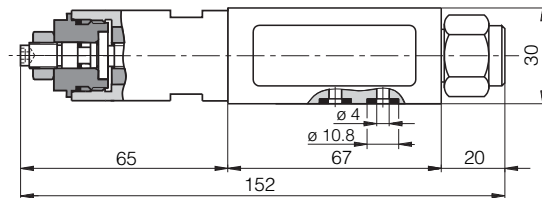

AM2-RO-P  
AM2-RO-B

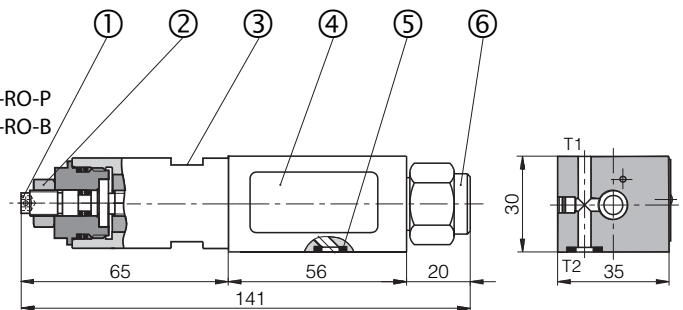

### 6 HYDRAULIC FLUIDS

Seals and materials used on standard valves AM2-RO\* are fully compatible with hydraulic fluids of mineral oil base, upgraded with antifoaming and antioxidantizing agents. The hydraulic fluid must be kept clean and filtered to ISO 4406 class 19/17/14, or better, and used in a recommended viscosity range from 10 cSt to 60 cSt.

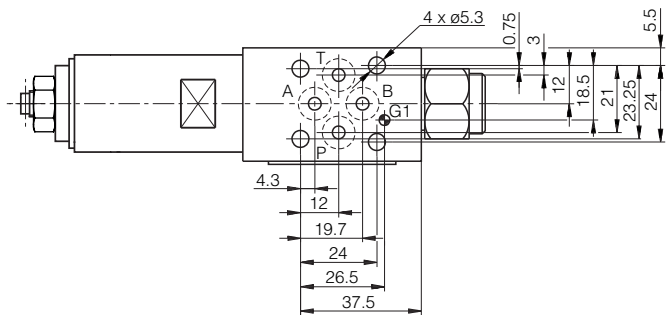

- ① Pressure adjustment element, screw with outside ch. 4
- ② Locknut ch. 13
- ③ Wrench flats ch. 24
- ④ Name plate
- ⑤ N°4 square ring 7.65x1.68 supplied with each valve
- ⑥ Plug for pressure gauge connection, thread G1/4"

All stackable valves AM2-\* conform with ISO and CETOP specifications for mounting surface dimensions. Valves height 30 mm. Leakage between valve and mounting surface is prevented by the positive compression on their seats of 4 seals of OR type.





# SUMMARY



## **3** CETOP 03

DIRECTIONAL CONTROL VALVES SOLENOID OPERATED

**HD3-ES-\*/10** 0001

---

DIRECTIONAL CONTROL VALVES SOLENOID OPERATED

**HD3 -ES-\*/20** 0006

---

DIRECTIONAL CONTROL VALVES SOLENOID OPERATED

**HD33-EF-\*** 0010

---

DIRECTIONAL CONTROL VALVES LEVER OPERATED

**HD3-LO-\*** 0013

---

FLOW RESTRICTOR VALVES

**AM3-FO-\*** 0015

---

FLOW CONTROL VALVES

**AM3-FC-\*** 0017

---

FLOW CONTROL VALVES

**AM3-FX-\*** 0019

---

FLOW CONTROL VALVES

**AM3-CO-\*** 0021

---

FLOW CONTROL VALVES

**AM3-CO-\*/25** 0023

---

PILOT OPERATED CHECK VALVES

**AM3-CP-\*** 0025

---

PRESSURE RELIEF VALVES

**AM3-MO-\*** 0027

---

PRESSURE RELIEF VALVES

**AM3-M\*-EV\*** 0029

---

**aidro**  
hydraulics



## **3 CETOP 03**

### **PRESSURE REDUCING VALVES**

**AM3-MP-\*** 0031

---

### **DIRECT ACTING, PRESSURE REDUCING VALVES ON B LINE**

**AM3-RO\*** 0033

---

### **PRESSURE REDUCING MODULAR VALVES**

**AM3-RO-BC/6,3** 0035

---

### **MODULAR VALVES 3-WAY PRESSURE COMPENSATOR WITH LOAD SENSING**

**AM3-RP-\*** 0037

---

### **2-WAY PRESSURE COMPENSATOR MODULAR VALVES**

**AM3-LS-P3** 0039

---

### **PRESSURE COMPENSATED FLOW CONTROL VALVES**

**AM3-PC-\*** 0041

---

### **PRESSURE COMPENSATED FLOW CONTROL VALVES**

**AM3-Q3-P** 0043

---

### **PRESSURE COMPENSATED FLOW CONTROL VALVES**

**AM3-Q\*-A** 0045

---

**QVC-06** 0047

---

**SANDWICH VALVES WITH 3/4" 16 UNF 2-WAY CARTRIDGE VALVES** 0049

---

### **SAE STANDARD 2-WAY CAVITY 3/4 16" UNF ON P LINE**

**AM3-\*-P/34** 0050

---

**AM3-\*-C** 0051

---

### **STACKABLE VALVE CHECK VALVE ON p LINE**

**AM3-\*-X** 0053

---



## **3** CETOP 03

STACKABLE VALVE ADJUSTABLE FLOW CONTROL

**AM3-CO-P/34** 0055

---

STACKABLE VALVE PRESSURE COMPENSATED, FIXED CONTROL VALVES

**AM3-FO-P/34** 0057

---

STACKABLE VALVE PRESSURE COMPENSATED, adjustable flow CONTROL VALVES

**AM3-Q\*-P/34** 0059

---

STACKABLE VALVE lock, solenoid operated control valve on P line

**AM3-EVD-P/34-(024C)** 0061

---

MONOBLOCK WITH MULTIPLE SECTIONS ISO 03

**MR-3-\*G** 0063

---

MONOBLOCK WITH MULTIPLE SECTIONS ISO 03

**MRK-3-\* G** 0065

---

MONOBLOCK WITH MULTIPLE SECTIONS ISO 03

**MRSK-3-38G** 0067

---

ISO 03 PLATE

**BM3-G** 0068

---

**aidro**  
hydraulics



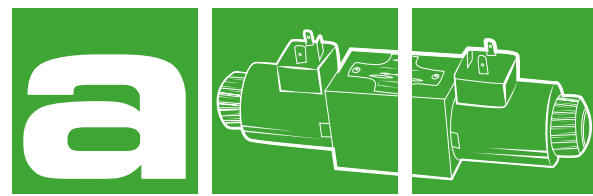

## DIRECTIONAL CONTROL VALVES SOLENOID OPERATED

### HD3-ES-\*/10

80 l/min - 35 MPa (350 bar)

#### 1 DESCRIPTION

Valves HD3-ES are directional control valve with subplate mounting interface acc. to ISO 4401, DIN 24340 (CETOP 03).

The design of the body is a quality five chamber casting.

The valve is available with interchangeable metallic DC solenoids, also for AC power supply using a built-in rectifier bridge inside the coil.

In the standard version, the valve housing is phosphated for 240 h salt spray protection acc. to ISO 9227. Enhanced surface protection for mobile sector available (ISO 9227, 520 h salt spray).

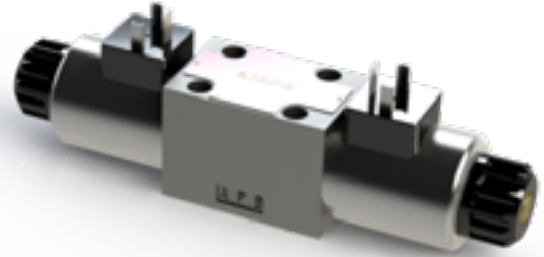

#### 2 ORDERING CODE

(1)	(2)	(3)	(4)	(5)	(6)	(7)
HD3	-	ES	-	-	-	/ 10

(1) HD3: 4-way directional control valve CETOP 03

(2) ES: Electrically controlled

(3) Spool type (see 4):

-number is the main spool type

-letter is the solenoid or spring arrangement:

C : 2 solenoids, spool is spring centered (3 position)

LL : 1 solenoid, spool is spring offset (2 position)

ML : 1 solenoid, spool is spring centered (2 position)

N : 2 solenoids, spool is detented see 13 (2 position)

(4) Code reserved for option and variants:

S-\*\*: calibrated orifice on P port, see 11

K : water proof caps on emergency pin, see 10

T : soft shifting device, see 12

Z\* : anti corrosion coating (variants), see 14

Sa, Sb: proximity sensors, see 15

(5) Electric voltage and solenoid coils: see 8

0000: no coils

012C: coils for V12DC

024C: coils for V24DC

048C: coils for V48DC

024A: coils for V24/50AC

115A: coils for V110/50- V 115/60AC

230A: coils for V220/50- V 230/60AC

(6) Coil connection (see 16):

no designation: DIN 43650-A ISO 4400

AMP: Amp Junior Timer- vertical configuration

AMPX: Amp Junior Timer- axial configuration

D: Deutsch

(7) Design number (progressive) of the valves

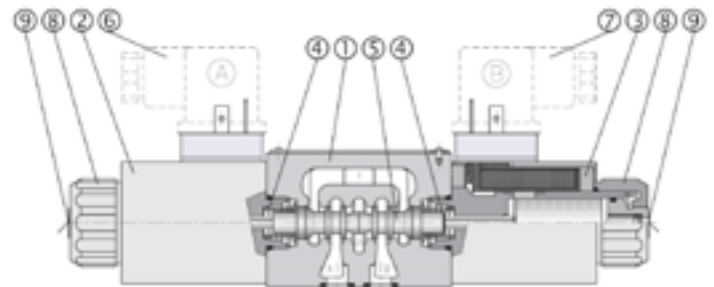
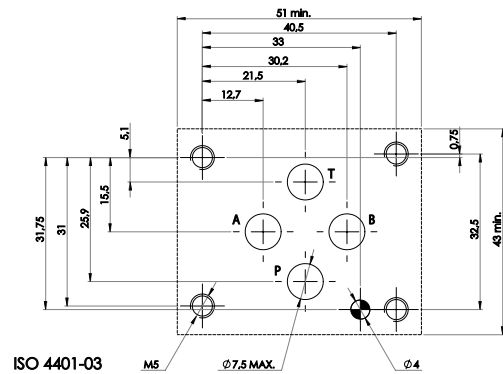

The spool 5 shifts into the valve body 1 subject to the action of springs 4 and solenoids 2. Spool 5, depending from its shape and its position in the valve body, opens and/ or closes passages between P, A, B and T ports, thus controlling the direction of the hydraulic flow.

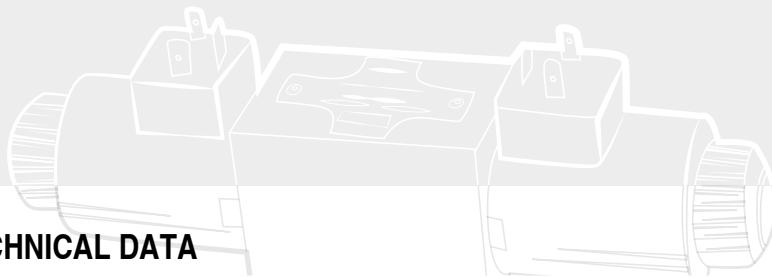

### 3 TECHNICAL DATA

Nominal flow	60 l/min	<b>Electric characteristics:</b>  Valve type HD3-ES-* are operated by solenoid that are energized : Directly from a D.C. voltage supply: V 12 DC = 012 C      V 24 DC = 024C By the use of coils that incorporate a full wave bridge rectifier, from A.C. voltage supply: V 110/50 - V 115/60 = 115A V 220/50 - V 230/60 = 230A Other available voltages are : 014C ; 048C ; 060C ; 102C ; 205C ; and V24/50 = 024A  All connectors must conform to ISO 4400 (DIN 43650) and electric circuitry must be able to carry the following rated current values : V 12 DC = 2,4A      V 115/50 = 0,26A V 24 DC = 1,2A      V 230/50 = 0,14A  Coils with 2 electric pins, conforming with AMP connectors or Deutsch connectors, are only available for DC supply (example of code: B03.012C AMPX or B03.012C D). Permissible supply voltage variation : ± 10 %
Maximum rec. flow rate	80 l/min	
Maximum nominal pressure (P, A, B)	35 MPa (350 bar)	
Maximum pressure at T port	21 MPa (210 bar)	
Pressure drops	see [5]	
Protection to DIN 40050	IP 65	
Duty cycle	100%	
Installation and dimensions	see [6]	
Mass	2,1/1,6 kg	

### 4 SPOOL IDENTIFICATION AND INTERMEDIATE POSITION TRANSITORIES

0C		0LL	
1C		1LL	
3C		1LLb	
4C		2LL	
55C		0ML	
7C		1ML	
8C		3ML	
1N		4ML	
2N		8ML	
19C		18ML	
42C		13ML	
56C		56ML	
38C		56MLb	

## 5 TYPICAL DIAGRAMS

Typical  $\Delta p$ -Q curves for valves HD3-ES-\* in standard configuration, with mineral oil at 32 mm<sup>2</sup>/s and T=40°C

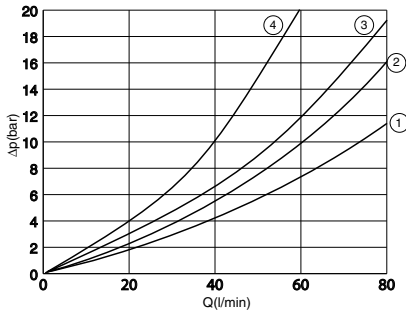

Spool	P-A	P-B	A-T	B-T	P-T
1C	1	1	2	2	
4C	3	3	4	4	1
0C	1	1	2	2	1
3C	1	1	2	2	
1LL	1	1	2	2	
1LLb	1	1	2	2	
1ML		1	2		
4ML	4		4		2
0ML		1	2		1
3ML	1		2		

## 7 HYDRAULIC LIMIT OF USE

$\Delta p$ -Q characteristics limits for safe of HD3-ES-\* solenoid operated valves. Measured at  $v = 32\text{mm}^2/\text{s}$  and  $T = 40^\circ\text{C}$

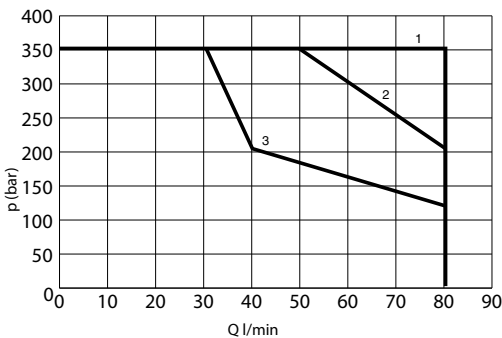

1C	1
4C	3
0C	2
3C	2
1LL	1
3ML	2
4ML	3
1ML	1
0ML	2
1MLb	1
1LLb	1
4MLb	3
0MLb	2
3MLb	2

## 8 SOLENOID

Solenoid valves can be supplied without electric coils, as HD3-ES-\*\*\*-0000. Coils are supplied separately; standard, 3 electric pins, coils are : - B03.012C ; B03.024C ; B03.115A ; B03.230A Connections to the electric supply is made by standard 3-PIN connectors, according to ISO 4400 (DIN 43650). Connectors can be with different cable exit size (PG9, PG11) and beside of the plain connecting function they may incorporate various features like: Signal led, Voltage surge suppressor, etc. (see 18)

## 6 INSTALLATION DIMENSIONS (mm)

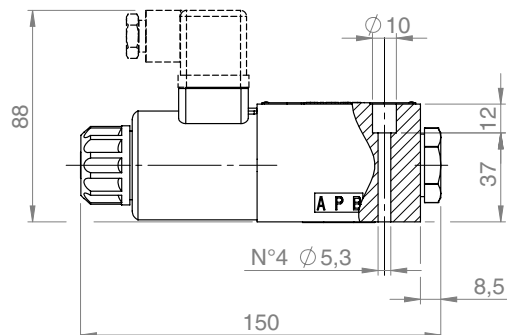
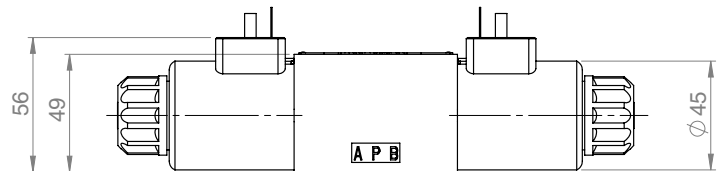
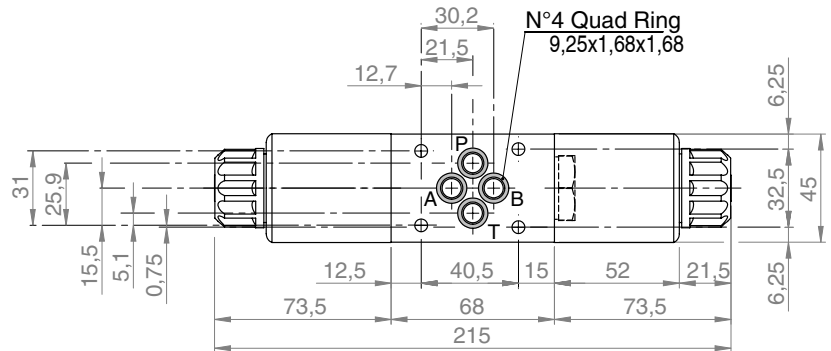

All valves HD3-\* conform with ISO and CETOP specifications for mounting surface dimensions (see 9) and for valves height. When assembled to its mounting plate valve HD3-\* must be fastened with 4 bolts M5x45 (or M5x\*\* according to the number of modules) tightened at 8 Nm torque. Leakage between valve and mounting surface is prevented by the positive compression on their seats of 4 seals of Quad Ring type 9,25x1,68x1,68.

## 9 HYDRAULIC FLUID

Seals and materials used on standard valves HD3-\* are fully compatible with hydraulics fluids of mineral base, upgraded with antifoaming and anti oxidizing agents. The hydraulic fluid must be kept clean and filtered to ISO 4406 class 19/17/14, or better, and used in a recommended viscosity range from 10 cSt to 60 cSt.

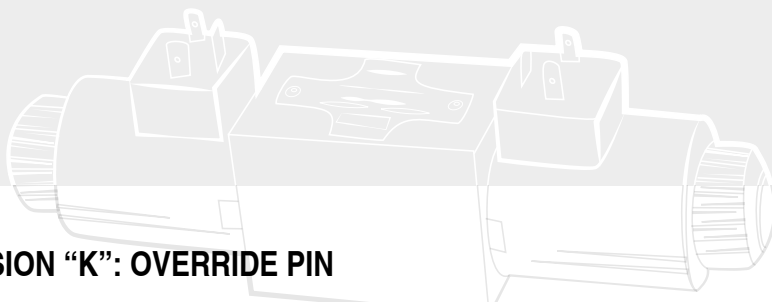

## 10 VERSION "K": OVERRIDE PIN

Solenoid valves according to "K" version have extended emergency actuator pins protruding from the solenoid shape, that permit a quick and easy "hand operation" of the valves, without the need of any tool. The actuator pin and the end of the solenoid are protected by a flexible rubber cap that makes easy operation and protects from moisture and water splashes

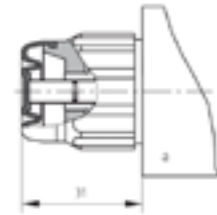

## 11 VERSION "S\*"; CALIBRATED ORIFICE ON P PORT

Option "S\*" is represented by an element suitably shaped to be inserted on P port of the solenoid valve, having a calibrated orifice (of various sizes) able to restrict, depending on the  $\Delta P$  value, the flow rate entering the solenoid valve.

Those elements have the following orifice diameters :

- 3S-00 -> D = 0 mm
- 3S-10 -> D = 1,0 mm
- 3S-15 -> D = 1,5 mm
- 3S-20 -> D = 2,0 mm
- 3S-25 -> D = 2,5 mm

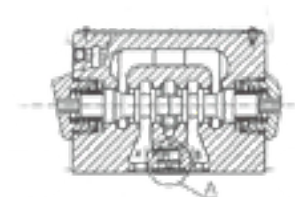
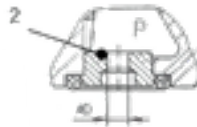

and are kept sealed on the P port of the valve by an OR of 9,25x1,78 mm sizes (example OR 110-2037)

## 12 VERSION "T": SOFT SHIFTING

Solenoid valves with "soft shifting" devices are 2 or 3 positions valves controlled by solenoids which incorporate calibrated orifices in the armature plungers. The hydraulic controls on the shifting speed of the plunger, and therefore of the spool in the valve's body, permit progressive transitories, thus reducing or eliminating water hammer effects in the circuit. Typically the shifting time of a "T" version solenoid valve is, when energized, in the order of 300-500 ms (versus 30-50 ms of a standard valve) provided that the armature plunger properly works in the hydraulic fluid. The appropriate conditions are given by assuring a minimum counter pressure on T line and by bleeding the air from the solenoid acting on purge's valve 1, which is accessible after removing the rubber boot 2 from the solenoid retaining nut 3.

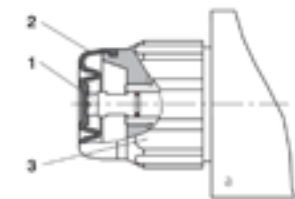

## 13 VERSION "N": MECHANICAL DETENT ON SPOOL

Solenoids valves with detent typically are 2 position, 2 solenoid, no-spring valves where the spool is kept at the extreme ends of its stroke by a mechanical device. This permits that solenoids are energized by short time current pulses and the spool remains at its position regardless of forces due to hydrodynamics or gravitational/ inertial effects (vibrations).

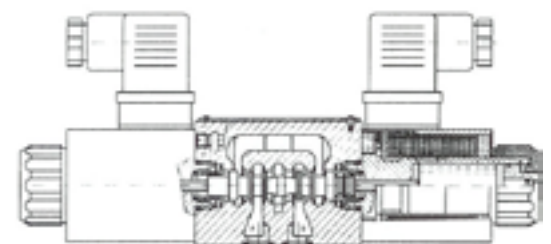

## 14 VERSION "Z": ANTICORROSION OPTION

On HD3-ES-\* standard valves the body is phosphate coated, the solenoid tubes are not treated and coils mantel and irons are zinc trivalent plated. To increase the resistance to corrosive agents different variants are available :

Example of ZK painted : HD3-ES-3C-ZK-024C/10

ZT: Body, solenoid tubes and coils irons are zinc trivalent plated

ZL: Body is coated with special TEMADUR 20 zinc painting

Solenoids have 8-12  $\mu\text{m}$  zinc plating

ZK: Body is coated with special TEMADUR 20 zinc painting

Solenoids tube and coils irons are "zinc-nickel" plated



## 15 VERSION "Sa and Sb": POSITION SENSOR

Solenoid valves with spool position sensors are equipped with a proximity sensor able to transform the spool position into an electric signal. It can be used with directional control valves with one or two solenoids. It's possible to have the two different versions, normally open and normally closed sensor. This option is mandatory in "safe" application, where an electric signal of positive valves spool (displacement) position is needed

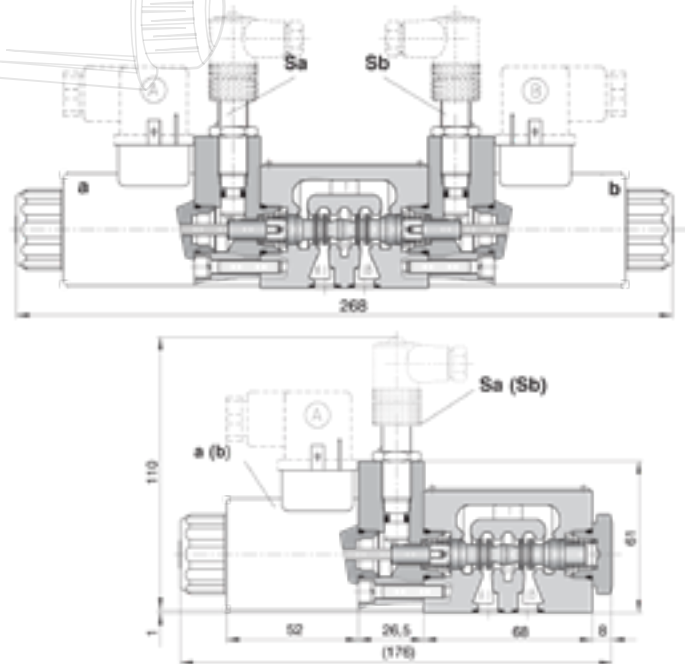

### Technical data of the Sensor

Supply Voltage	24 V DC
Supply voltage range	10..30 V DC
Rated current	200 mA
Protection	IP67
Max. operating Pressure	50 bar (standard) - 210 bar (optional)
Indication	yellow led

## 16 SOLENOID COILS types B03-xxxx

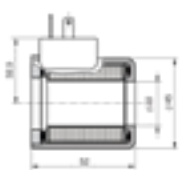

ISO 4400 (DIN 43650)  
(standard configuration)  
B03-0xxC

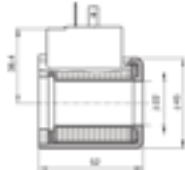

115A/230A = ISO 4400 (DIN 43650)  
with integrated rectifier  
B03-xxxA



AMPX = Amp Junior Timer with  
axial configuration  
B03-0xxCAMPX

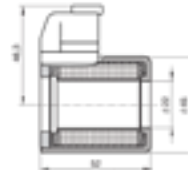

D = Deutsch  
B03-0xxD

## 17 QUENCHING DIODE

On request, DC coils can be supplied with an integrated bidirectional quenching diode (transil type BZW06-19B) able to provide high overvoltage protection. Their instantaneous response to transient overvoltages makes them particularly suited to protect voltage sensitive devices

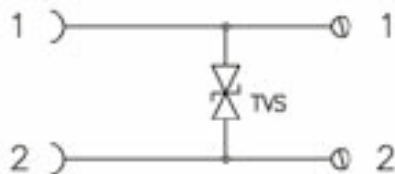

## 18 CONNECTORS FOR ISO 4400 (DIN 43650) series KA132

Connectors are available for coils with ISO 4400 (DIN 43650) connection. Most common configuration are: Standard, simple, 3 pin connectors:



- KA132000B9 = black with PG9
- KA132000B1 = black with PG11
- KA132000A1 = grey with PG11
- KA132L34T9 = transparent with led indication
- KA132T54T9 = transparent with led indication and diode transil for protection against overvoltages

For more details and models see aidro table KA-132

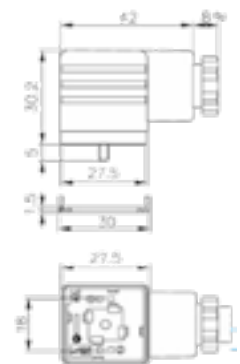



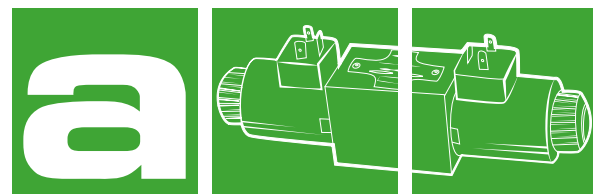

## DIRECTIONAL CONTROL VALVES SOLENOID OPERATED

### HD3-ES-\*/-20

60 l/min - 32 MPa (320 bar)

#### 1 DESCRIPTION

Valves HD3-ES are directional control valve with subplate mounting interface acc. to ISO 4401, DIN 24340 (CETOP 03).

The design of the body is a high quality five chamber casting.

The valve is available with interchangeable metallic DC solenoids, also for AC power supply using a built-in rectifier bridge inside the coil.

In the standard version, the valve housing is phosphated for 240 h salt spray protection acc. to ISO 9227. Enhanced surface protection for mobile sector available (ISO 9227, 520 h salt spray).

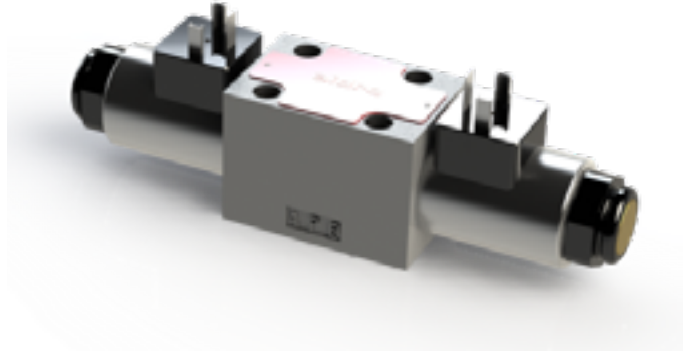

#### 2 ORDERING CODE

(1)	(2)	(3)	(4)	(5)	(6)	(7)
HD3	-	ES	-	-	-	/ 20

(1) HD3: 4-way directional control valve CETOP 03

(2) Electrically controlled

(3) Spool type (see 4):

-number is the main spool type

-letter is the solenoid or spring arrangement:

C : 2 solenoids, spool is spring centered (3 position)

LL : 1 solenoid, spool is spring offset (2 position)

ML : 1 solenoid, spool is spring centered (2 position)

(4) Code reserved for option and variants:

S-\*\*: calibrated orifice on P port, see 11

K : Water proof caps on emergency pin, see 10

(5) Electric voltage and solenoid coils: see 6

0000: no coils

012C: coils for V12DC

024C: coils for V24DC

115A: coils for V110/50- V 115/60AC

230A: coils for V220/50- V 230/60AC

(6) Coil connection

no designation: DIN 43650-A ISO 4400

AMP: Amp Junior Timer- vertical configuration, see 12

AMPX: Amp Junior Timer- axial configuration, see 12

D: Deutsch, see 12

(7) Design number (progressive) of the valves

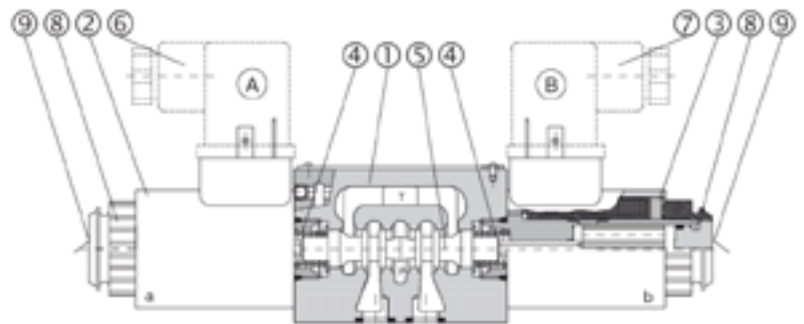
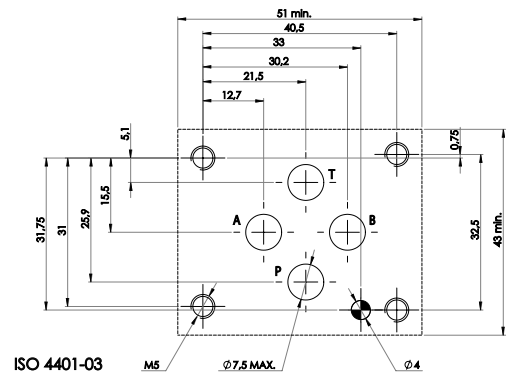

The spool 5 shifts into the valve body 1 subject to the acting springs 4 and solenoids 9. Spool 5 depending from its shape and its position in the valve body 1, opens and/ or closes passages between P,A,B and T ports, thus controlling the direction of the hydraulic flow.

### 3 TECHNICAL DATA

Nominal flow	50 l/min	<b>Electric characteristics:</b> Valve type HD3-ES-* are operated by solenoid that are energized : Directly from a D.C. voltage supply: V 12 DC = 012C V 24 DC = 024C By the use of coils that incorporate a full wave bridge rectifier, from A.C. voltage supply: V 110/50 - V 115/60 = 115A V 220/50 - V 230/60 = 230A Other available voltages are : 014C ; 048C ; 060C ; 102C ; 205C ; and V24/50 = 024A All connectors must conform to ISO 4400 (DIN 43650) and electric circuitry must be able to carry the following rated current values : V 12 DC = 2,4 A V 115/50 = 0,26 A V 24 DC = 1,2 A V 230/50 = 0,14 A Coils with 2 electric pins, conforming with AMP connectors, are only available for DC supply (example of code : B02-012C AMP)). Permissible supply voltage variation : ± 10 %
Maximum rec. flow rate	60 l/min	
Maximum nominal pressure (P, A, B)	32 MPa (320 bar)	
Maximum pressure at T port	21 MPa (210 bar)	
Pressure drops	see 5	
Protection to DIN 40050	IP 65	
Duty cycle	100%	
Installation and dimensions	see 9	
Mass	1,6/1,2 kg	

### 4 SPOOL IDENTIFICATION AND INTERMEDIATE POSITION TRANSITORIES

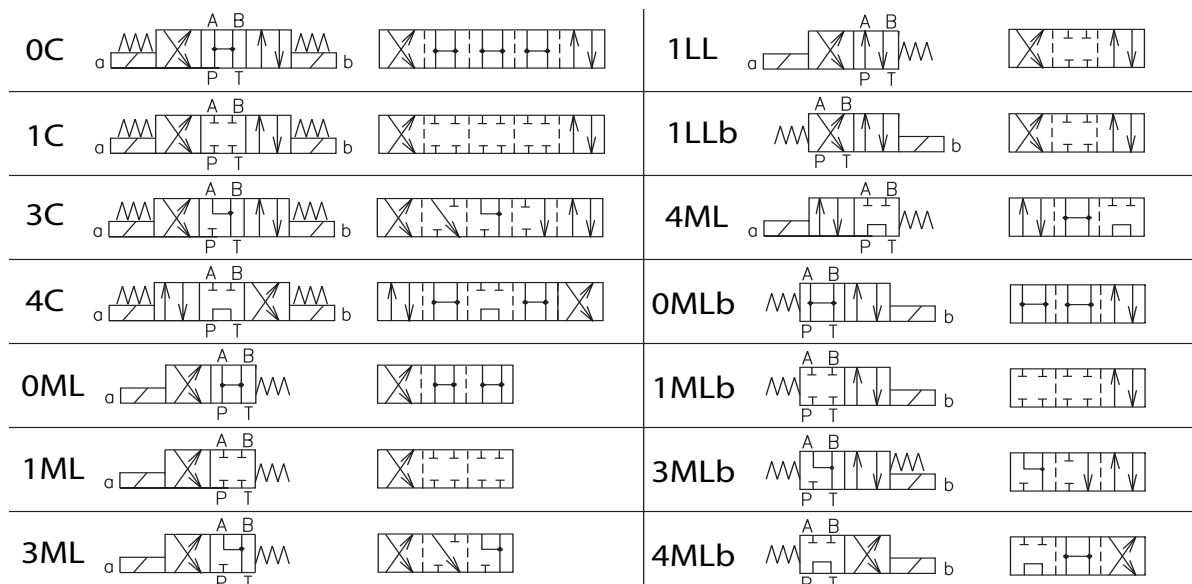

### 5 TYPICAL DIAGRAMS

Typical  $\Delta p$ -Q curves for valves HD3-ES-\* in standard configuration, with mineral oil at  $v=32 \text{ mm}^2/\text{s}$  and  $T=40^\circ\text{C}$

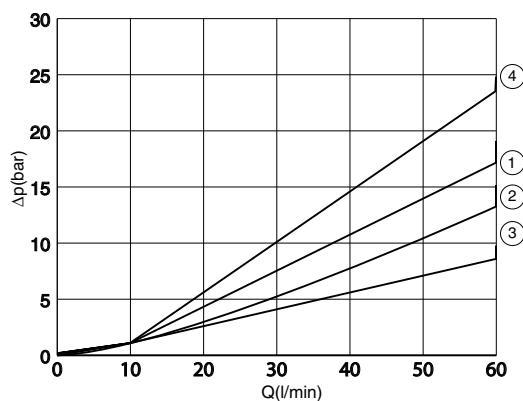

Spool	P-A	P-B	A-T	B-T	P-T
1C	2	2	2	2	
4C	4	4	4	4	2
0C	2	2	3	3	2
3C	2	2	3	3	
1LL	3	3	4	4	
1LLb	3	3	4	4	
1ML		2	2		
4ML	4		4		2
0ML	2		3		2
3ML	2		2		

## 6 SOLENOID

Solenoid valves can be supplied without electric coils, as HD3-ES-\*\*\*\*-0000. Coils are supplied separately; standard, 3 electric pins, coils are : - B02-012C ; B02-024C - B02-115A ; B02-230A Connections to the electric supply is made by standard 3-PIN connectors, according to ISO 4400 (DIN 43650). Connectors can be with different cable exit size (PG9, PG11) and beside of the plain connecting function they may incorporate various features like -Signal led - Voltage surge suppressor, etc.

## 8 HYDRAULIC FLUID

Seals and materials used on standard valves HD3-\* are fully compatible with hydraulics fluids of mineral base, upgraded with antifoaming and anti oxidizing agents. The hydraulic fluid must be kept clean and filtered to ISO 4406 class 19/17/14, or better, and used in a recommended viscosity range from 10 cSt to 60 cSt.

## 9 INSTALLATION DIMENSIONS (mm)

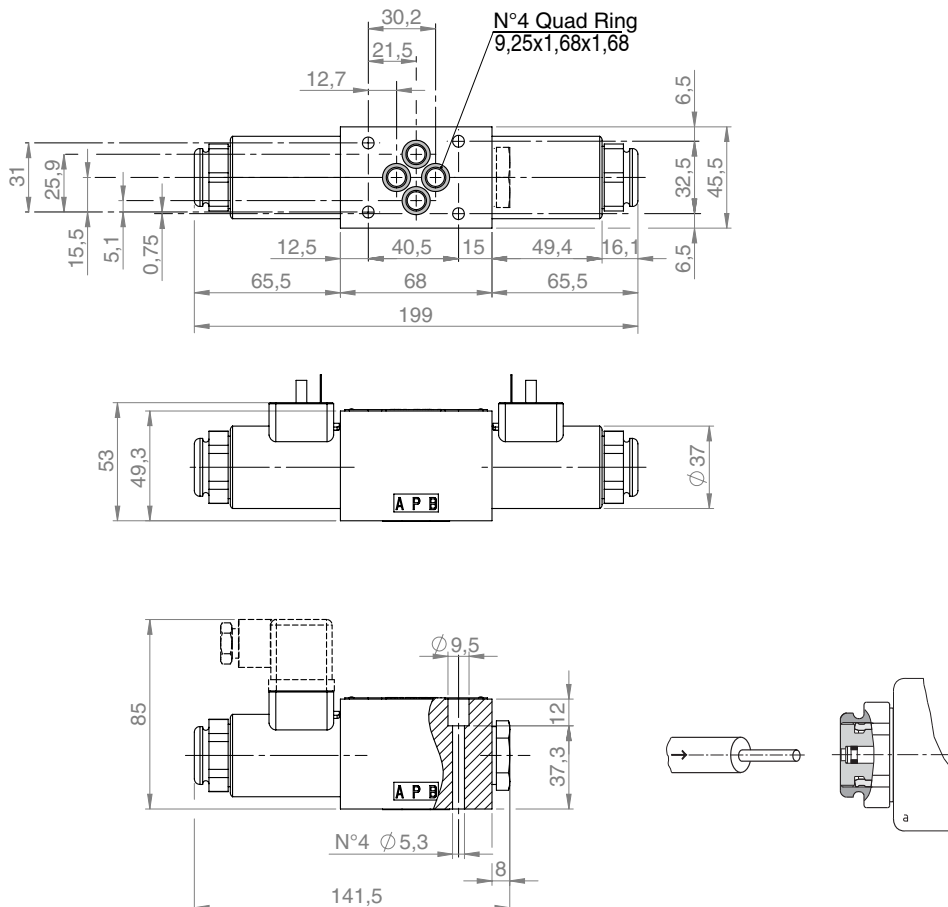

## 7 HYDRAULIC LIMIT OF USE

$\Delta p$ -Q characteristics limits for safe use of HD3-ES-\* solenoid operated valves. Measured at  $v = 32\text{mm}^2/\text{s}$  and  $T = 40^\circ\text{C}$

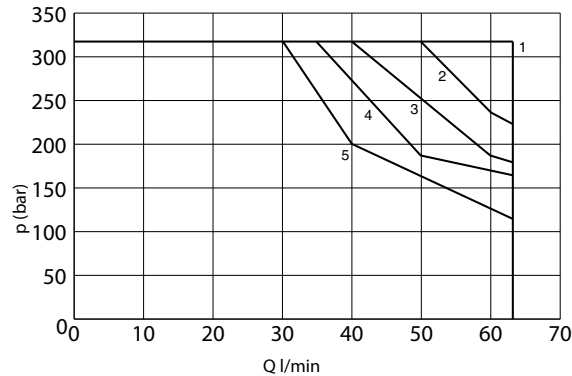

1C	1
4C	5
0C	1
3C	2
1LL	3
3ML	2
4ML	5
1ML	1
0ML	1
1MLb	1
1LLb	1
4MLb	5
0MLb	1
3MLb	2

All valves HD3-\* conform with ISO and CETOP specifications for mounting surface dimensions (see 8) and for valves height. When assembled to its mounting plate valve HD3-\* must be fastened with 4 bolts M5x45 (or M5x\*\* according to the number of modules) tightened at 8 Nm torque. Leakage between valve and mounting surface is prevented by the positive compression on their seats of 4 seals of Quad Ring type 9,25x1,68x1,68

## 10 VERSION "K": OVERRIDE PIN

Solenoid valves according to "K" version have extended emergency actuator pins protruding from the solenoid shape, that permit a quick and easy "hand operation" of the valves, without the need of any tool. The actuator pin and the end of the solenoid are protected by a flexible rubber cap that makes easy operation and protects from moisture and water splashes

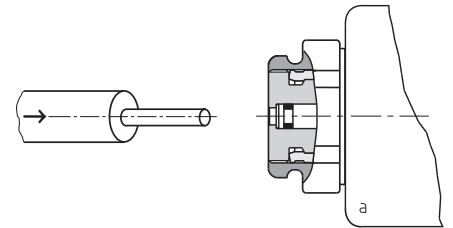

## 11 VERSION "S\*"; CALIBRATED ORIFICE ON P PORT

Option "S\*" is represented by an element suitably shaped to be inserted on P port of the solenoid valve, having a calibrated orifice (of various sizes) able to restrict, depending on the  $\Delta P$  value, the flow rate entering the solenoid valve.

Those elements have the following orifice diameters :

- 3S-00 -> D = 0 mm
- 3S-10 -> D = 1,0 mm
- 3S-15 -> D = 1,5 mm
- 3S-20 -> D = 2,0 mm
- 3S-25 -> D = 2,5 mm

and are kept sealed on the P port of the valve by an OR of 9,25x1,78 mm sizes (example OR 110-2037)

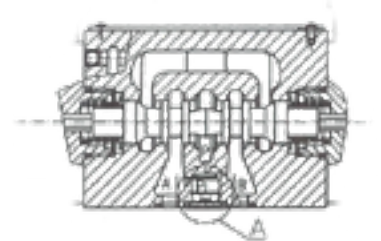
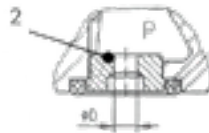

## 12 SPECIAL COIL CONNECTIONS

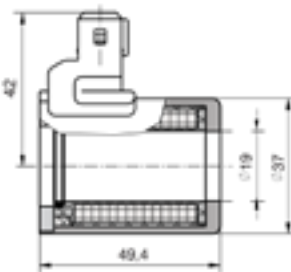

AMP = Amp Junior Timer  
vertical configuration

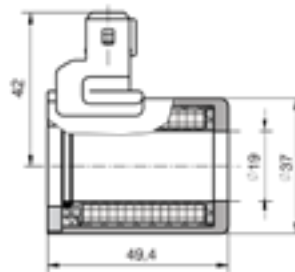

AMP = Amp Junior Timer  
axial configuration

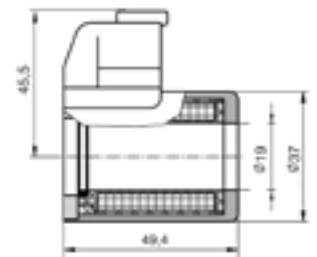

D = Deutsch

## 13 QUENCHING DIODE

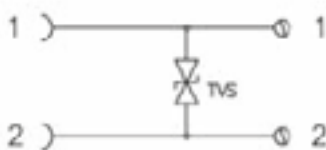

On request, coils can be supplied with an integrated bidirectional quenching diode (transil type BZW06-19B) able to provide high overvoltage protection. Their instantaneous response to transient overvoltages makes them particularly suited to protect voltage sensitive devices

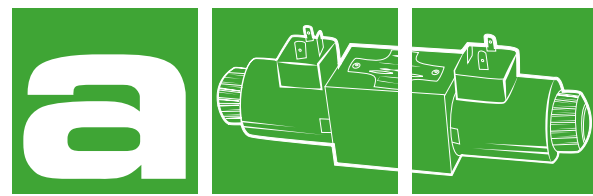

## DIRECTIONAL CONTROL VALVES SOLENOID OPERATED

### HD33-EF-\*

40 l/min - 25 MPa (250 bar)

#### 1 DESCRIPTION

Valves HD33-EF are directional control valve with subplate mounting interface acc. to ISO 4401, DIN 24340 (CETOP 03).

The design of the body is a three chamber casting for production cost saving and low pressure drops. HD33-EF has a low power consumption (18 W) and a compact design.

The valve is available with interchangeable metallic DC solenoids, also for AC power supply using connectors with a built-in rectifier bridge.

In the standard version, the valve housing is phosphated for 240 h salt spray protection acc. to ISO 9227. Enhanced surface protection for mobile sector available (ISO 9227, 520 h salt spray).

#### 2 ORDERING CODE

(1)	(2)	(3)	(4)	(5)	(6)	(7)
HD33	-	EF	-	-	-	/

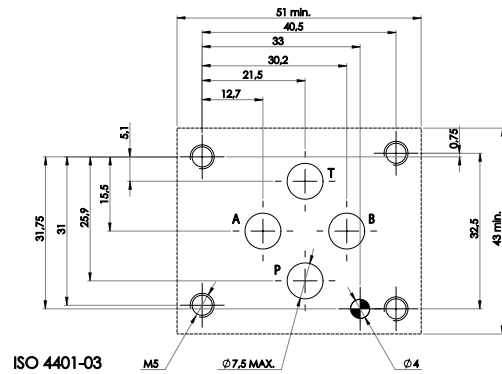
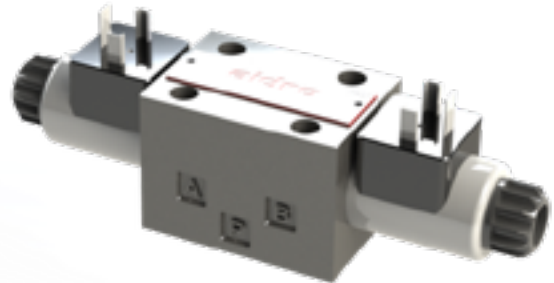

(1) HD33: 4-way directional control valve CETOP 03

(2) Electrically controlled

(3) Spool type (see 4):

-number is the main spool type

-letter is the solenoid or spring arrangement:

C : 2 solenoids, spool is spring centered (3 position)

LL : 1 solenoid, spool is spring offset (2 position)

ML : 1 solenoid, spool is spring centered (2 position)

(4) Code reserved for option and variants

(5) Electric voltage and solenoid coils: see 6

0000: no coils

012C: coils for V12DC

024C: coils for V24DC

(6) Coil connection

no designation: DIN 43650-A ISO 4400

AMPX: Amp Junior Timer

(7) Design number (progressive) of the valves

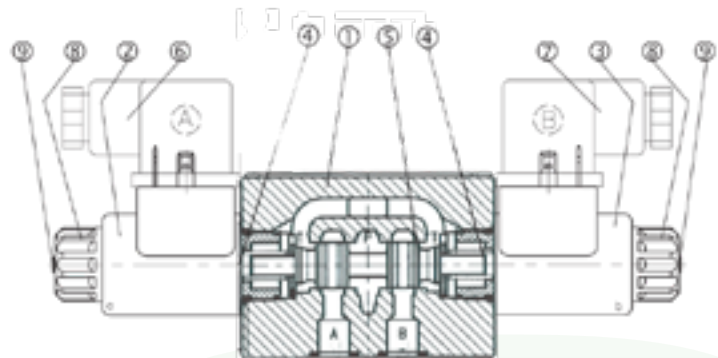

The spool 5 shifts into the valve body 1 subject to the acting springs 4 and solenoids 9. Spool 5 depending from its shape and its position in the valve body 1, opens and/ or closes passages between P,A,B and T ports, thus controlling the direction of the hydraulic flow.

### 3 TECHNICAL DATA

Nominal flow	25 l/min	<b>Electric characteristics:</b> Valve type HD33-EF-* are operated by solenoid that are energized : directly from a D.C. voltage supply V 12 DC = 012C V 24 DC = 024C 3 pin connectors must conform to ISO 4400 (DIN 43650) Permissible supply voltage variation : ± 10 %
Maximum rec. flow rate	40 l/min	
Maximum nominal pressure (P, A, B)	25 MPa (250 bar)	
Maximum pressure at T port	16 MPa (160 bar)	
Pressure drops	see 5	
Protection to DIN 40050	IP 65	
Duty cycle	100%	
Installation and dimensions	see 9	
Mass	1,25/1,10 kg	

### 4 SPOOL IDENTIFICATION AND INTERMEDIATE POSITION TRANSITORIES

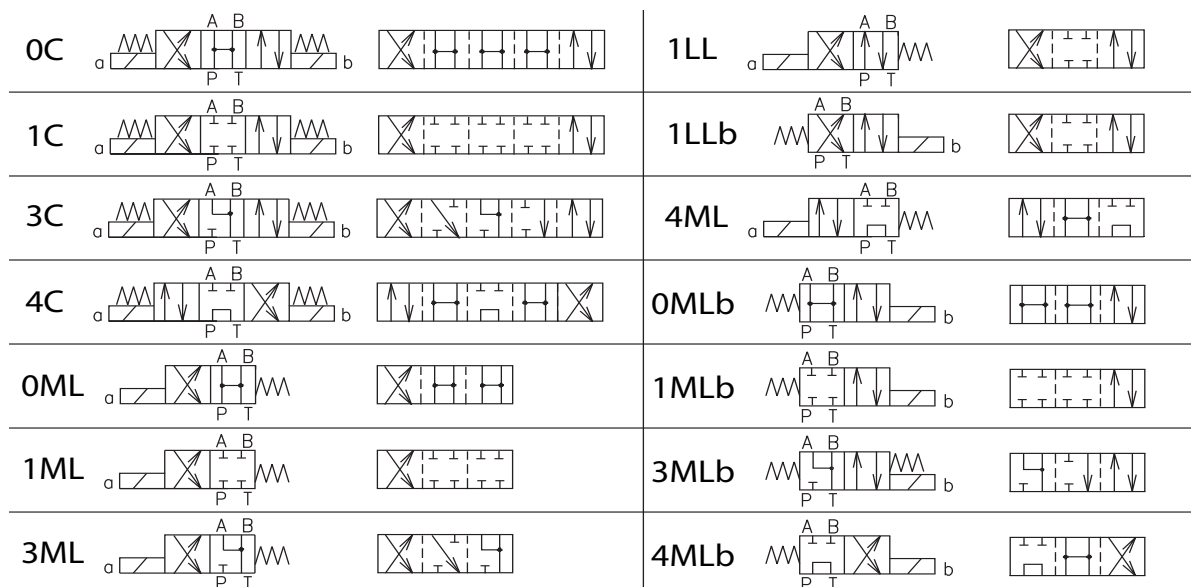

### 5 TYPICAL DIAGRAMS

Typical  $\Delta p$ -Q curves for valves HD33 -EF-\* in standard configuration, with mineral oil at  $v=32 \text{ mm}^2/\text{s}$  and  $T=40^\circ\text{C}$

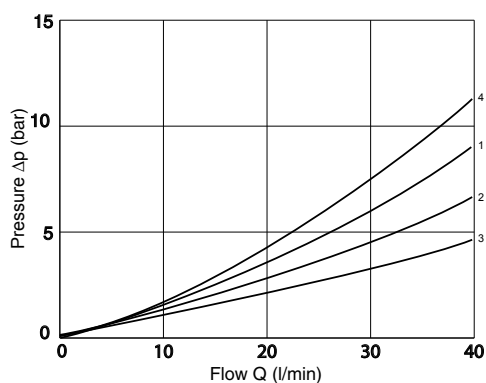

Spool	P-A	P-B	A-T	B-T	P-T
1C	2	2	2	2	
4C	4	4	1	1	1
0C	2	2	3	3	1
3C	2	2	3	3	
1LL	1	1	1	1	
1LLb	1	1	1	1	
1ML		2	2		
4ML	4		1		1
0ML	2		3		1
3ML	2		3		

## 6 SOLENOID

Solenoid valves can be supplied without electric coils, as HD33-EF-\*\*\*\*-0000. Coils are supplied separately; standard, 3 electric pins, coils are : - B01-012C - B01-024C. Connections to the electric supply is made by standard 3-PIN connectors, according to ISO 4400 (DIN 43650). Connectors can be with different cable exit size (PG9, PG11) and beside of the plain connecting function they may incorporate various features like - Signal led - Voltage surge suppressor, etc.

## 8 HYDRAULIC FLUID

Seals and materials used on standard valves HD33-\* are fully compatible with hydraulics fluids of mineral base, upgraded with antifoaming and anti oxidizing agents. The hydraulic fluid must be kept clean and filtered to ISO 4406 class 19/17/14, or better, and used in a recommended viscosity range from 10 cSt to 60 cSt.

## 9 INSTALLATION DIMENSIONS (mm)

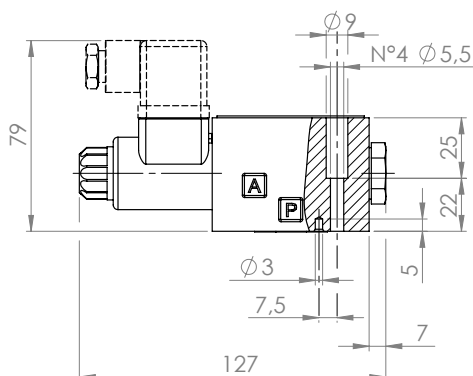
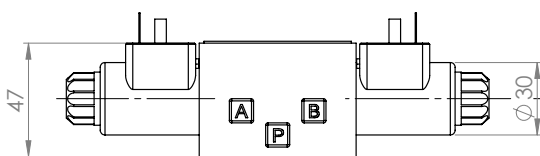
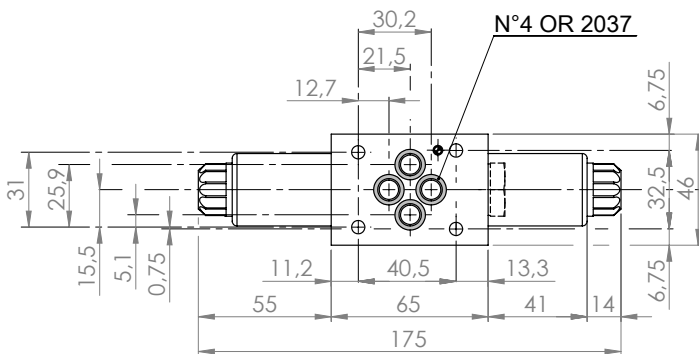

## 7 HYDRAULIC LIMIT OF USE

$\Delta p$ -Q characteristics limits for safe use of HD33-EF-\* solenoid operated valves. Measured at  $v = 32\text{mm}^2/\text{s}$  and  $T = 40^\circ\text{C}$

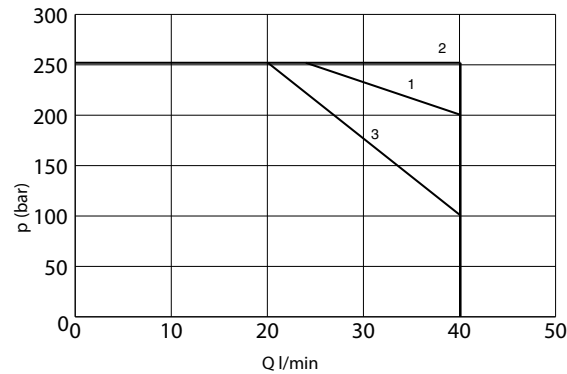

1C	2
4C	3
0C	1
3C	3
1LL	1
3ML	3
4ML	3
1ML	2
0ML	1
1MLb	2
1LLb	1
4MLb	3
0MLb	1
3MLb	3

All valves HD33-\* conform with ISO and CETOP specifications for mounting surface dimensions and for valves height. When assembled to its mounting plate valve HD33-\* must be fastened with 4 bolts M5x45 (or M5x\*\* according to the number of modules) tightened at 8 Nm torque. Leakage between valve and mounting surface is prevented by the positive compression on their seats of 4 seals of O Ring type 9,25x1,78

## 10 MANUAL OVERRIDE

In case of electric cut-offs, the spool can be manually shifted by acting on the emergency pins, located at the end of the solenoids and accessible through the retaining nuts.

Standard model of the manual override

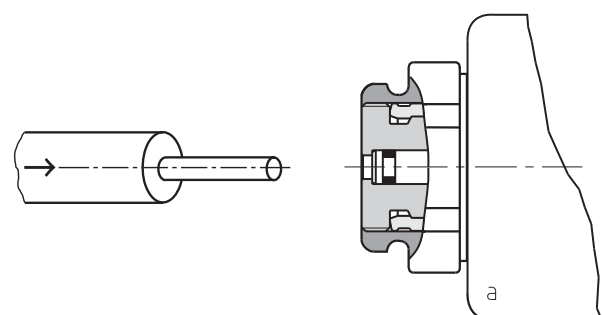

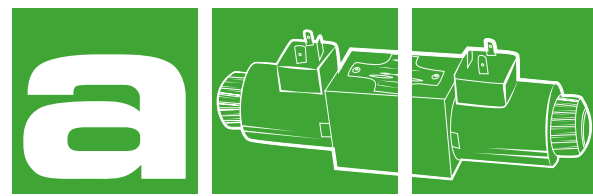

## DIRECTIONAL CONTROL VALVES LEVER OPERATED

### HD3-LO-\*

60 l/min - 32 MPa (320 bar)

#### 1 DESCRIPTION

The hand operated directional control valves are used mainly to control start, stop and direction of fluid. Manual lever and actuating section can be rotated in 90° increments for flexible installation. The directional control valves are being manufactured as two-position and three-position valves (see table with functional symbols). In the standard version, the valve housing is phosphated and steel parts zinc-coated for 240 h salt spray protection acc. to ISO 9227. Enhanced surface protection for mobile sector available (ISO 9227, 520 h salt spray).

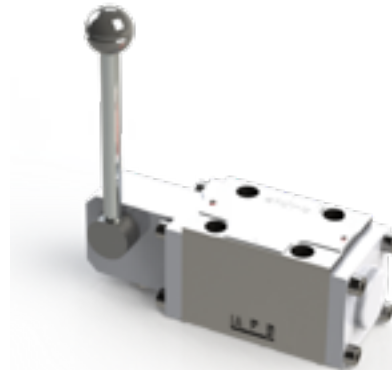

#### 2 ORDERING CODE

(1)	(2)	(3)	(4)	(5)	(6)
HD3	-	LO	-	b	/ 10

(1) HD3: 4-way directional control valve CETOP 03 - Pressure 32 MPa (320bar)

(2) Standard, level operated

(3) Spool type (see 4):

-number is the main spool type

-letter is the spring arrangement:

C : spool is spring centered (3 position)

D : spool is detented (3 position)

N : spool is detented (2 position, end to end)

LL : spool is spring offset (2 position, end to end)

ML: spool is spring offset (2 position, middle to end)

(4) b: lever mechanism on B port side

(5) Code reserved for option and variants

(6) Design number (progressive) of the valves

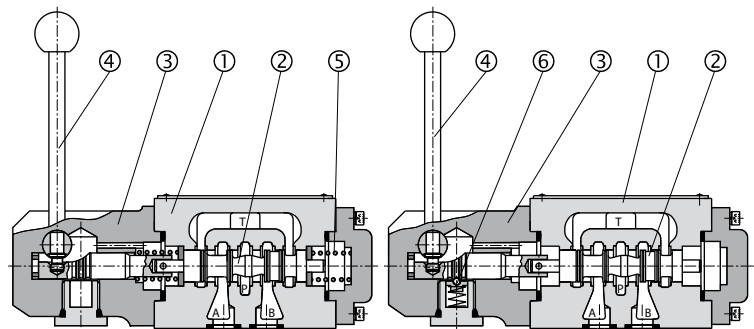
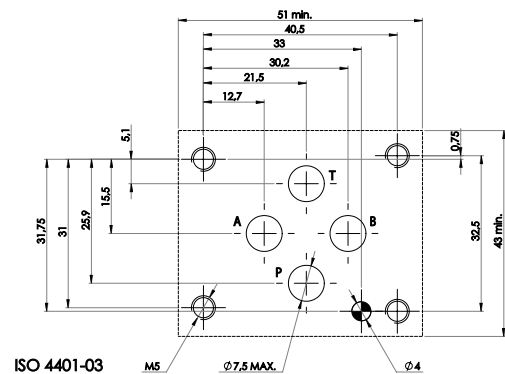

Type with return springs

Type with detent assembly

The hand operated directional valves are used mainly to control start, stop and direction of fluid. they consist of housing 1 with control spool 2 and the actuating section 3. the actuating section consists either of the hard lever 4 and of one or two return springs 5, or of the hand lever 4 and the detent assembly 6. The detent assembly holds the spool in its last shifted position.



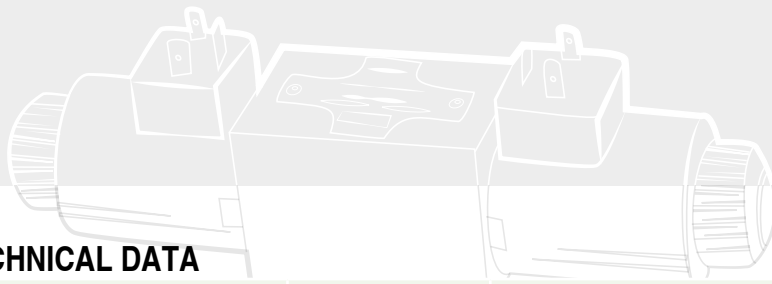

### 3 TECHNICAL DATA

Maximum nominal flow	60 l/min	Pressure drops: $\Delta p$ -Q characteristics
Maximum rec. flow rate	80 l/min	
Maximum nominal pressure (P, A, B)	32 MPa (320 bar)	
Maximum pressure at T port	10 MPa (100 bar)	
Installation and dimensions	see 5	
Mass	approx 1,6 kg	

- ① P -> A, P -> B spool 0,8
- ② -> ③ spool 0,1,2,3,4,7
- ④ A -> T, B -> T spool 4
- ⑤ P -> T spool 4

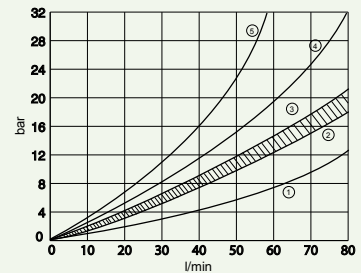

### 4 SPOOL IDENTIFICATION AND INTERMEDIATE POSITION TRANSITORIES

1C			1D		
4C			4D		
0C			0D		
8C			8D		
3C			3D		
7C			7D		
1LL			1N		
2LL			2N		
0LL			0N		

### 5 INSTALLATION DIMENSIONS (mm)

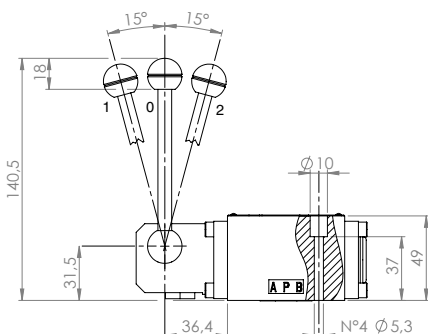
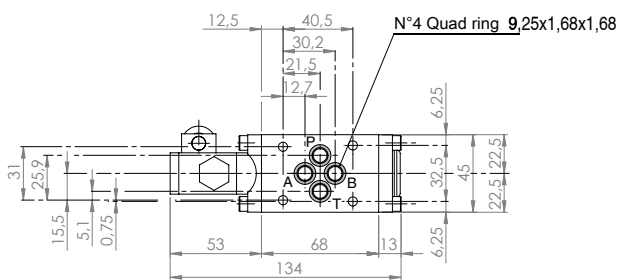

### 6 HYDRAULIC LIMITS OF USE

Valves HD3-LO-1C, 1LL and all detent type valve can operate at 320 bar and 80 l/min. Other spring centered and spring offset valves have limits reduced to max 60l/min

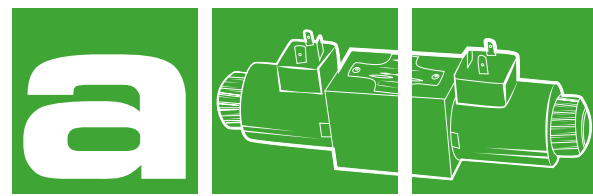

## FLOW RESTRICTOR VALVES

### AM3-FO-\*

60 l/min - 32 MPa (320 bar)

#### 1 DESCRIPTION

Stackable valve CETOP 3 with flow restrictor function. It is possible to control the lines A, B or AB simply turning the side screws.  
On demand it is possible to have also the fine control option.



#### 2 ORDERING CODE

(1)	(2)	(3)	(4)	(5)	(6)
AM3	-	FO	-	-	/ 10

(1) AM3: stackable valve CETOP 03 - Pressure 32 MPa (320 bar)

(2) FO: flow restrictor valves with two-way control

(3) Service lines where the controls operates:

AB: controls on A and B. Fluid flows restricted A <-> A, and B <-> B

A : flow is restricted A<-> A; free on B, P and T

B : flow is restricted B<-> B; free on A, P and T

(4) Flow control characteristics

no designation: standard control

V: fine control

(5) Code reserved for option and variants

(7) Design number (progressive) of the valves

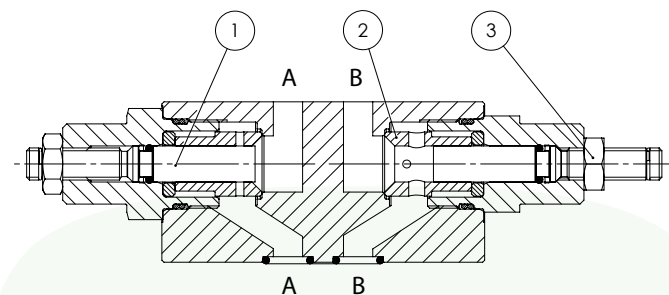
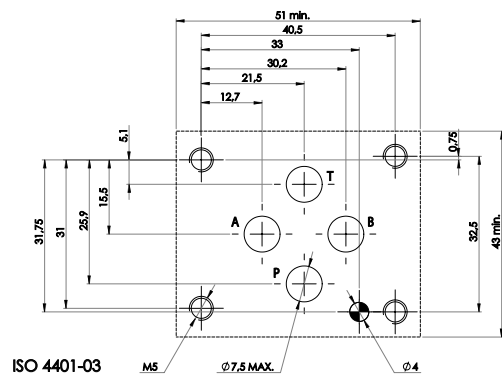

AM3-FO-AB

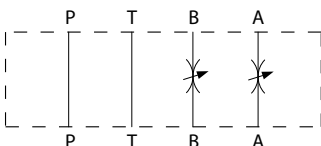

AM3-FO-B

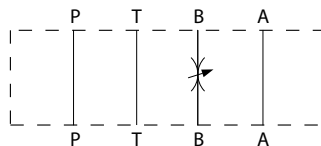

AM3-FO-A

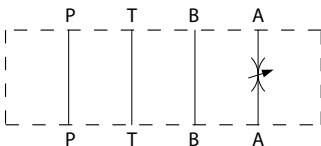

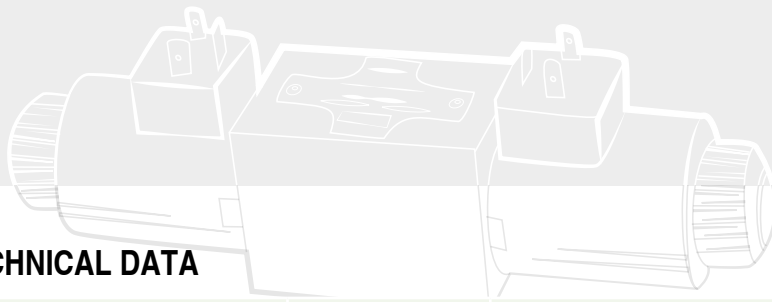

### 3 TECHNICAL DATA

Maximum nominal flow		Control of the flow:
Maximum rec. flow rate	60 l/min	The control is made by throttling from through variable orifices obtained on sleeve and partially obstructed by throttling axis. Depending on the various sleeve/axis combination, the control adjustment is:
Maximum nominal pressure	32 MPa (320 bar)	- (standard): orifices area is reduced from 100% (*) to 0% with 6 complete turns of the adjustment screw.
Pressure drops	see [4]	- V (fine): from 100% (**) to 0% with 5 complete turns of the adjustment screw.
Installation and dimensions	see [5]	(*) 100% approx Q=60 l/min at p=20 bar
Mass	approx 1,2 kg	(**) 100% approx Q=30 l/min at p=20 bar
		The axis is shifted to increase throttling by unlocking its nut and turning clock wise the adjustment screw.
		Suitable mechanical stops prevent dangerous manoeuvring.

### 4 TYPICAL DIAGRAMS

Typical  $\Delta p$ -Q curves for valves AM3-FO-\* in standard configuration, with mineral oil at 36 cSt and at 50°C with throttling axis at full retraction.

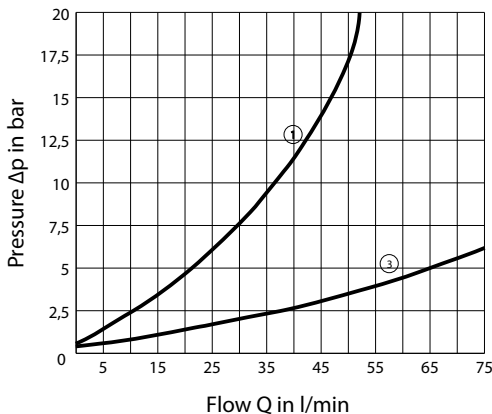

① controlled channels      ③ controlled channels

### 5 INSTALLATION DIMENSIONS (mm)

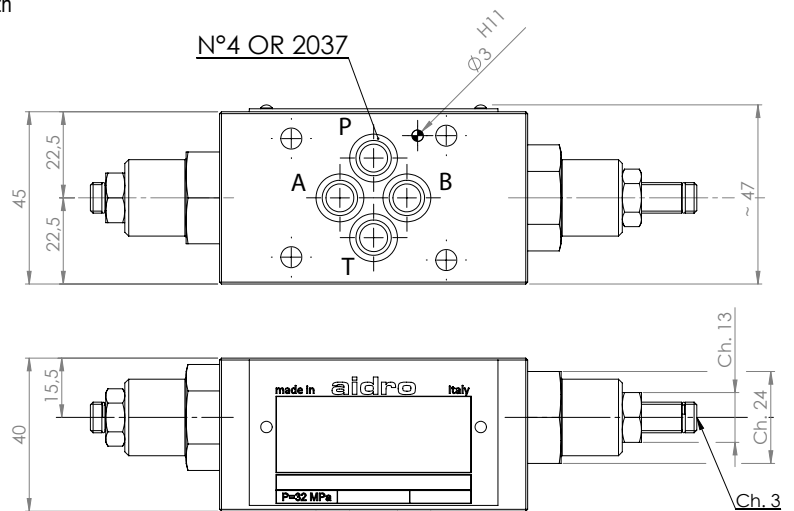

### 6 HYDRAULIC FLUIDS

Seals and materials used on standard valves AM3-\* are fully compatible with hydraulic fluids of mineral oil base, upgraded with antifoaming and antioxidantizing agents. The hydraulic fluid must be kept clean and filtered to ISO 4406 class 19/17/14, or better, and used in a recommended viscosity range from 10 cSt to 60 cSt.

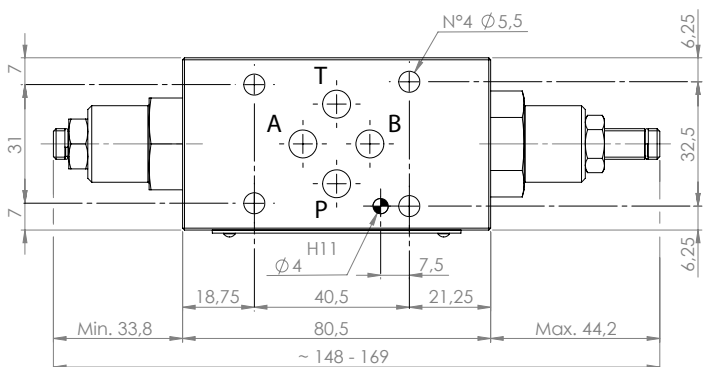

All stackable valves AM3-FO-\* conform with ISO and CETOP specifications for mounting surface dimensions. Valves height 40 mm.

Leakage between valve and mounting surface is prevented by the positive compression on their seats of 4 seals of OR type. All valves have on their "mounting" surface a  $\phi$  4 mm cylindrical hole and have on their "seals" surface a  $\phi$  3 mm cylindrical hole, conform with ISO and CETOP norms.

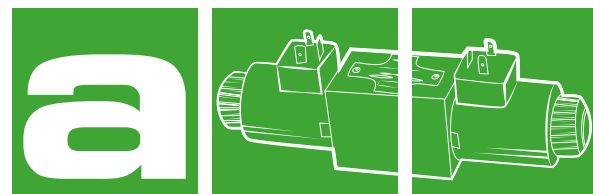

## FLOW CONTROL VALVES

### AM3-FC-\*

60 l/min - 32 MPa (320 bar)

#### 1 DESCRIPTION

Stackable valve CETOP 3 with meter out control (referred to the hydraulic actuator). It is possible to control the lines A, B or AB simply turning the side screws.

On demand it is possible to have also the fine control option.



#### 2 ORDERING CODE

(1)	(2)	(3)	(4)	(5)	(6)
AM3	-	FC	-	-	/ 10

(1) AM3: stackable valve CETOP 03 - Pressure 32 MPa (320 bar)

(2) FC: one way flow control valves with meter-out control (referred to the hydraulic actuator)

(3) Service lines where the controls operate:

- AB: controls on A and B. Fluid flows unrestricted from A <-> A1 and flow is controlled from A1 -> A and B1 -> B
- A : flow is controlled from A1 <-> A, free on B
- B : flow is controlled from B1 <-> B; free on A

(4) Flow control characteristics for A1 -> A and B1 -> B) and check valve opening pressure (Pm) for flow A ->A1 and B -> B1

- no designation: standard control and Pm approx 0,04 MPa (0,4 bar)
- V: fine control
- 4: Pm approx 0,4 MPa (4 bar)

(5) Code reserved for option and variants

(6) Design number (progressive) of the valves

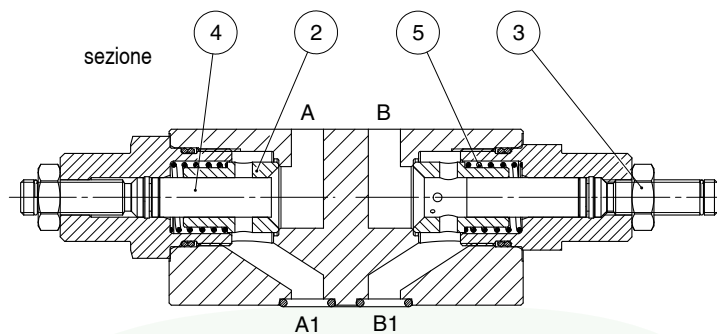
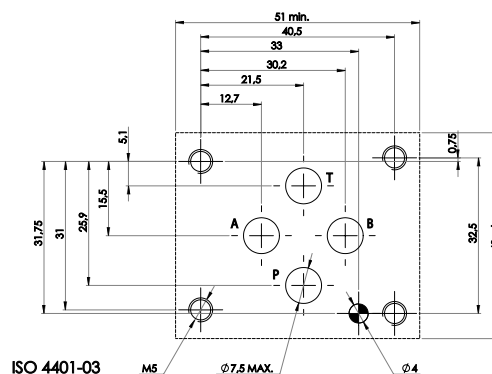

#### AM3-FC-AB



#### AM3-FC-A



#### AM3-FC-B

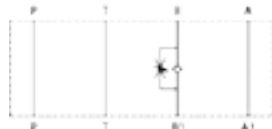

Fluids flows freely on P and T lines: on service lines A and/or B with controls, fluid flows from A -> A1 (and/or B-> B1) overcoming the force of spring 5 acting on sleeve 2; fluid flows from A1-> A (and/or B1->B) through orifices to sleeve 2 which is pushed against its seat; the throttling axis 4, which is shifted by screwing it and locked by its nut 3, partially obstructs the control orifices, thus making the flow rate entirely dependent upon the available pressure drop.

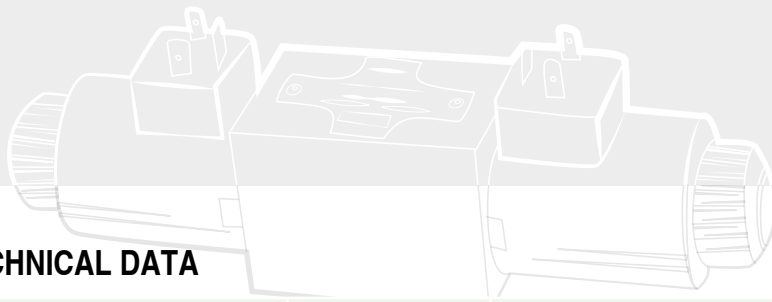

### 3 TECHNICAL DATA

Maximum nominal flow		Control of the flow:
Maximum rec. flow rate	60 l/min	The control is made by throttling from through variable orifices obtained on sleeve and partially obstructed by throttling axis. Depending on the various sleeve/axis combination, the control adjustment is:
Maximum nominal pressure	32 MPa (320 bar)	- (standard): orifices area is reduced from 100% (*) to 0% with 6 complete turns of the adjustment screw.
Pressure drops	see [4]	- V (fine): from 100% (**) to 0% with 5 complete turns of the adjustment screw.
Installation and dimensions	see [5]	(*) 100% approx Q=60 l/min at p=20 bar
Mass	approx 1,2 kg	(**) 100% approx Q=30 l/min at p=20 bar
		The axis is shifted to increase throttling by unlocking its nut and turning clock wise the adjustment screw.
		Suitable mechanical stops prevent dangerous manoeuvring.

### 4 TYPICAL DIAGRAMS

Typical  $\Delta p$ -Q curves for valves AM3-FC- \* in standard configuration, with mineral oil at 36 cSt and at 50°C with throttling axis at full retraction.

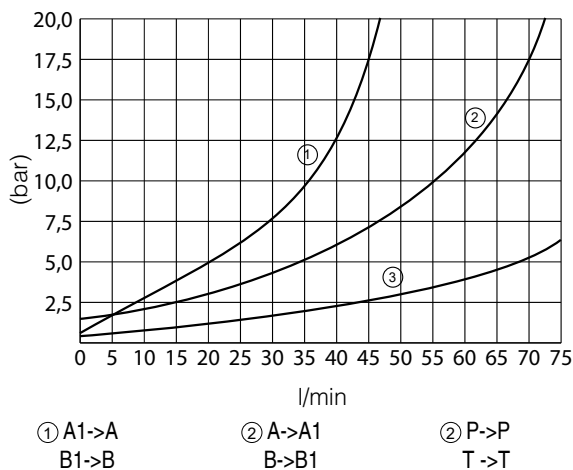

### 5 INSTALLATION DIMENSIONS (mm)

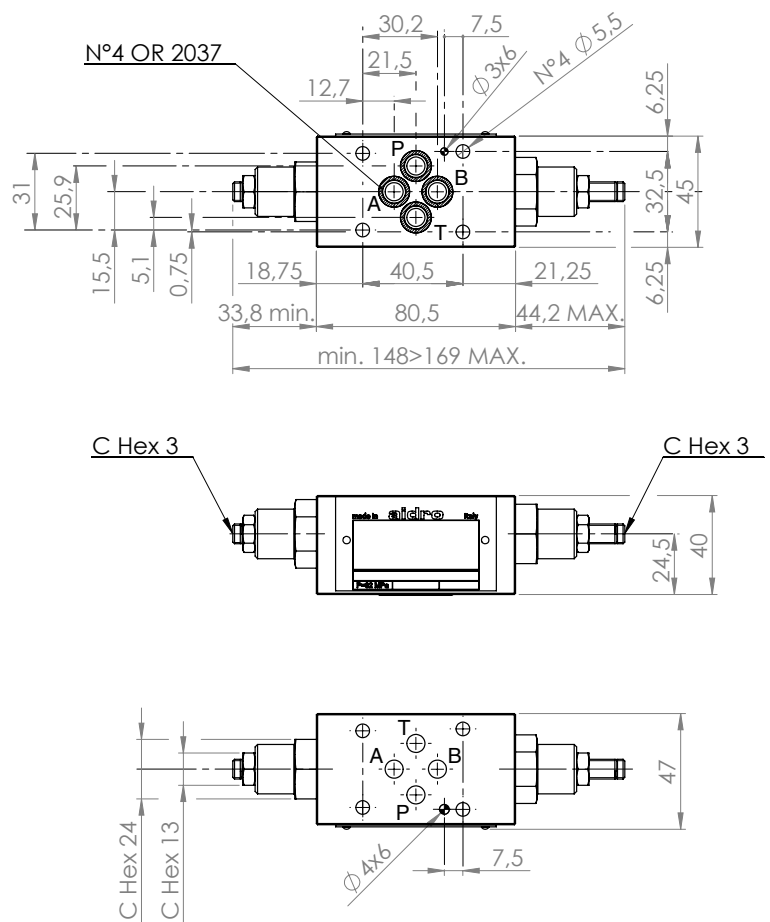

### 6 HYDRAULIC FLUIDS

Seals and materials used on standard valves AM3-\* are fully compatible with hydraulic fluids of mineral oil base, upgraded with antifoaming and antioxidantizing agents.

The hydraulic fluid must be kept clean and filtered to ISO 4406 class 19/17/14, or better, and used in a recommended viscosity range from 10 cSt to 60 cSt.

All stackable valves AM3-FC-\* conform with ISO and CETOP specifications for mounting surface dimensions. Valves height 40 mm. Leakage between valve and mounting surface is prevented by the positive compression on their seats of 4 seals of OR type. All valves have on their "mounting" surface a  $\phi$  4 mm cylindrical hole and have on their "seals" surface a  $\phi$  3 mm cylindrical hole, conform with ISO and CETOP norms.

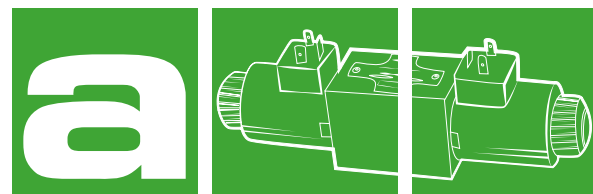

## FLOW CONTROL VALVES

### AM3-FX-\*

60 l/min - 32 MPa (320 bar)

#### 1 DESCRIPTION

Stackable valve CETOP 3 with meter in control (referred to the hydraulic actuator). It is possible to control the lines A, B or AB simply turning the side screws.

On demand it is possible to have also the fine control option.

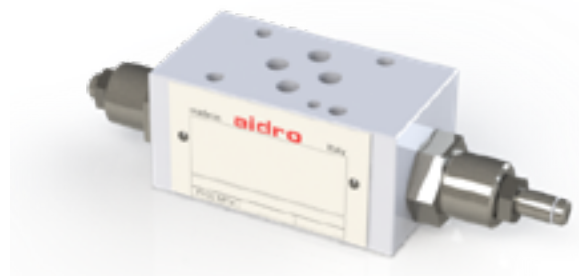

#### 2 ORDERING CODE

(1)	(2)	(3)	(4)	(5)	(6)
AM3	-	FX	-	-	/ 10

(1) AM3: stackable valve CETOP 03 - Pressure 32 MPa (320 bar)

(2) FX: one way flow control valves with meter-out control (referred to the hydraulic actuator)

(3) Service lines where the controls operate:

- AB: controls on A and B. Fluid flows unrestricted from A1-> A and B1-> B and flow is controlled from A-> A1 and B-> B1
- A : flow is controlled from A-> A1, free on B
- B : flow is controlled from B-> B1; free on A

(4) Flow control characteristics for A-> A1 and B-> B1 and check valve opening pressure (Pm) for flow A1-> A and B1-> B

- no designation: standard control and Pm approx 0,04 MPa (0,4 bar)
- V: fine control
- 4: Pm approx 0,4 MPa (4 bar)

(5) Code reserved for option and variants

(6) Design number (progressive) of the valves

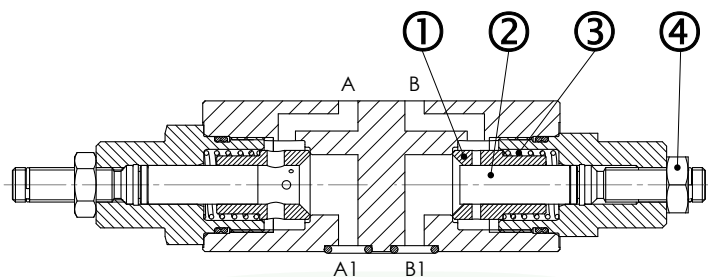
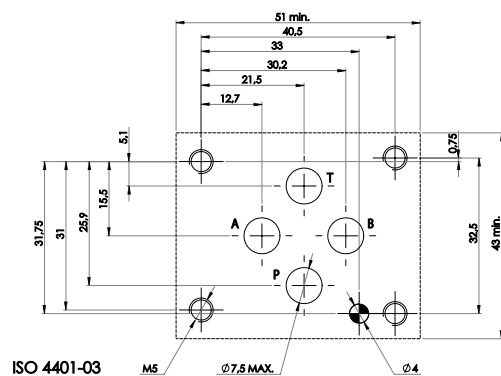

AM3-FX-AB

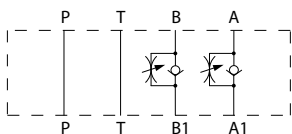

AM3-FX-A

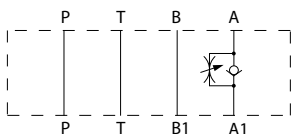

AM3-FX-B

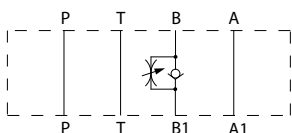

Fluids flows freely on P and T lines: on service lines A and/or B with controls, fluid flows from A-> A1 (and/or B-> B1) overcoming the force of spring 5 acting on sleeve 2; fluid flows from A1-> A (and/or B1->B) through orifices to sleeve 2 which is pushed against its seat; the throttling axis 4, which is shifted by screwing it and locked by its nut 3, partially obstructs the control orifices, thus making the flow rate entirely dependent upon the available pressure drop.

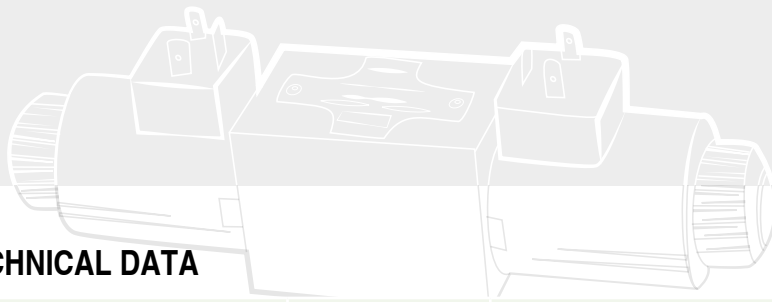

### 3 TECHNICAL DATA

Maximum nominal flow		Control of the flow:
Maximum rec. flow rate	60 l/min	The control is made by throttling from through variable orifices obtained on sleeve and partially obstructed by throttling axis. Depending on the various sleeve/axis combination, the control adjustment is:
Maximum nominal pressure	32 MPa (320 bar)	- (standard): orifices area is reduced from 100% (*) to 0% with 6 complete turns of the adjustment screw.
Pressure drops	see 4	- V (fine): from 100% (**) to 0% with 5 complete turns of the adjustment screw.
Installation and dimensions	see 5	(*) 100% approx Q=1 dm <sup>3</sup> /s (60 l/min) at p=2 MPa (20 bar)
Mass	approx 1,2 kg	(**) 100% approx Q=0,5 dm <sup>3</sup> /s (30 l/min) at p=2 MPa (20 bar)
		The axis is shifted to increase throttling by unlocking its nut and turning clock wise the adjustment screw.
		Suitable mechanical stops prevent dangerous manoeuvring.

### 4 TYPICAL DIAGRAMS

Typical p-Q curves for valves AM3-FX-\* in standard configuration, with mineral oil at 36 cSt and at 50°C with throttling axis at full retraction.

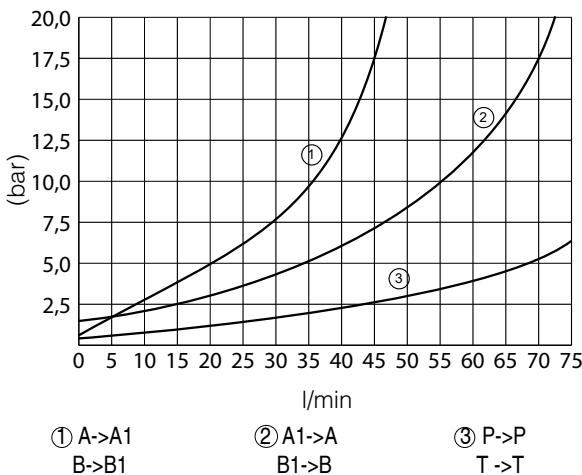

### 6 HYDRAULIC FLUIDS

Seals and materials used on standard valves AM3-\* are fully compatible with hydraulic fluids of mineral oil base, upgraded with antifoaming and antioxidizing agents. The hydraulic fluid must be kept clean and filtered to ISO 4406 class 19/17/14, or better, and used in a recommended viscosity range from 10 cSt to 60 cSt.

### 5 INSTALLATION DIMENSIONS (mm)

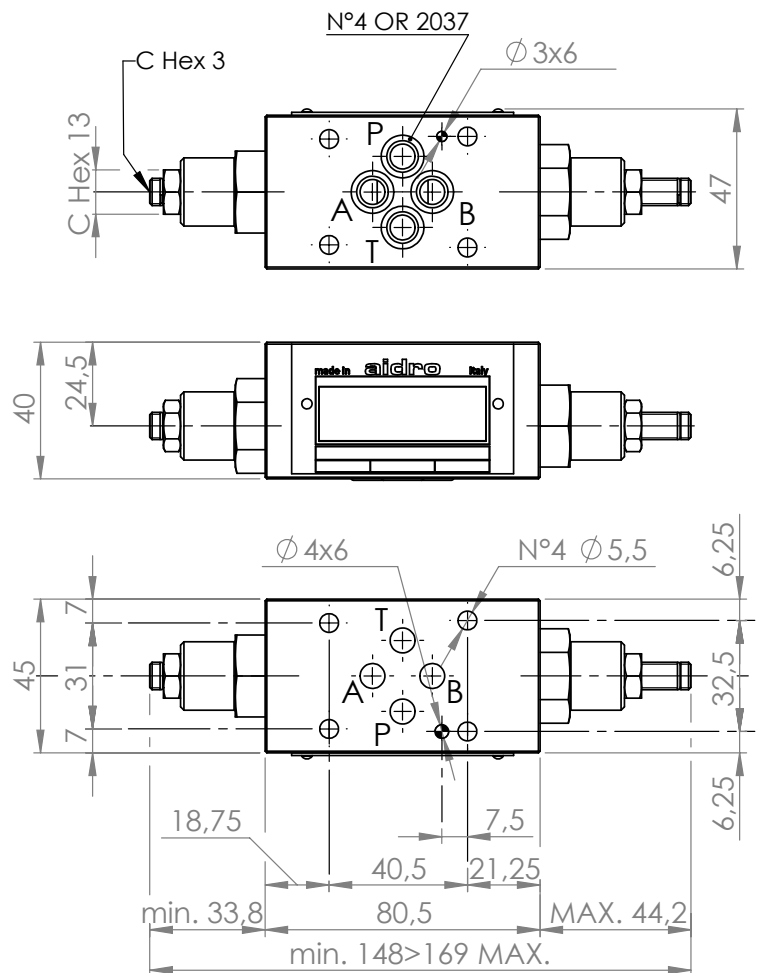

All stackable valves AM3-FX-\* conform with ISO and CETOP specifications for mounting surface dimensions. Valves height 40 mm. Leakage between valve and mounting surface is prevented by the positive compression on their seats of 4 seals of OR type. All valves have on their "mounting" surface a  $\phi$  4 mm cylindrical hole and have on their "seals" surface a  $\phi$  3 mm cylindrical hole, conform with ISO and CETOP norms.

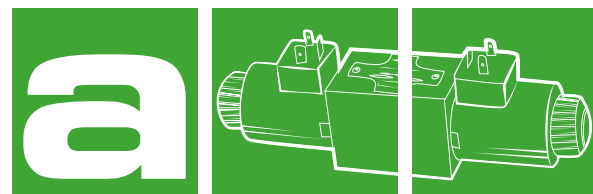

## FLOW CONTROL VALVES

### AM3-CO-\*/10

60 l/min - 32 MPa (320 bar)

#### 1 DESCRIPTION

Direct operated check valve. All the internal part are made with high strenght steel and are machined with accuracy in order to assure the requested tightness. The controlled lines are A, B or AB. The standard surafce treatment of the body is phosphate coated. Plugs are zinc coated.



#### 2 ORDERING CODE

(1)	(2)	(3)	(4)	(5)	(6)
AM3	-	CO	-	-	/ 10

(1) AM3: stackable valve CETOP 03 - Pressure 32 MPa (320 bar)

(2) CO: check valve. spring operated

(3) Service lines where the controls operate:

AB : checks on A and B. Fluid flows A->A1 and B->B1 and cannot flow A1->A, B1->B. P and T: free.

A : check on A: flow A1-> A is blocked, free on B, P and T

B : check on B: flow B1->B is blocked, free on A, P and T

(4) check valve opening (cracking) pressure (Pm):

no designation (standard): Pm approx 0.2 MPa (2 bar)

4: Pm approx 0.4 MPa (4 bar)

(5) Code reserved for option and variants

(6) Design number (progressive) of the valves

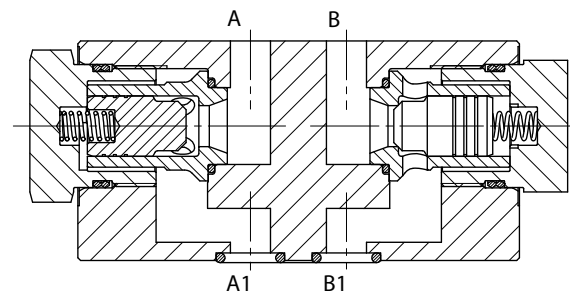
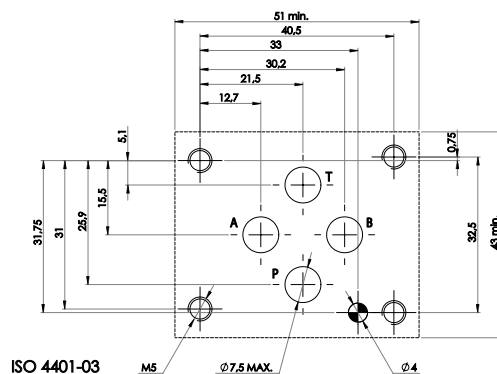

#### AM3-CO-AB

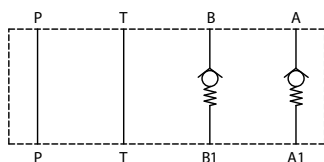

#### AM3-CO-A

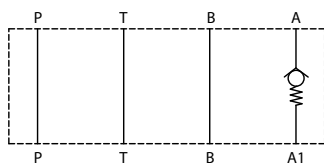

#### AM3-CO-B

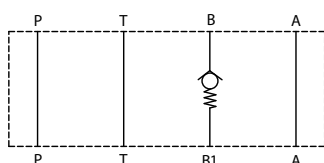



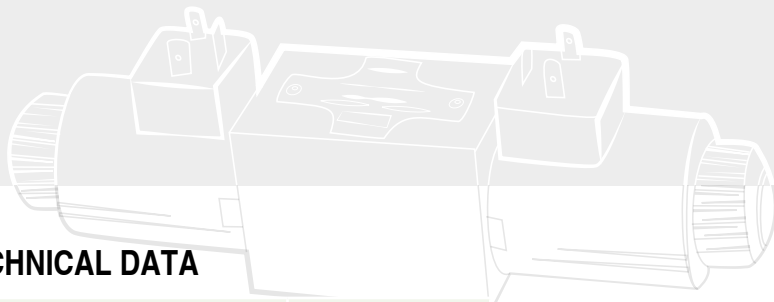

### 3 TECHNICAL DATA

Maximum nominal flow	
Maximum rec. flow rate	60 l/min
Maximum nominal pressure	32 MPa (320 bar)
Pressure drops	see 4
Installation and dimensions	see 5
Mass	approx 1 kg

### 4 TYPICAL DIAGRAMS

Typical  $\Delta p$ -Q curves for valves AM3-CO in standard configuration, with mineral oil at 36 cSt and at 50°C

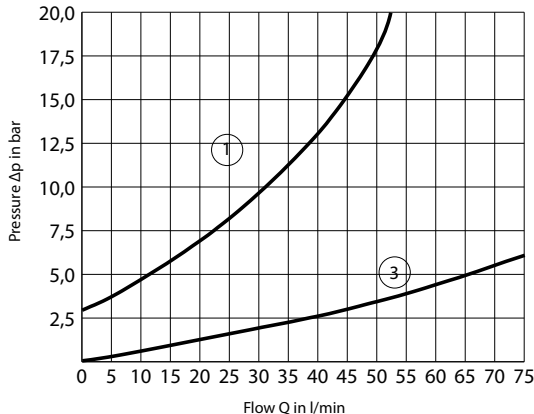

- ① A1->A; P1->P  
B1->B; T->T1
- ③ free channels

### 6 HYDRAULIC FLUIDS

Seals and materials used on standard valves AM3-\* are fully compatible with hydraulic fluids of mineral oil base, upgraded with antifoaming and antioxidantizing agents. The hydraulic fluid must be kept clean and filtered to ISO 4406 class 19/17/14, or better, and used in a recommended viscosity range from 10 cSt to 60 cSt.

### 5 INSTALLATION DIMENSIONS (mm)

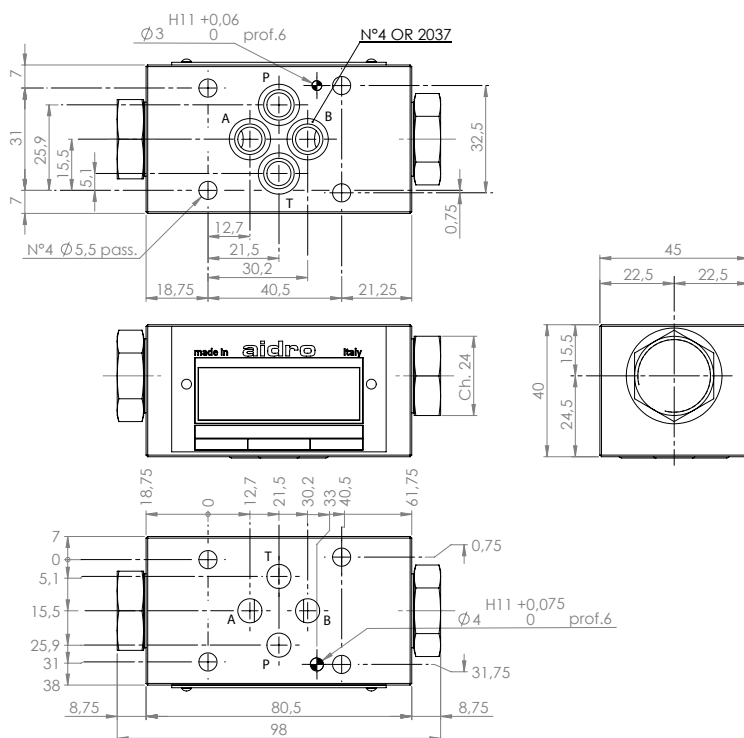

All stackable valves AM3-\* conform with ISO and CETOP specifications for mounting surface dimensions. Valves height 40 mm. Leakage between valve and mounting surface is prevented by the positive compression on their seats of 4 seals of OR type. All valves have on their "mounting" surface a  $\phi$  4 mm cylindrical hole and have on their "seals" surface a  $\phi$  3 mm cylindrical hole, conform with ISO and CETOP norms.

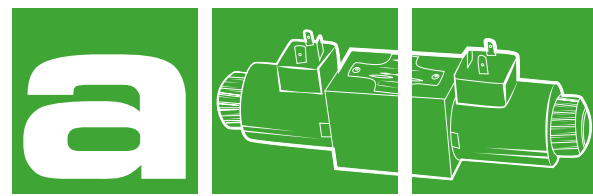

## FLOW CONTROL VALVES

### AM3-CO-\*/25

50 l/min - 32 MPa (320 bar)

#### 1 DESCRIPTION

Direct operated check valve. All the internal part are made with high strenght steel and are machined with accuracy in order to assure the requested tightness. The controlled lines are P, T or PT. The standard surafce treatment of the body is phosphate coated. Plugs are zinc coated.

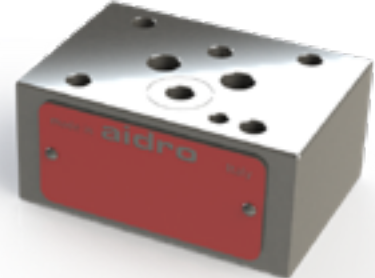

#### 2 ORDERING CODE

(1)	(2)	(3)	(4)	(5)	(6)
AM3	-	CO	-	-	/ 25

(1) AM3: stackable valve CETOP 03 - Pressure 32 MPa (320 bar)

(2) CO: check valve. spring operated

(3) Service lines where the controls operate:

T: checks on T: flow T1->T is blocked, free on A, B and P

P: check on P: flow P-> P1 is blocked, free on A, B and T

PT : check on P and T: P-> P1 and T1-> T are blocked, free on A and B

(4) check valve opening (cracking) pressure (Pm):

no designation (standard): Pm approx 0.2 MPa (2 bar)

(5) Code reserved for option and variants

(6) Design number (progressive) of the valves

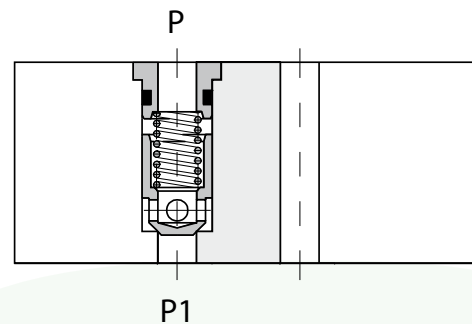
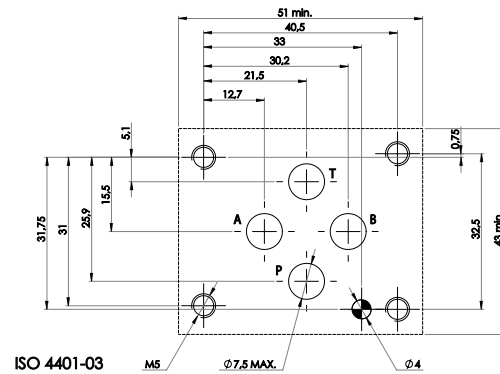

AM3-CO-T-\*\*-\*\*/25

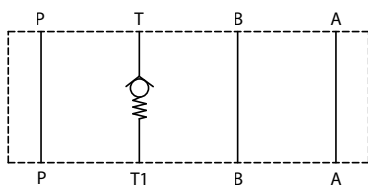

AM3-CO-PT-\*\*-\*\*/25

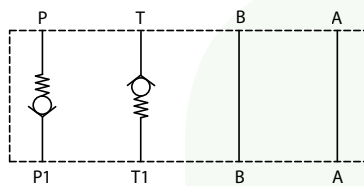

AM3-CO-P-\*\*-\*\*/25

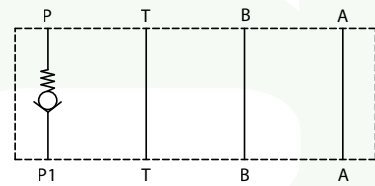

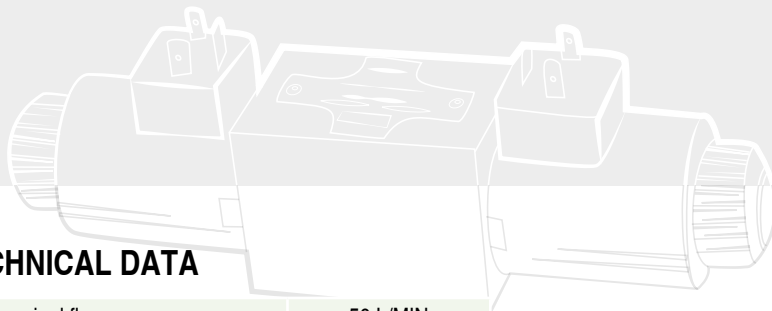

### 3 TECHNICAL DATA

Maximum nominal flow	50 L/MIN
Maximum rec. flow rate	350 l/min
Maximum nominal pressure	32 MPa (320 bar)
Pressure drops	see 4
Installation and dimensions	see 5
Mass	approx 0,9 kg

### 4 TYPICAL DIAGRAMS

Typical  $\Delta p$ -Q curves for valves AM3-CO in standard configuration, with mineral oil at 36 cSt and at 50°C

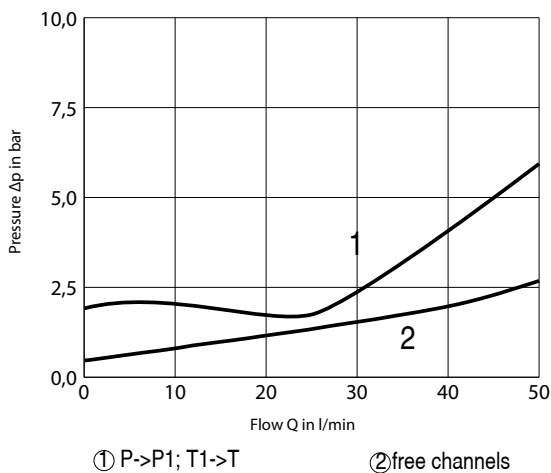

### 5 INSTALLATION DIMENSIONS (mm)

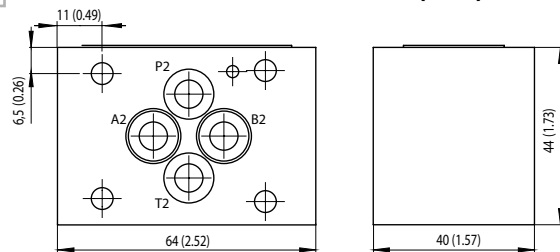

All stackable valves AM3-CO-\*/25 conform with ISO and CETOP specifications for mounting surface dimensions. Valves height 40 mm. Leakage between valve and mounting surface is prevented by the positive compression on their seats of 4 seals. All valves have on their "mounting" surface a  $\phi$  3.4 mm cylindrical hole and have on their "seals" surface a  $\phi$  3 mm cylindrical hole, conform with ISO and CETOP norms.

### 6 HYDRAULIC FLUIDS

Seals and materials used on standard valves AM3-\* are fully compatible with hydraulic fluids of mineral oil base, upgraded with antifoaming and antioxidantizing agents. The hydraulic fluid must be kept clean and filtered to ISO 4406 class 19/17/14, or better, and used in a recommended viscosity range from 10 cSt to 60 cSt.

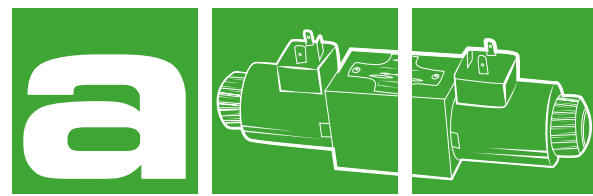

## PILOT OPERATED CHECK VALVES

### AM3-CP-\*

60 l/min - 32 MPa (320 bar)

#### 1 DESCRIPTION

Pilot operated check valve. All the internal part are made with high strenght steel and are machined with accuracy in order to assure the requested tightness. The controlled lines are A, B or AB. The standard surafce treatment of the body is phosphate coated. Plugs are zinc coated.

#### 2 ORDERING CODE

(1)	(2)	(3)	(4)	(5)	(6)
AM3	-	CP	-	-	/ 10

(1) AM3: stackable valve CETOP 03 - Pressure 32 MPa (320 bar)

(2) CP: check valve. spring operated (hydraulically)

(3) Service lines where the controls operate:

AB: pilot operated checks on A and B, fluids flows A -> A1 and B -> B1 and flow A1 -> A (or B1 -> B) is permitted only when B (or A) is pressurized

A : pilot operated check on A; flow A1 -> A is permitted only when B is pressurized

B : pilot operated check on B; flow B1 -> B is permitted only when A is pressurized

(4) check valve opening (cracking) pressure (Pm)

for free flow A->A1 and B->B1:

no designation (standard): Pm approx 0.2 MPa (2 bar)

4: Pm approx 0.4 MPa (4 bar)

(5) Code reserved for option and variants

(6) Design number (progressive) of the valves

#### AM3-CP-A

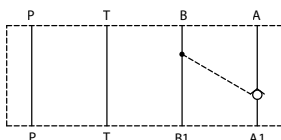

#### AM3-CP-AB

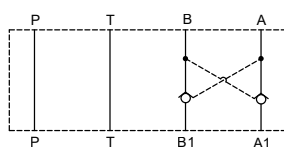

#### AM3-CP-B

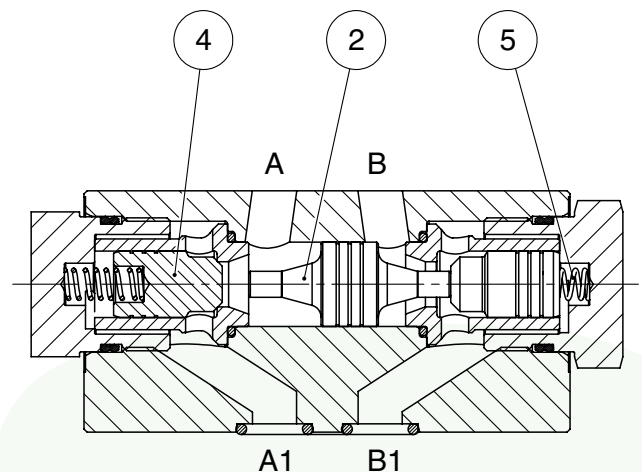
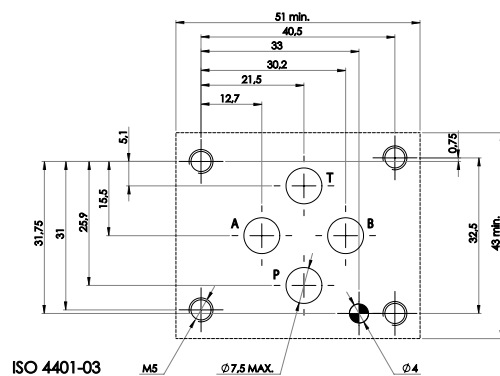
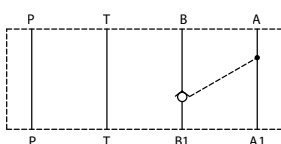

Fluid flows freely on P and T lines;

On service lines A and/or B with p.o. check, fluid flows from A ->A1 (and/ or B ->B1) overcoming the force of spring 5 acting on poppet 4, and fluid is blocked from A1 ->A (and/or B1 -> B). When, by switching the solenoid operated 4-way directional valve, pressure is made available at, for instance, port B fluid flows B -> B1 and the pilot piston 3, shifting from its central position, forces poppet 2, on service line A, to open and permit flow A1 -> A.

### 3 TECHNICAL DATA

Maximum nominal flow		Piloting pressure:
Maximum rec. flow rate	60 l/min	To shift the pilot piston and to open the check in A the piloting pressure must be at B:
Maximum nominal pressure	32 MPa (320 bar)	$P_p = P_b = \frac{P_{a1} + P_m - P_a + P_a}{3,5}$
Pressure drops	see 4	where: P <sub>p</sub> = piloting pressure
Pilot area ration piston/check valve	approx 3,5	P <sub>b</sub> = pressure in B
Installation and dimensions	see 5	P <sub>a</sub> = pressure in A
Mass	approx 1 kg	P <sub>a1</sub> = pressure in A
		P <sub>m</sub> = check valve opening pressure (spring)
		or to open the check in B
		$P_p = P_a = \frac{P_{b1} + P_m - P_b}{3,5} + P_b$

### 4 TYPICAL DIAGRAMS

Typical Δp-Q curves for valves AM3-CP in standard configuration, with mineral oil at 36 cSt and at 50°C

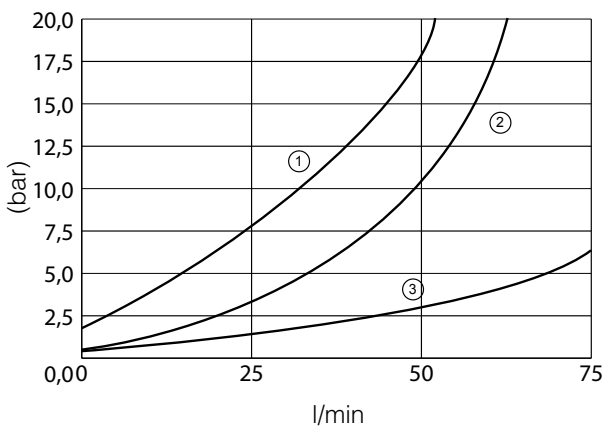

- ① A->A1      ② A1->A      ③ P<->P  
 B->B1      B1->B      T<->T

### 6 HYDRAULIC FLUIDS

Seals and materials used on standard valves AM3 - \* are fully compatible with hydraulic fluids of mineral oil base, upgraded with antifoaming and antioxidantizing agents. The hydraulic fluid must be kept clean and filtered to ISO 4406 class 19/17/14, or better, and used in a recommended viscosity range from 10 cSt to 60 cSt.

### 5 INSTALLATION DIMENSIONS (mm)

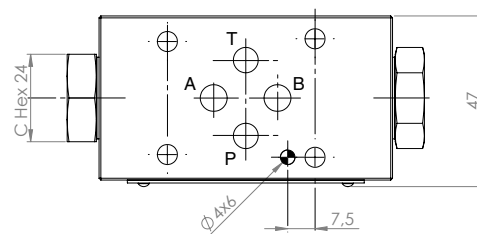
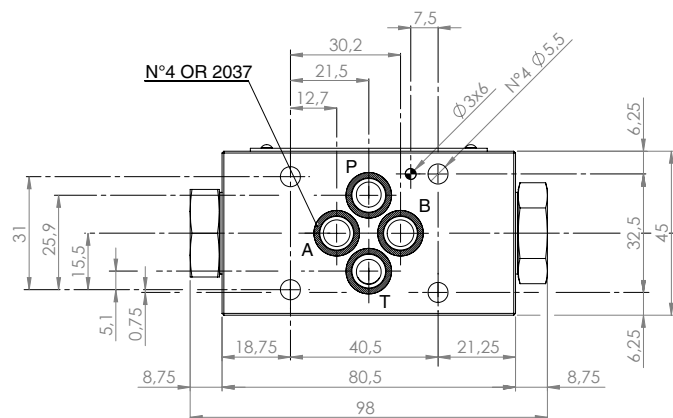

All stackable valves AM3-CP-\*/10 conform with ISO and CETOP specifications for mounting surface dimensions. Valves height 40 mm. Leakage between valve and mounting surface is prevented by the positive compression on their seats of 4 seals. All valves have on their "mounting" surface a ø4 mm cylindrical hole and have on their "seals" surface a ø 3 mm cylindrical hole, conform with ISO and CETOP norms.

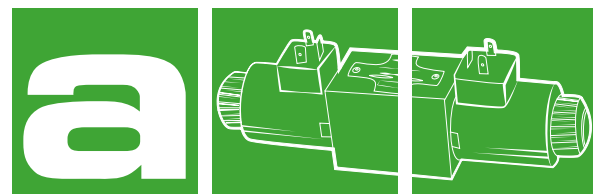

## PRESSURE RELIEF VALVES

### AM3-MO-\*

60 l/min - 32 MPa (320 bar)

#### 1 DESCRIPTION

Stackable pressure relief valve direct operated. The valve is made with a steel body combined with a pressure relief cartridge valve with an anti vibration system.

The body of the valve is phosphate coated. The cartridge valve is zinc coated. The pressure can be set in different pressure ranges.

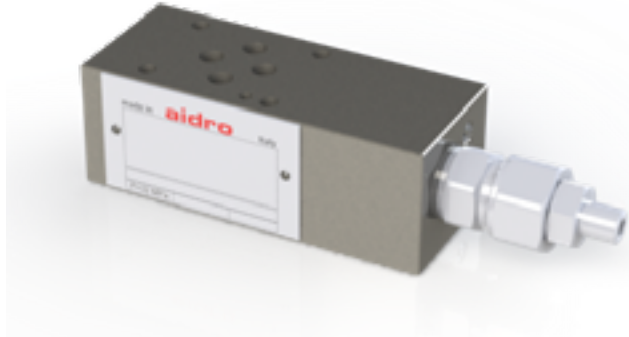

#### 2 ORDERING CODE

(1)	(2)	(3)	(4)	(5)	(6)	(7)
AM3	-	MO	-	-	-	/ 10

(1) AM3: stackable valve CETOP 03 - Pressure 32 MPa (320 bar)

(2) MO: pressure relief, direct acting

(3) Service lines where the controls operate:

P: relief on P and discharge to T

B: relief on B and discharge to T

BA: independent relief on B and on A and discharge to T

(4) Pressure adjustment ranges:

10: from 2,5 MPa to 12,5 MPa (from 25 to 125 bar)

20: from 4 MPa to 25 MPa (from 40 to 250 bar)

32: from 10 MPa to 32MPa (from 100 to 320 bar)

(5) Pressure adjustment range for relief on A

(only for models AM3-MO-BA) see 4

(6) Code reserved for more options and variants

(7) Design number (progressive) of the valves

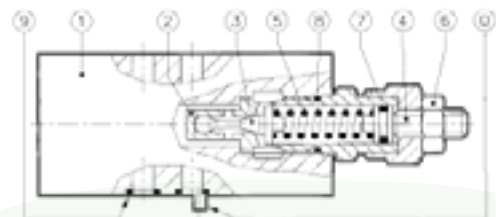
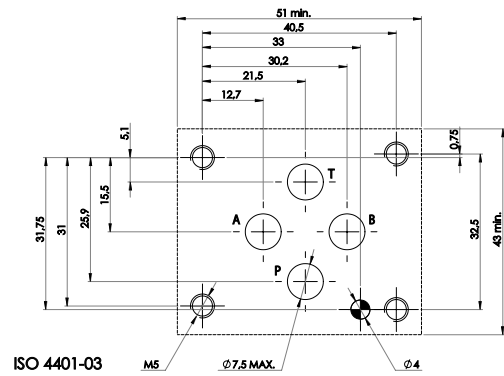

AM3-MO-P



AM3-MO-B

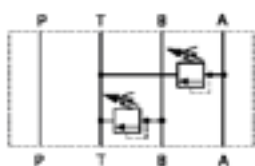

AM3-MO-BA

## 3 TECHNICAL DATA

Maximum nominal flow		Adjustment of the relief pressure:
Maximum rec. flow rate on free lines	1 dm <sup>3</sup> /s (60 l/min)	Relief pressure is reached when the axial hydraulic forces on piston 3 equal the force of spring 5; the value of the relief pressure can be therefore changed, within the limits of the chosen adjustment range, by changing the compression of spring 5. To increase the relief pressure, turn clock wise the adjustment screw 4, after having unlocked ist nut 6. For each pressure adjustment range, the pressure gradient is approx:
On protected lines	0,5 dm <sup>3</sup> /s approx 32 l/min	10: 1,6 MPa/mm (24 bar/turn)
Maximum nominal pressure	32 MPa (320 bar)	20: 3,2 MPa/mm (48 bar/turn)
Pressure relief curves	see 4	32: 5 MPa/mm (75 bar/turn)
Installation and dimensions	see 5	When the required level of pressure is reached, lock the nut 6.
Masses		
AM3-MO-P or B	approx 1,7 kg	
AM3-MO-BA	approx 2,3 kg	

## 4 TYPICAL DIAGRAMS

Typical  $\Delta p$ -Q curves for valves AM3-MO-\* in standard configuration, with mineral oil at 36 cSt and at 50°C

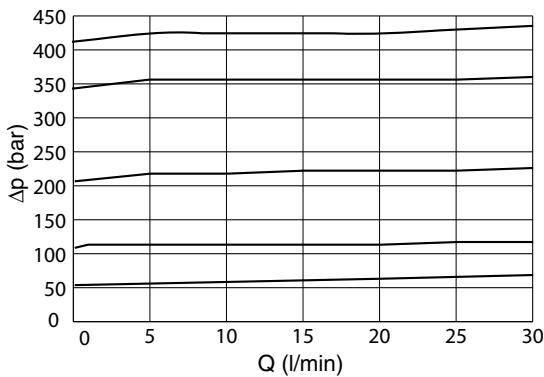

## 6 HYDRAULIC FLUIDS

Seals and materials used on standard valves AM3 - \* are fully compatible with hydraulic fluids of mineral oil base, upgraded with antifoaming and antioxidantizing agents. The hydraulic fluid must be kept clean and filtered to ISO 4406 class 19/17/14, or better, and used in a recommended viscosity range from 10 cSt to 60 cSt.

All stackable valves AM3-\* conform with ISO and CETOP specifications for mounting surface dimensions. Valves height 40 mm. Leakage between valve and mounting surface is prevented by the positive compression on their seats of 4 seals of OR type. All valves have on their "mounting" surface a  $\phi 4$  mm cylindrical hole and have on their "seals" surface a  $\phi 3$  mm locating pin, to conform with the norms. In case of necessity, the pin can be easily removed.

## 5 INSTALLATION DIMENSIONS (mm)

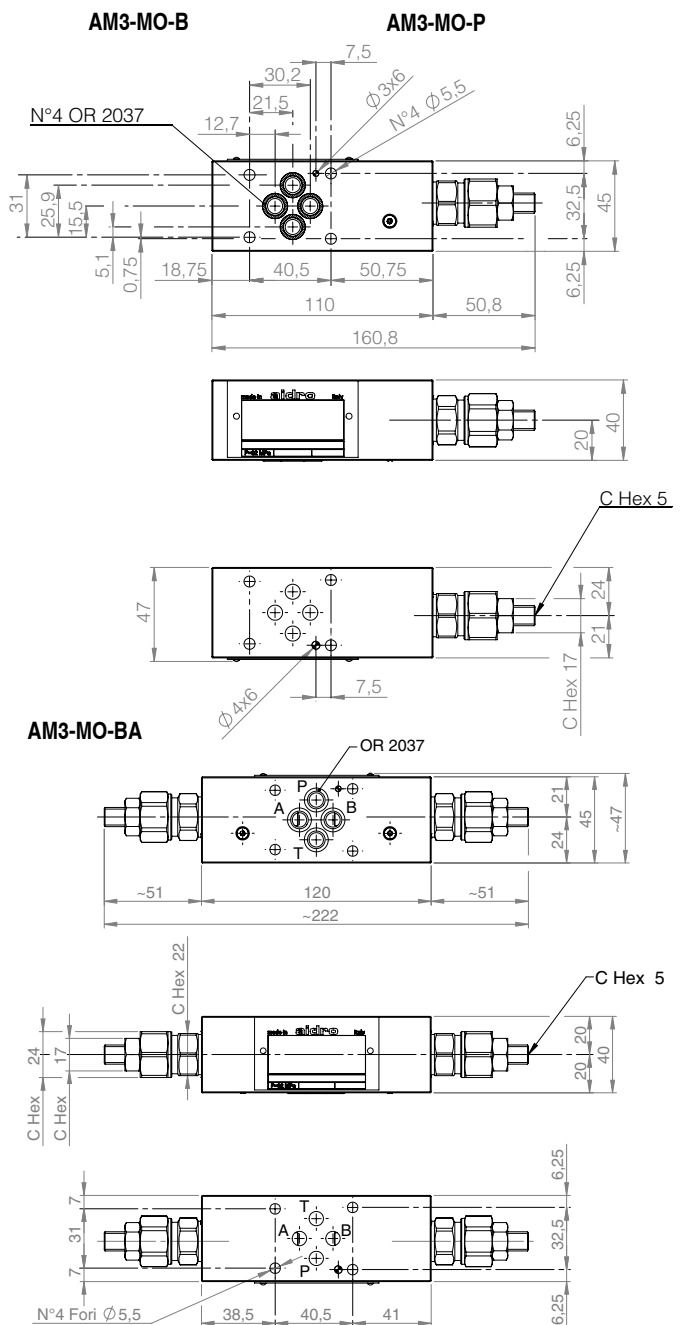

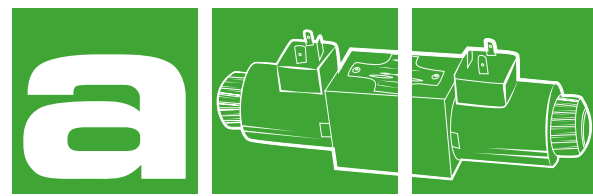

## STACKABLE VALVE RELIEF VALVE AND BYPASS

### AM3-M\*-EV\*

60 l/min - 32 MPa (320 bar)

#### 1 DESCRIPTION

The module acts as relief valve and solenoid by-pass valve with high performances and full CETOP 03 flows. The Pressure relief valve is a 7/8" 14 UNF valve direct operated. Optionally can be installed the pilot operated relief valve which assure a constant behavior at different flow rates. The by-pass valve is a special 3/4" 16 UNF valve with bigger nose, able to manage 50 l/min with low pressure drops.



#### 2 ORDERING CODE

(1)	(2)	(3)	(4)	(5)	(6)	(7)
AM3	-	-	-	-	-	/ 10

(1) AM3:stackable valve CETOP 03 - Pressure 32 MPa (320 bar)

(2) Pressure relief valve:  
 MO: Pressure relief valve direct operated  
 MP: Pressure relief valve pilot operated

(3) EV: bypass valve pilot operated  
 EVC: bypass valve normally closed  
 EVO: bypass valve normally open

(4) Code reserved for options and variants  
 04:emergency push button

(5) Electric voltage and solenoid coils:  
 012C: coils for V12DC  
 024C: coils for V24DC  
 220R: coils for V220-230 RAC  
 230/50: coils for V230/50 AC

(6) Coil connection:  
 no designation: DIN 43650-A ISO 4400  
 AMP: Amp Junior Timer

(7) Design number (progressive) of the valves.

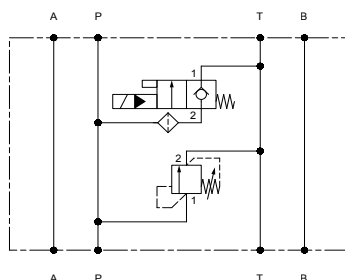
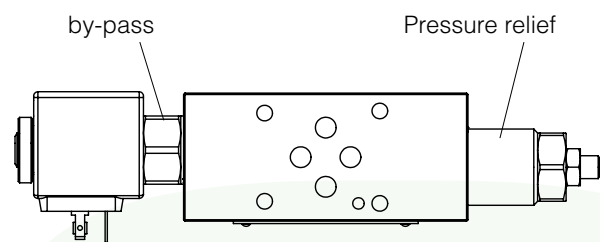
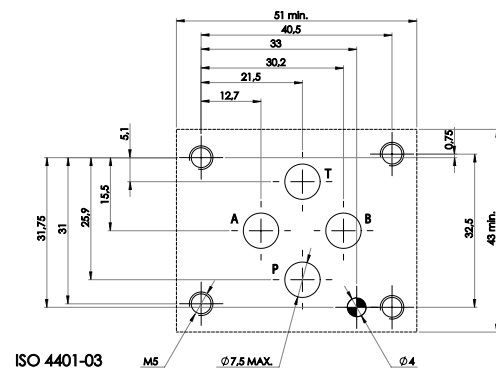

Example AM3-MO-EVC.\*



### 3 TECHNICAL DATA

Maximum nominal flow	50 l/min	<b>Electric characteristics:</b> Valve type AM3-M*EV are operated by solenoid that are energized : • directly from a D.C. voltage supply V 12 DC = 012C V 24 DC = 024C • by the use of coils that incorporate a full wave bridge rectifier, from A.C. voltage supply : V 220/50 - V 230/60 = 230/50 All connectors must conform to ISO 4400 (DIN 43650) and electric circuitry must be able to carry the following rated current values : V 12 DC = 1,5 A V 24 DC = 0,8 A      V 230/50 = 0,14 A Permissible supply voltage variation : ± 10 %
Maximum rec. flow rate on free lines	60 l/min	
Protection to DIN 40050	IP 65	
Maximum nominal pressure	32 MPa (320 bar)	
Pressure drops	see [4]	
Installation and dimensions	see [5]	
Valve body	steel	
Mass	1,5 kg	

### 4 TYPICAL DIAGRAMS

Typical P-Q curves for valves AM3-M\*EV in standard configuration, with mineral oil at  $\nu=32 \text{ mm}^2/\text{s}$  and at  $T=40^\circ\text{C}$ .

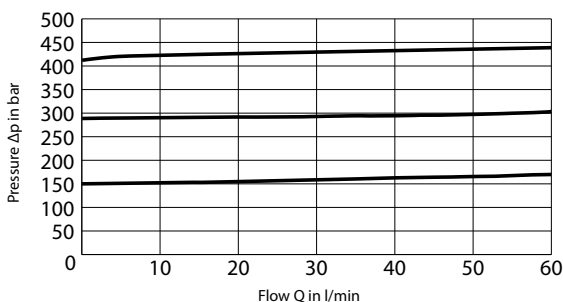
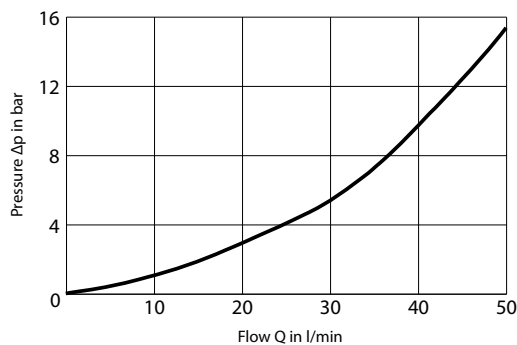

### 5 INSTALLATION DIMENSIONS (mm)

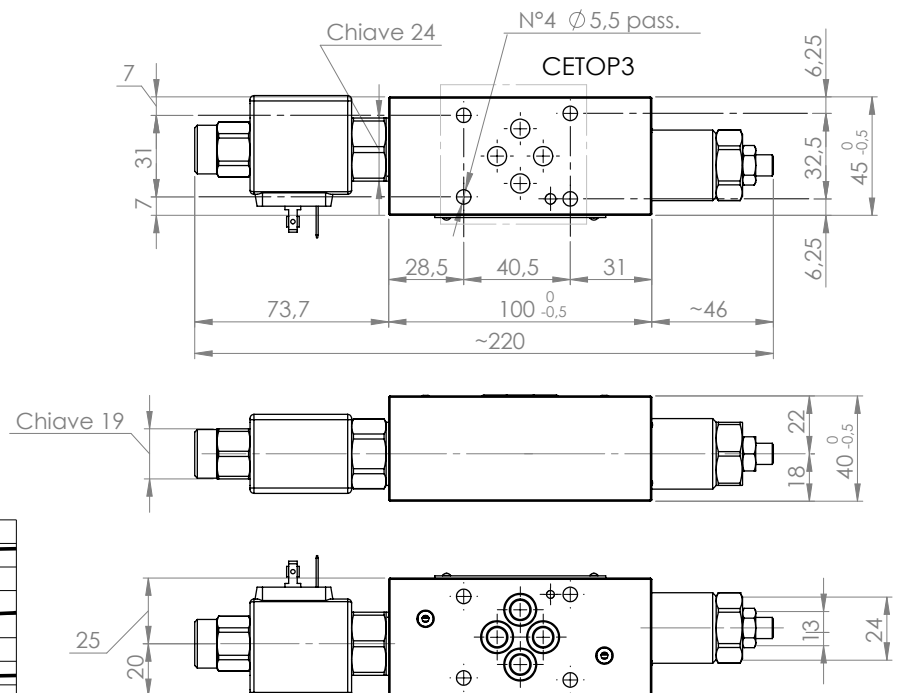

Example AM3-MP-EVC

### 6 HYDRAULIC FLUIDS

Seals and materials used on standard valves AM3-\* are fully compatible with hydraulic fluids of mineral base, upgraded with antifoaming and anti oxidizing agents. The hydraulic fluid must be kept clean and filtered to ISO 4406 class 19/17/14, or better, and used in a recommended viscosity range from 10 cSt to 60 cSt.

When assembled to its mounting plate, valve AM3-M\*EV must be fastened with 4 bolts M5x45 (or M5x\*\* according to the number of modules) tightened at 8 Nm torque. Leakage between valve and mounting surface is prevented by the positive compression on their seats of 4 seals of O-Ring type 2037.

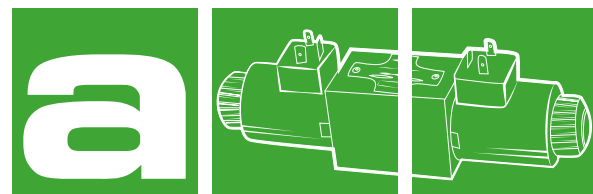

## PRESSURE RELIEF VALVES

### AM3-MP-\*

60 l/min - 32 MPa (320 bar)

#### 1 DESCRIPTION

Stackable pressure relief valve pilot operated. The valve is made with a steel body combined with a pressure relief cartridge valve pilot operated for a stable pressure control.

The body of the valve is phosphate coated. The cartridge valve is zinc coated. The pressure can be set in different pressure ranges.

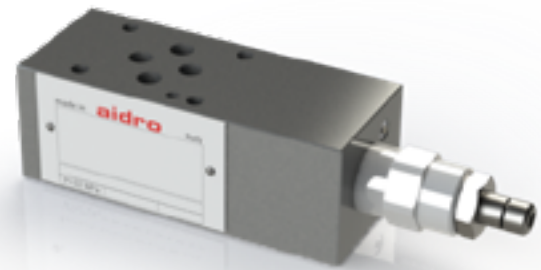

#### 2 ORDERING CODE

(1)	(2)	(3)	(4)	(5)	(6)	(7)
AM3	- MP	- /	-	-	- /	10

(1) AM3: stackable valve CETOP 03 - Pressure 32 MPa (320 bar)

(2) MP: pressure relief- pilot operated

(3) Service lines where the controls operate:

P: relief on P and discharge to T

B: relief on B and discharge to T

BA: independent relief on B and on A and discharge to T

AB: relief on A and B with crossed discharge

(4) Pressure adjustment ranges:

6,3 : from 1 to 7 MPa (from 10 to 70 bar)

12,5: from 1 to 14 MPa (from 10 to 140 bar)

20: from 2 to 21 MPa (from 20 to 210 bar)

32: from 2 to 32 MPa (from 20 to 320 bar)

(5) Pressure adjustment range for relief on A

(only for models AM3-MP-BA) or for relief on B for models AM3-MP-AB

(6) Code reserved for more options and variants

(6) Design number (progressive) of the valves

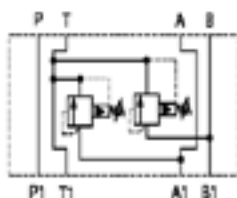
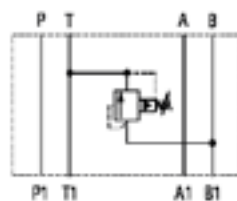
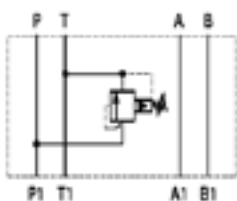
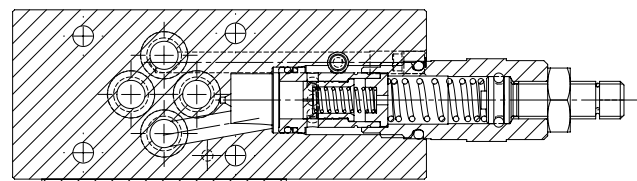
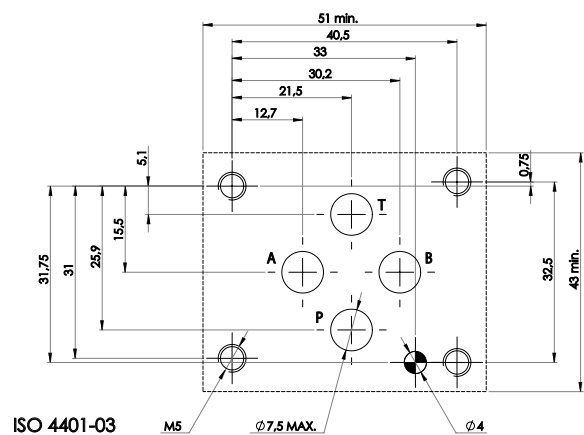

### 3 TECHNICAL DATA

Maximum nominal flow		Adjustment of the relief pressure:
Maximum rec. flow rate	1 dm <sup>3</sup> /s (60 l/min)	Relief pressure is reached when the axial hydraulic forces on piston 3 equal the force of spring; the value of the relief pressure can be therefore changed, within the limits of the chosen adjustment range, by changing the compression of spring. To increase the relief pressure, turn clock wise the adjustment screw CH5, after having unlocked ist nut CH17 mm.
Maximum nominal pressure	32 MPa (320 bar)	For each pressure adjustment range, the pressure gradient is approx:
Pressure relief curves	see 4	6,3: 2 MPa/turn (24 bar/turn)
Installation and dimensions	see 5	12,5: 4 MPa/turn (40 bar/turn)
Masses		20: 6,3 MPa/turn (630 bar/turn)
AM3-MP-P	approx 1,7 kg	32: 10 MPa/turn (100 bar/turn)
AM3-MP-BA	approx 2,3 kg	When the required level of pressure is reached, lock the nut CH17mm.

### 4 TYPICAL DIAGRAMS

Typical curves for valves AM3-MP in standard configuration, with mineral oil at 36 cSt and at 50°C

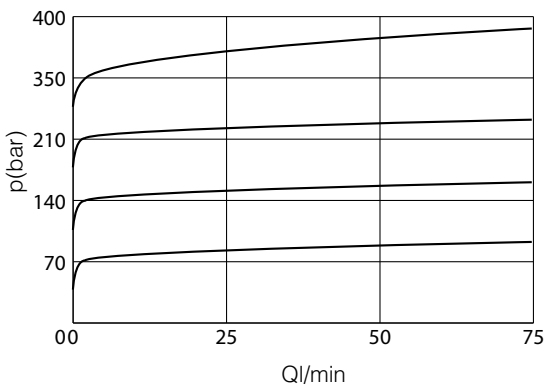

### 5 INSTALLATION DIMENSIONS (mm)

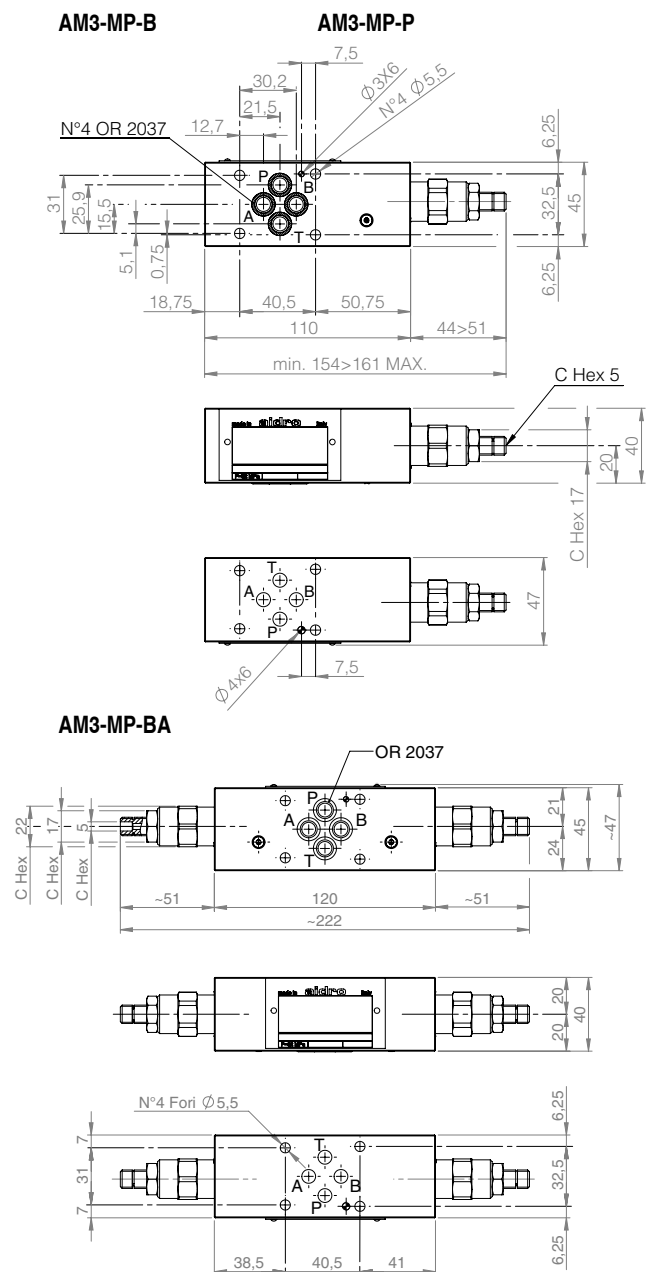

### 6 HYDRAULIC FLUIDS

Seals and materials used on standard valves AM3-\* are fully compatible with hydraulic fluids of mineral oil base, upgraded with antifoaming and antioxidantizing agents. The hydraulic fluid must be kept clean and filtered to ISO 4406 class 19/17/14, or better, and used in a recommended viscosity range from 10 cSt to 60 cSt.

All stackable valves AM3-\* conform with ISO and CETOP specifications for mounting surface dimensions and for valves height 40 mm. Leakage between valve and mounting surface is prevented by the positive compression on their seats of 4 seals type OR 2037.

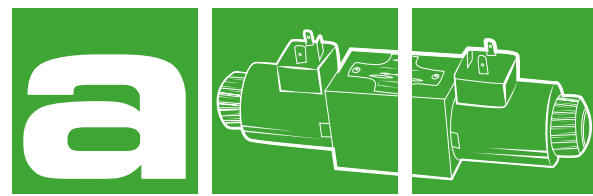

## PRESSURE REDUCING VALVES

### AM3-RO-\*

60 l/min - 32 MPa (320 bar)

#### 1 DESCRIPTION

Stackable pressure reducing valve direct operated. The valve is made with a steel body combined with a pressure relief valve integrated in the body. The body of the valve is phosphate coated. The cartridge valve is zinc coated.

The pressure can be set in different pressure ranges.



#### 2 ORDERING CODE

(1)	(2)	(3)	(4)	(5)	(6)
AM3	- RO	-	/	-	/ 10

(1) AM3: stackable valve CETOP 03 - Pressure 32 MPa (320 bar)

(2) RO: pressure reducing, direct operated- 3 way valve

(3) Service lines where the controls operate:

P: control on P with 3<sup>a</sup> way and drain to T line

A: control on A with 3<sup>a</sup> way and drain to T line

B: control on B with 3<sup>a</sup> way and drain to T line

(4) Pressure adjustment ranges:

32 : from 0,3 to 3,5 MPa (from 3 to 35 bar)

6,3: from 1 to 7 MPa (from 10 to 70 bar)

12,5: from 3 to 14 MPa (from 30 to 140 bar)

25: from 6 to 28 MPa (from 60 to 280 bar)

(5) Code reserved for more options and variants

V= adjustment hand knob

(6) Design number (progressive) of the valves

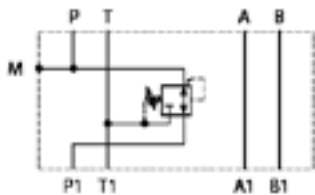
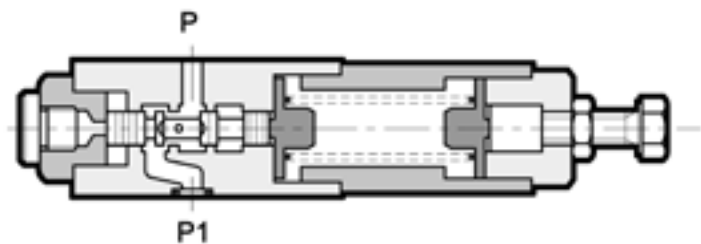
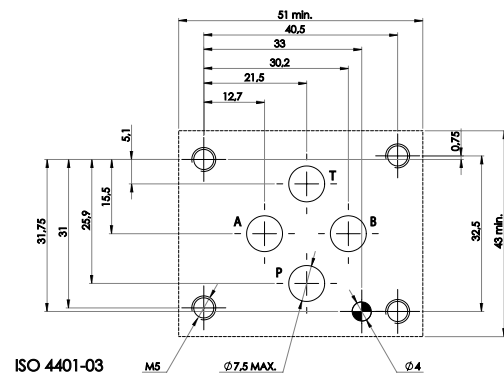

AM3-RO-P

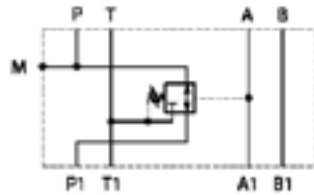

AM3-RO-A

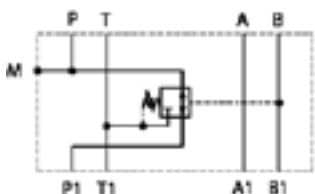

AM3-RO-B

All valves AM3-RO-\* are 3 way, direct operated: If the pressure in the regulated chamber overcomes the value of the adjusted, reduced pressure, the valve discharges to T (at pressure value higher then the reduced pressure- see diagrams) thus acting as safety or relief valve.

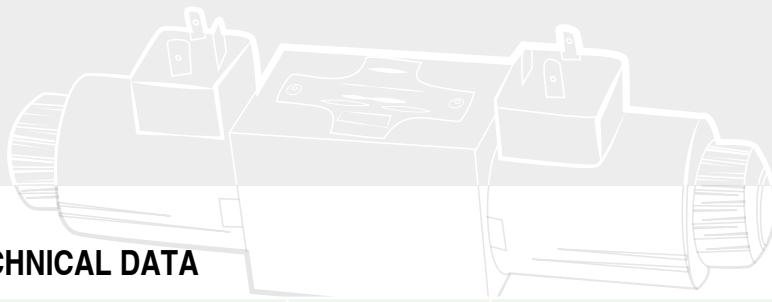

### 3 TECHNICAL DATA

Maximum rec. flow rate on free lines	1 d m <sup>3</sup> /s (60 l/min)	Adjustment of the relief pressure: Reduced pressure is obtained by throttling the flow on spool which is balanced, on one side, by the reduced pressure and, on the other side by the positioning spring. The value of the reduced pressure is changed by changing the compression of spring. To increase the value of the reduced pressure, turn clockwise the handknob or screw 3 by acting on ex. CH17 mm, after having unlocked ist nut. when the required level of pressure is reached, lock the nut.
on controlled lines	0,66 dn <sup>3</sup> /s (40 l/min)	
Maximum nominal pressure	32 MPa (320 bar)	For each pressure adjustment range, the pressure gradient is approx: 3,2: 0,7 MPa/turn (7 bar/turn) 6,3: 1,4 MPa/turn (14 bar/turn) 12,5: 2,5 MPa/turn (25 bar/turn) 25: 5 MPa/turn (50 bar/turn)
Maximum pressure on T	10 MPa (100 bar)	
Max drain	<1,2 cm <sup>3</sup> /s (0,07 l/min)	
Pressure curves	see 4	
Installation and dimensions	see 5	
Masses		
AM3-MP-BA	approx 2,3 kg	

### 4 TYPICAL DIAGRAMS

Typical curves for valves AM3-RO in standard configuration, with mineral oil at 36 cSt and at 50°C

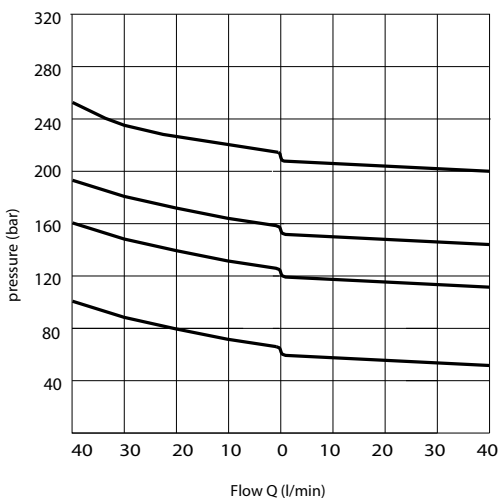

### 5 INSTALLATION DIMENSIONS (mm)

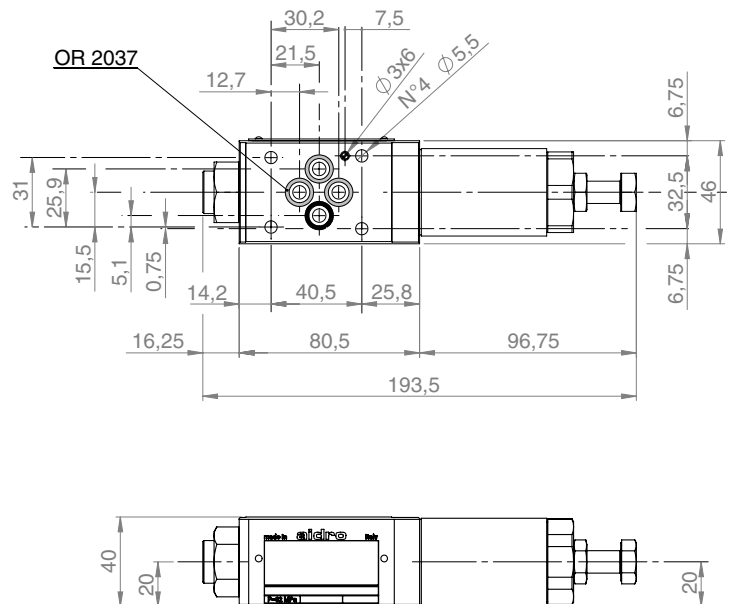

### 6 HYDRAULIC FLUIDS

Seals and materials used on standard valves AM3-\* are fully compatible with hydraulic fluids of mineral oil base, upgraded with antifoaming and antioxidantizing agents. The hydraulic fluid must be kept clean and filtered to ISO 406 class 19/17/14, or better, and used in a recom ended viscosity range from 10 cSt to 60 cSt.

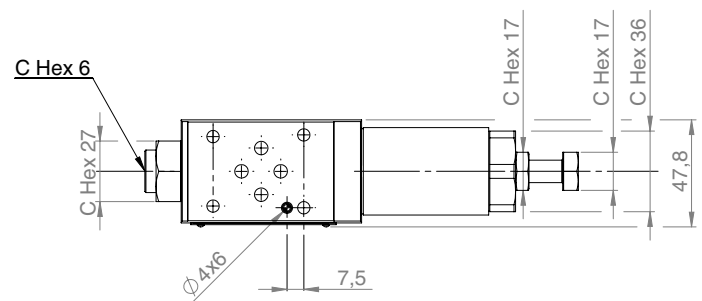

All stackable valves AM-RO- \* conform with ISO and CETOP specifications for mounting surface dimensions and for valves height 40 mm. Leakage between valve and mounting surface is prevented by the positive compression on their seats of 4 seals type OR 2037.

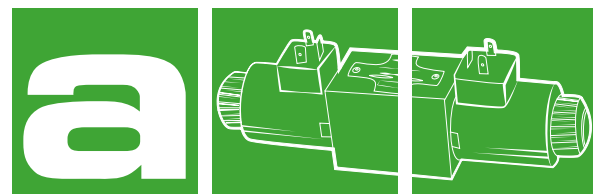

## DIRECT ACTING, PRESSURE REDUCING VALVES ON B LINE

### AM3-RO-BC/6,3

60 l/min - 32 MPa (320 bar)

#### 1 DESCRIPTION

Stackable pressure reducing valve direct operated. The valve is made with a steel body combined with a pressure relief cartridge valve and with a check valve. The body of the valve is in aluminium. The cartridge valve is zinc coated. The pressure can be set in different pressure ranges.

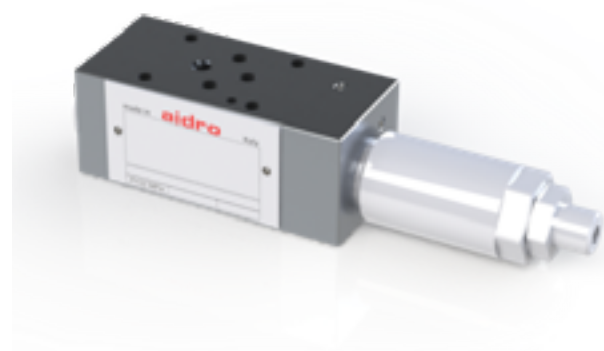

#### 2 ORDERING CODE

(1)	(2)	(3)	(4)
AM3	- RO	- BC	/ 6,3

- (1) AM3: stackable valve CETOP 03
- (2) RO: pressure reducing, direct operated- 3 way valve
- (3) BC: line where the control operates: B with check valve
- (4) 6,3: controlled pressure adjustment ranges (up to 6,3 MPa)

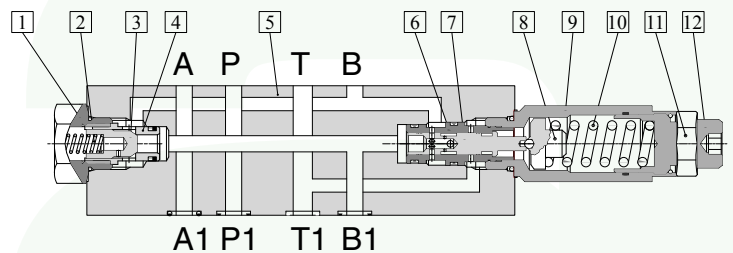
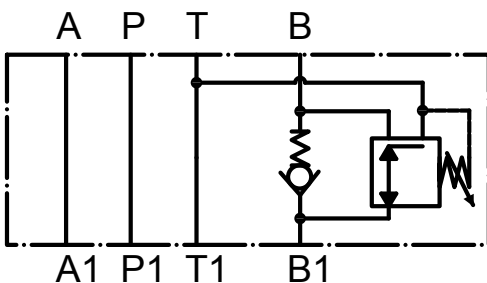
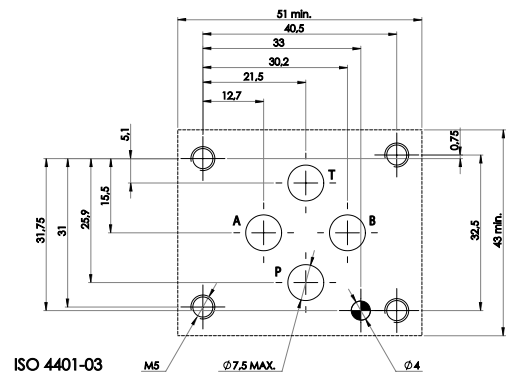

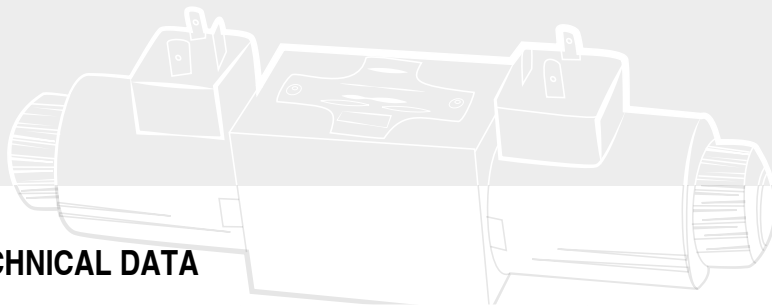

### 3 TECHNICAL DATA

Maximum nominal pressure	32 MPa (320 bar)	Adjustment of the regulated pressure: The pressure in B1 line can be set by acting on the adjustment element 12 (screw with internal hexagon 6 mm), after having unlocked its retaining nut 11. Turn clockwise to increase pressure at B1 port.
Maximum pressure on B line	15 MPa (150 bar)	
Maximum rec. flow on B line	20 l/min	
Maximum rec. flow on free lines	60 l/min	
Regulated pressure on B1 line	up to 6,3 MPa (63 bar)	

### 4 INSTALLATION DIMENSIONS (mm)

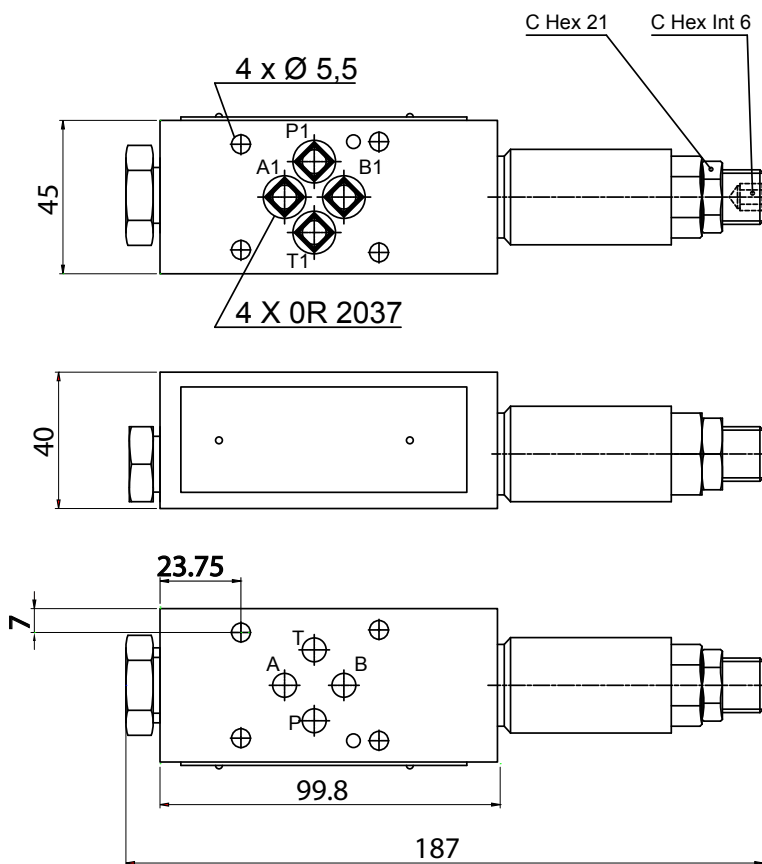

### 5 HYDRAULIC FLUIDS

Seals and materials used on standard valve AM3\* are fully compatible with hydraulic fluids of mineral oil base, upgraded with antifoaming and antioxidantizing agents. The hydraulic fluid must be kept clean and filtered to ISO 4406 class 19/17/14, or better, and used in a recommended viscosity range from 10 cSt to 60 cSt.

All stackable valves AM3- \* conform with ISO and CETOP specifications for mounting surface dimensions. Leakage between valve and mounting surface is prevented by the positive compression on their seats of 4 seals of OR type.

## PRESSURE REDUCING MODULAR VALVES

### AM3-RP-\*

60 l/min - 32 MPa (320 bar)

#### 1 DESCRIPTION

Stackable pressure reducing valve pilot operated. The valve is made with a steel body combined with a pressure relief valve. The body of the valve is phosphate coated. The cartridge valve is zinc coated. The pressure can be set in different pressure ranges.



#### 2 ORDERING CODE

(1)	(2)	(3)	(4)	(5)	(6)
AM3	- RP	-	/	-	/ 10

(1) AM3: stackable valve CETOP 03 - Pressure 32 MPa (320 bar)

(2) RP: pressure reducing, pilot operated- 3 way valve

(3) Service lines where the controls operate:  
 P: control on P with 3<sup>a</sup> way and drain to T line  
 AC: control on A with check valve

(4) Pressure adjustment ranges:  
 6,3: from 0,5 to 7MPa (from 5 to 70bar)  
 20: from 1 to 14MPa (from 30 to 140bar)

(5) Code reserved for more options and variants  
 V= adjustment hand knob

(6) Design number (progressive) of the valves

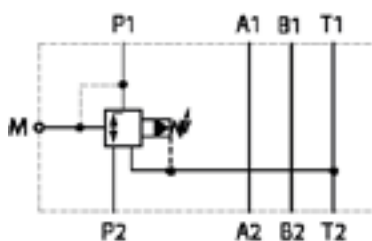
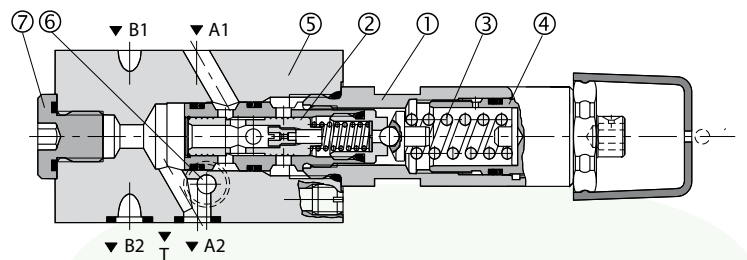
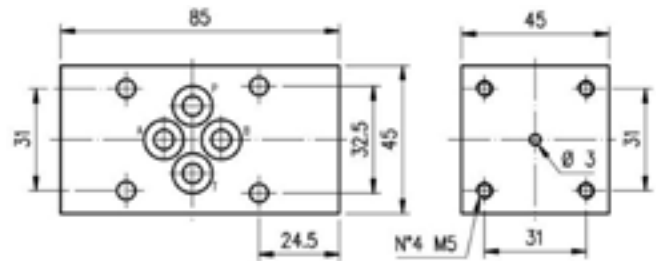

AM3-RP-P

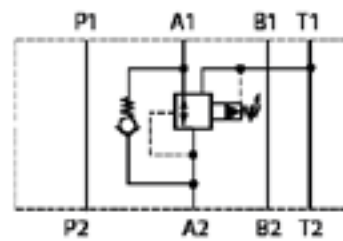

AM3-RP-AC



## 3 TECHNICAL DATA

Maximum rec. flow rate on free lines	1 dm <sup>3</sup> /s (60 l/min)	Adjustment of the pressure: Reduced pressure is obtained by throttling the flow on spool 2 which is balanced, on one side, by the reduced pressure and, on the other side by the positioning spring and by the pilot pressure. Pilot pressure is established by the action on spring 3 on the pilot valve 7. The value of the reduced pressure is changed by changing the compression of spring 3. To increase the value of the reduced pressure, turn clockwise the handknob or screw by acting on ex. CH10mm, after having unlocked ist nut 8 (CH 26 mm). When the required level of pressure is reached, lock the nut 8.
on controlled lines	0,66 dm <sup>3</sup> /s (40 l/min)	
Maximum nominal pressure	32 MPa (320 bar)	
Maximum pressure on T	10 MPa (100 bar)	
Pilot flow rate	4 cm <sup>3</sup> /s (0,24 l/min)	
Pressure curves	see 4	
Installation and dimensions	see 5	
Masses		
AM3-RP-P	approx 1,1 kg	
AM3-RP-AC	approx 1,45 kg	

## 4 TYPICAL DIAGRAMS

Typical curves for valves AM3-RP in standard configuration, with mineral oil at 36 cSt and at 50°C

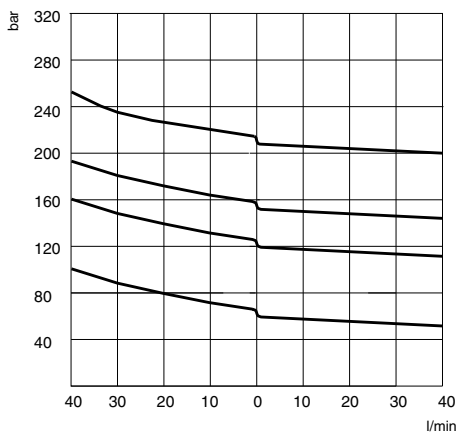

All valves AM3-RP-\* are 3 way, direct operated:

If the pressure in the regulated chamber overcomes the value of the adjusted, reduced pressure, the valve discharges to T (at pressure value higher then the reduced pressure- see diagrams) thus acting as safety or relief valve. Valves reducing pressure anA or B lines are with integral check valve 9 (types AM3-RP-AC or BC) and they allow reverse flow to port A or B of the solenoid valve.

## 5 INSTALLATION DIMENSIONS (mm)

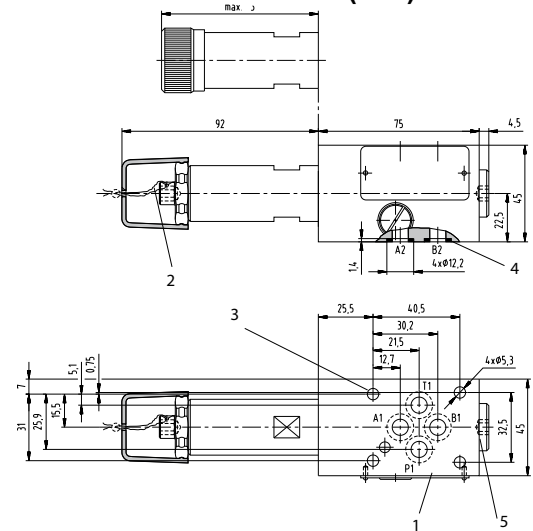

Model AM3-RP-P

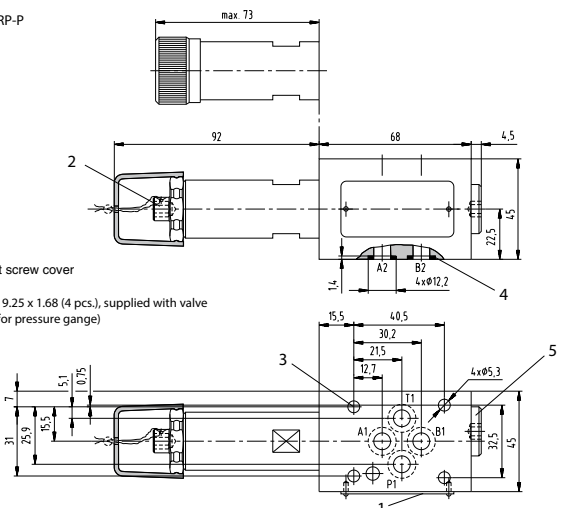

- 1 Label
- 2 Adjustment screw cover
- 3
- 4 Square ring 9.25 x 1.68 (4 pcs.), supplied with valve
- 5 Plug G1/4 (for pressure gauge)

All stackable valves AM-RP-\* conform with ISO and CETOP specifications for mounting surface dimensions and for valves height 45 mm. Leakage between valve and mounting surface is prevented by the positive compression on their seats of 4 seals type OR 2037.

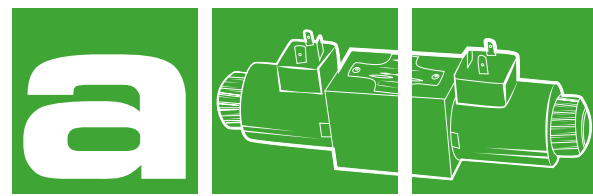

## MODULAR VALVES 3-WAY PRESSURE COMPENSATOR WITH LOAD SENSING

### AM3-LS-P3

40 l/min - 32 MPa (320 bar)

#### 1 DESCRIPTION

3 way pressure compensator normally used together with proportional directional valves in order to control the flow independently from pressure variations. The selection of the piloting pressure is made by the use of the integrated shuttle valve which controls the ports A and B.



#### 2 ORDERING CODE

(1)	(2)	(3)	(4)	(5)	(6)	(7)
AM3	-	LS	-	P	3	/ / 10

- (1) AM3: 4-way modular valve CETOP 03
- (2) LS: pressure compensator with "Load sensing" function and adjustable QP
- (3) P: control on P line
- (4) 3: 3-way compensator with unloading of exceed pressure in T
- (5) Code reserved for more options and variants  
V= adjustment knob
- (6) Standard version- control in A and B  
A-control in A  
B- control in B
- (7) Design number (progressive) of the valves

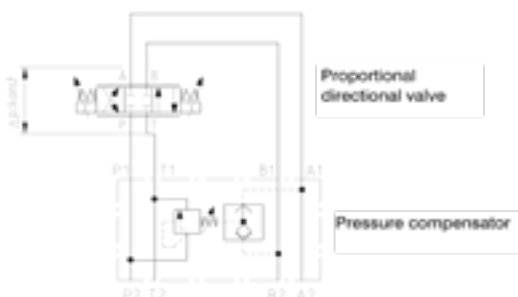
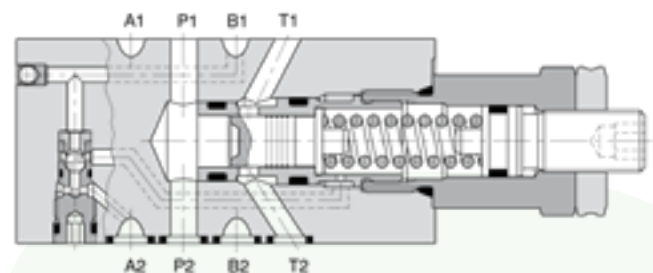
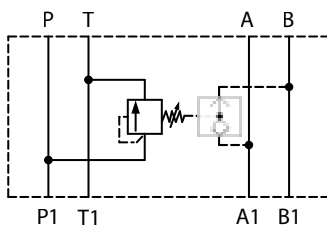
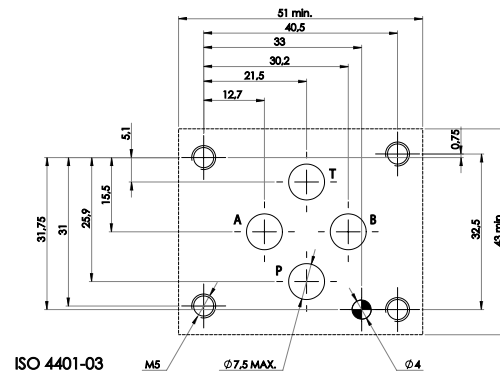

The valve is a 3-way pressure compensator, with direct action, modular version with the mounting surface correspondent to CETOP and ISO standards. It's function is a maintenance of pressure drops DP characteristics between the P and A or B. Normally used in a combination with directional proportional valves in order to provide control of the flow independently from the variations of the pressure. The selection of the pressure of the pilot on A and B lines is automatically executed by a check valve incorporated in the compensator

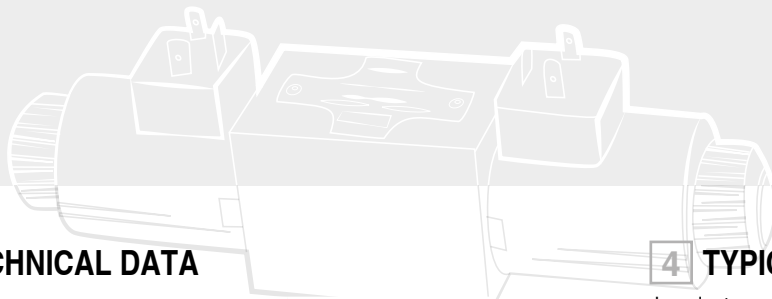

### 3 TECHNICAL DATA

Maximum rec. flow rate	0,66 dm <sup>3</sup> /s (40 l/min)
Maximum nominal pressure	32 MPa (320 bar)
Setting calibration $\Delta p$	adjustable from 0,5 to 4 MPa (5-40 bar)
Installation and dimensions	see 5
Mass	1kg

### 4 TYPICAL DIAGRAMS

In order to ensure the correct control function the outside pressure difference has to be increased when increasing the flow resistance due to a flow rate increase

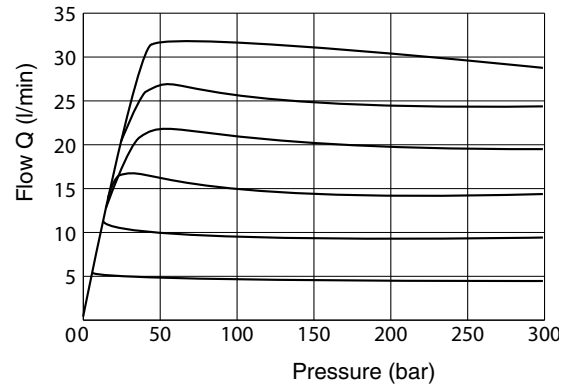

### 5 INSTALLATION DIMENSIONS (mm)

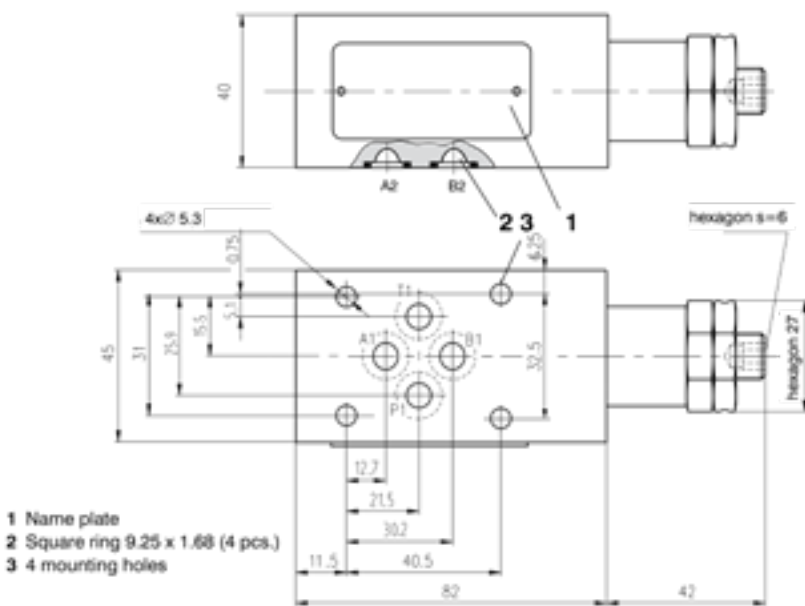

The valves AM3-LS-P3\* conform to ISO and CETOP standards with regards to mounting surface. Height of stacking is 40 mm. The sealing between the valve and mounting surface is insured by 4 seals type OR 2037 or Quad-ring.

### 6 CALIBRATION OF $\Delta P$

Efficient calibration of DP of the valve AM3-LSP3 is fundamental procedure for setting range of flow to utensils. Increasing DP, according to the non-linear law, increases also value of compensated flows, that pass through regulating organ (throttle with variable light) independently of working pressure of the system. For example in a system illustrated in Typical applications p.1, composed of AM3-LSP3 and proportional valve HD3-PS-3RC-xx (see table HD3-PS), with DP of the valve of 1 MPa (10 bar), the flow to the actuator will be between 0 and 16 l/min, with DP of the valve of 3 MPa (30 bar), the flow to the actuator will be between 0 and 28 l/min (always independently of working pressure of the system). Therefore it is essential in order to optimize functioning of the system to regulate DP of the compensator. This can be done by acting with CH6 mm on the pin regulator after locking nut has been loosen to CH27 mm: it is suggested to loosen the spring completely by turning the pin with thread pitch 1,25 mm anticlockwise until full mechanical stop.

Thereafter by turning clockwise you obtain:

DP = 0,4 MPa (4 bar) run 2,5 mm\* (2 turns)

DP = 1,2 MPa (12 bar) run 3,75 mm\* (3 turns)

DP = 2,1 MPa (21 bar) run 5 mm\* (4 turns)

DP = 3 MPa (30 bar) run 6,25 mm\* (5 turns)

DP = 3,9 MPa (39 bar) run 7,5 mm\* (6 turns)

\* including one initial "dead" turn of appr. 2 mm (1,5 turns).

After desired calibration was done, lock with the fixing nut 1 to CH27 mm.

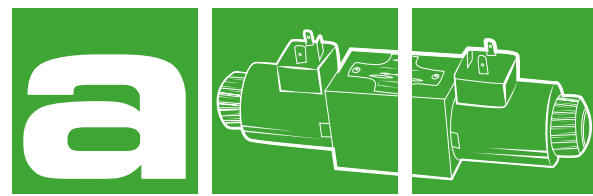

## 2-WAY PRESSURE COMPENSATOR MODULAR VALVES

### AM3-PC-\*

32 l/min - 32 MPa (320 bar)

#### 1 DESCRIPTION

2 Way pressure compensator for meter- in application. The pressure variations due to loading changes are compensated that means that an increase in pump pressure cannot result in any flow increase. Provided that there is no preloading of the outlet port, the use of a meter in pressure compensator is limited only to drives with exclusively positive load direction.

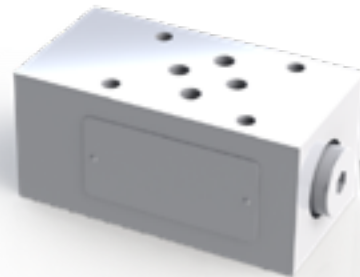

#### 2 ORDERING CODE

(1)	(2)	(3)	(4)	(5)	(6)		
AM3	-	PC	-	/	-	/	10

(1) AM3: stackable valve CETOP 03 - Pressure 32 MPa (320 bar)

(2) PC: pressure compensator 2-way valve

(3) Service lines where the controls operate:

P: control on P with A, B selection

A: control on A

B: control on B

(4) Pressure compensator  $\Delta p$

$\Delta p$  standard= 1MPa (10 bar)

(5) Code reserved for more options and variants

(6) Design number (progressive) of the valves

AM3-PC-P

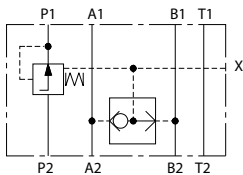

AM3-PC-A

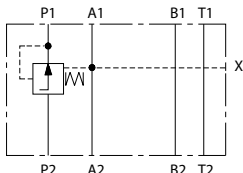

AM3-PC-B

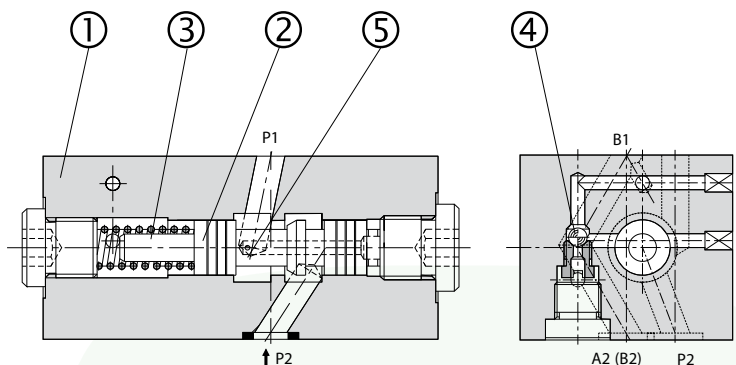
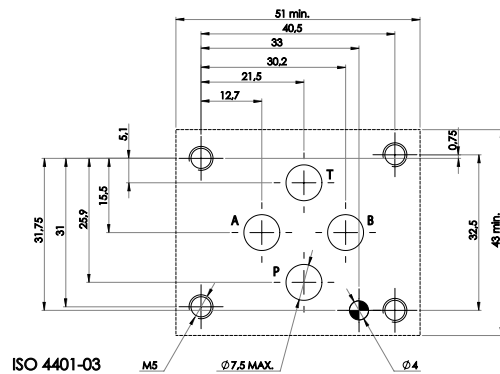
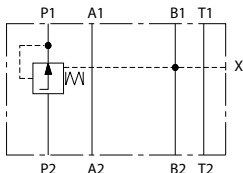

Valves AM3-PC-\* are directly operated 2-way pressure compensators .

The main parts of these valves are the housing 1, control spool 2, spring 3 and logic valve 4. The spring 3 holds the spool in the open position from P2 to P1, provided that the pressure difference between P1 and A ( $P1 - B$ ) is less than  $p = 10$  bar. When the pressure difference exceeds the value of  $p = 10$  bar, the spool shifts against spring until the desired pressure difference has been restored.

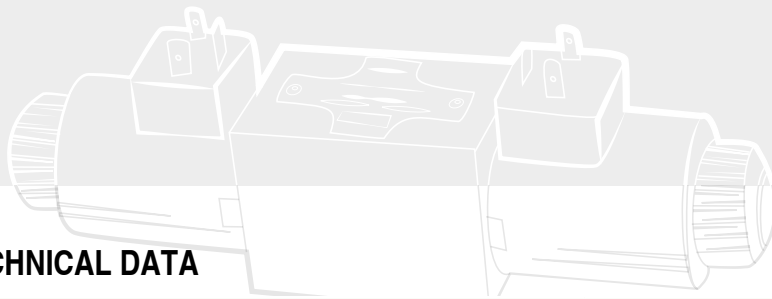

### 3 TECHNICAL DATA

Maximum rec. flow rate	32 l/min
Maximum nominal pressure	32 MPa (320 bar)
Pressure curves	see 4
Installation and dimensions	see 5
AM3-PC-P	approx 1,1 kg

### 4 TYPICAL DIAGRAMS

Typical curves for valves AM3-PC in standard configuration, with mineral oil at 36 cSt and at 50°C

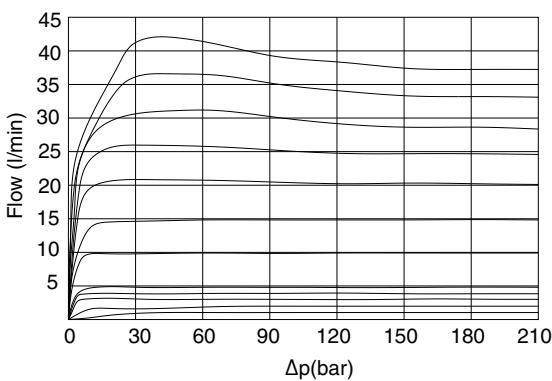

### EXAMPLE

Two way pressure compensator for meter-in application

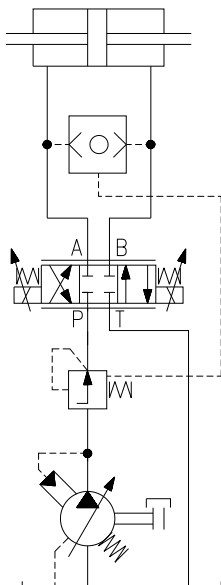

### 5 INSTALLATION DIMENSIONS (mm)

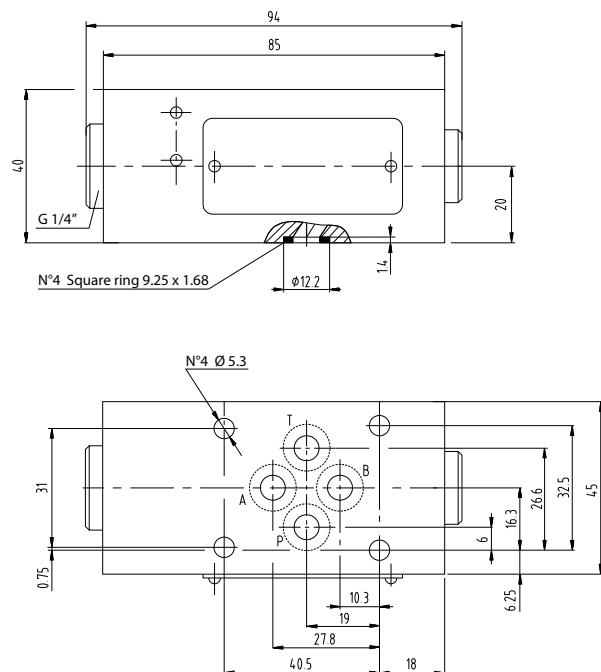

All stackable valves AM3-PC-\* conform with ISO and CETOP specifications for mounting surface dimensions and for valves height 40 mm. Leakage between valve and mounting surface is prevented by the positive compression on their seats of 4 seals type OR 2037.

### 6 HYDRAULIC FLUIDS

Seals and materials used on standard valve AM3-\* are fully compatible with hydraulic fluids of mineral oil base, upgraded with antifoaming and antioxidant agents. The hydraulic fluid must be kept clean and filtered to ISO 4406 class 19/17/14, or better, and used in a recommended viscosity range from 10 cSt to 60 cSt.

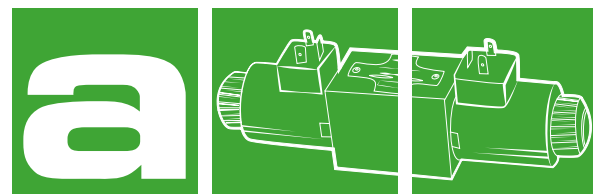

## PRESSURE COMPENSATED FLOW CONTROL VALVES

### AM3-Q3-P

40 l/min - 32 MPa (320 bar)

#### 1 DESCRIPTION

3 way pressure compensated flow control valves are designed to provide adjustable controlled flow rates independent of changes in system pressure.



#### 2 ORDERING CODE

(1)	(2)	(3)	(4)	(5)	(6)
AM3	-	Q3	-	P	/ 16 - / 10

(1) AM3: stackable valve CETOP 03 - Pressure 32 MPa (320 bar)

(2) Q3: 3-way pressure compensated flow control valves

(3) P: Service lines where the controls operate

(4) Flow control characteristics:

16=0,06-> 16l/min max regulated flow control rate to P1.

When the inlet flow (at P2) is more than the regulated value, the excess is discharged at T line

(5) Code reserved for more options and variants

(6) Design number (progressive) of the valves

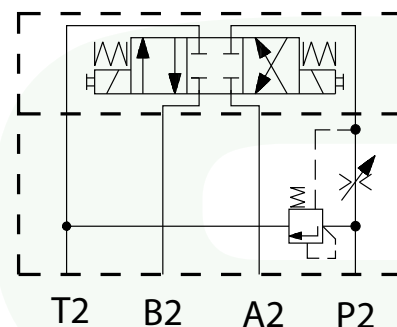
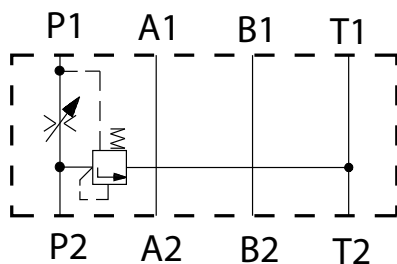
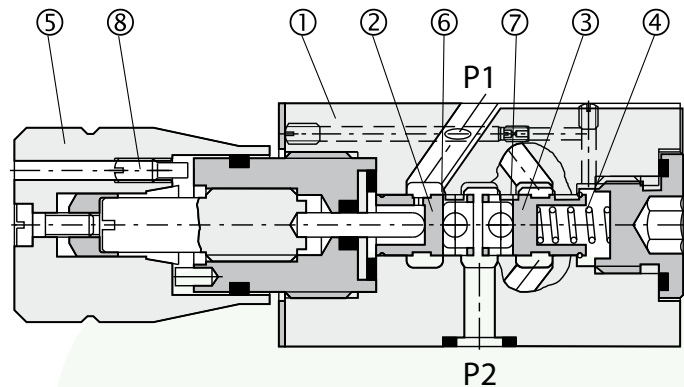
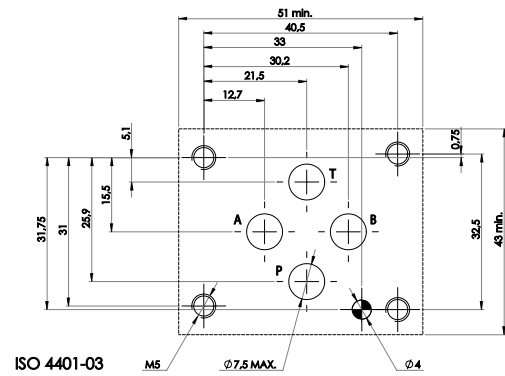

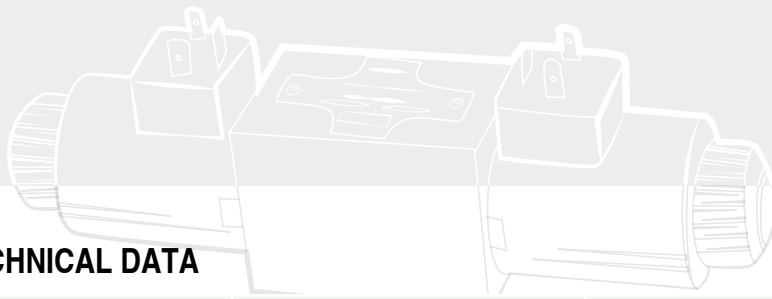

### 3 TECHNICAL DATA

Maximum rec. flow rate	40 l/min	Control of the flow: By turning the knob 5, the value of the regulated flow changes. The scale/flow characteristic is approx linear and the full range is covered by turning the knob by approx 320°. The scale is divided in 10 marks. Clockwise: flow increases Anticlockwise: flow decreases When the required value is reached, set the knob position by fixing screw 8.
Maximum flow rate on P1 port	16 l/min	
Maximum nominal pressure	32 MPa (320 bar)	
Flow curves	see 4	
Installation and dimensions	see 6	
Mass	approx 0,8 kg	

### 4 TYPICAL DIAGRAMS

Typical adjustment curves (Q-marcks and Q-P) for valves AM3-Q3-P in standard configuration

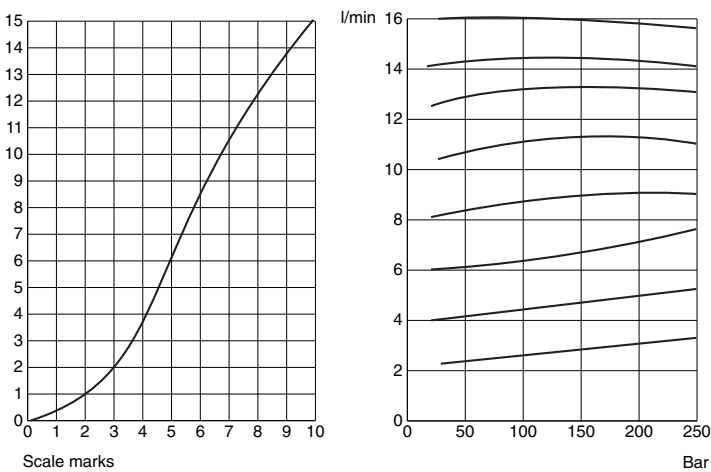

### 5 HYDRAULIC FLUIDS

Seals and materials used on standard valve AM3-\* are fully compatible with hydraulic fluids of mineral oil base, upgraded with antifoaming and antioxidantizing agents. The hydraulic fluid must be kept clean and filtered to ISO 4406 class 19/17/14, or better, and used in a recommended viscosity range from 10 cSt to 60 cSt.

### 6 INSTALLATION DIMENSIONS (mm)

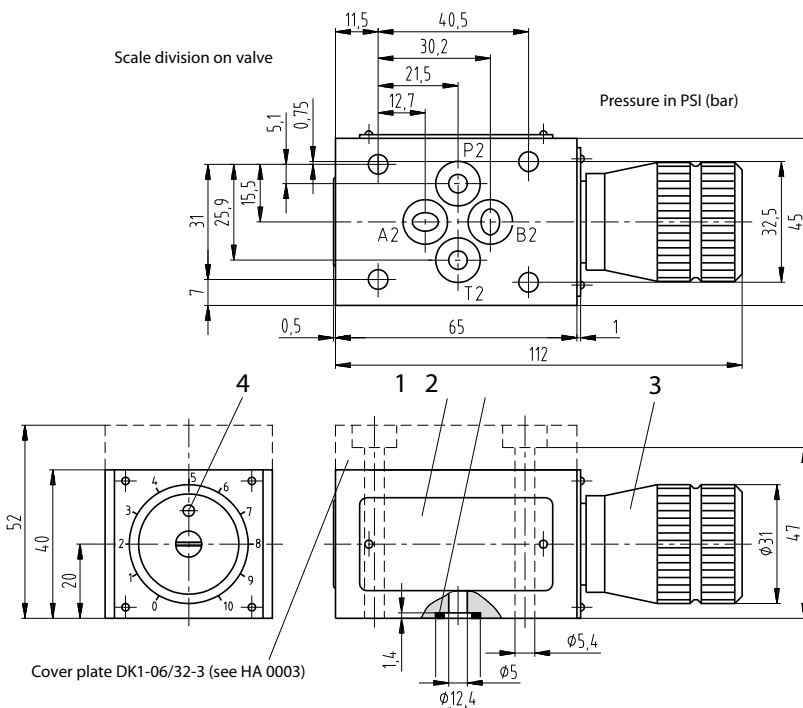

All stackable valves AM3-Q3-\* conform with ISO and CETOP specifications for mounting surface dimensions and for valves height 40 mm. Leakage between valve and mounting surface is prevented by the positive compression on their seats of 4 seals type OR 2037.

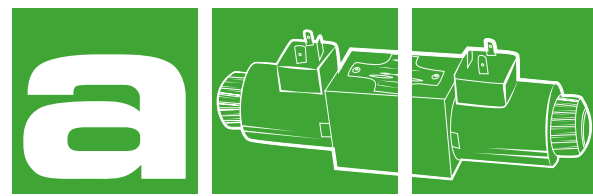

## PRESSURE COMPENSATED FLOW CONTROL VALVES

### AM3-Q\*-A

40 l/min - 32 MPa (320 bar)

#### 1 DESCRIPTION

Pressure compensated flow control valve designed to provide adjustable controlled flow independent of changes of pressure.



#### 2 ORDERING CODE

(1)	(2)	(3)	(4)	(5)	(6)			
AM3	-	Q*	-	A	/	-	/	10

(1) AM3: stackable valve CETOP 03 - Pressure 32 MPa (320 bar)

(2) Q: the options are:

QC: one-way pressure compensated flow control valves with meter-out control (referred to the hydraulic actuator)

QX: as above, with meter-in control

(3) A: Service lines where the controls operate

(4) Range of regulated flow:

06= 0-> 6 l/min

12= 0-> 12 l/min

22= 0-> 22 l/min

(5) Code reserved for more options and variants

(6) Design number (progressive) of the valves

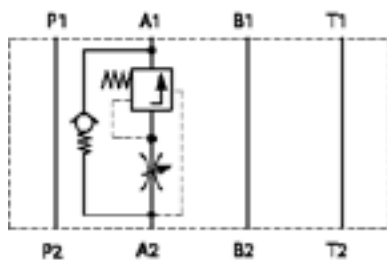
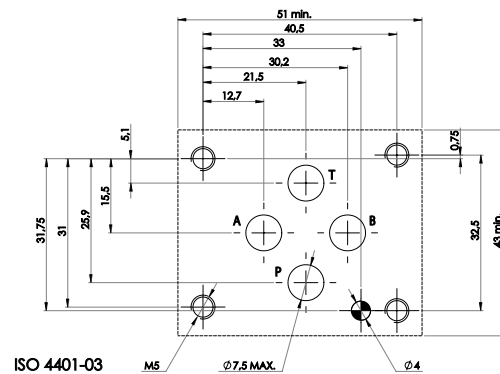

**AM3-QC-A**

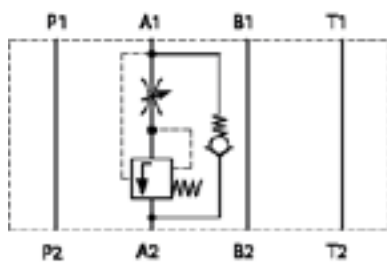

**AM3-QX-A**

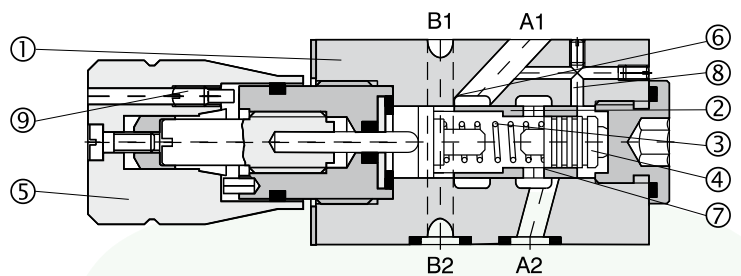



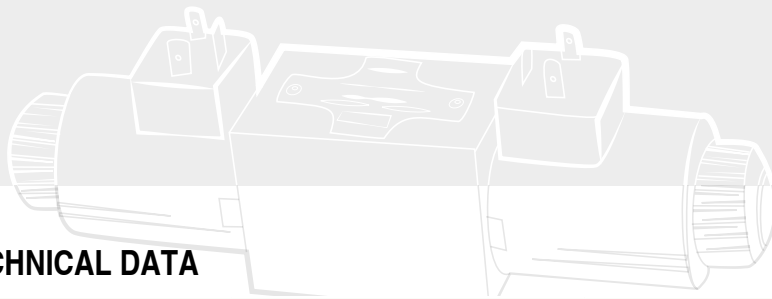

### 3 TECHNICAL DATA

Maximum rec. flow rate	40 l/min	Control of the flow: By turning the knob 5, the value of the regulated flow changes. The scale/flow characteristic is approx linear (see 4) and the full range is covered by turning the knob by approx 320°. The scale is divided in 10 marks. Clockwise: flow increases Anticlockwise: flow decreases When the required value is reached, set the knob position by fixing screw 8.
Maximum flow rate on A port	24 l/min	
Maximum nominal pressure	32 MPa (320 bar)	
Flow curves	see 4	
Installation and dimensions	see 5	
Mass	approx 0,8 kg	<p><math>\Delta p</math>-Q characteristics Pressure drops for reverse flow</p>

### 4 TYPICAL DIAGRAMS

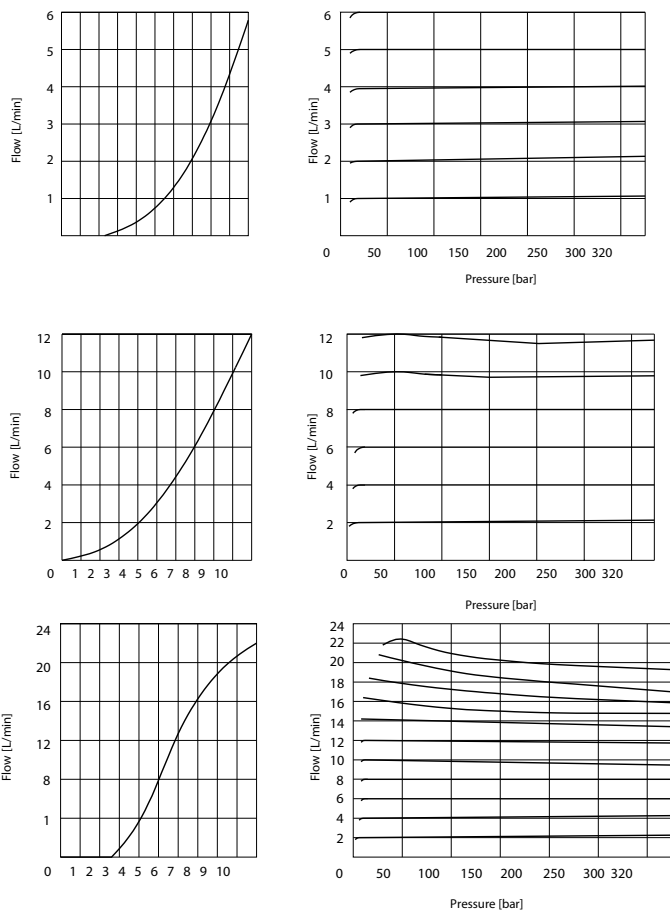

### 5 INSTALLATION DIMENSIONS (mm)

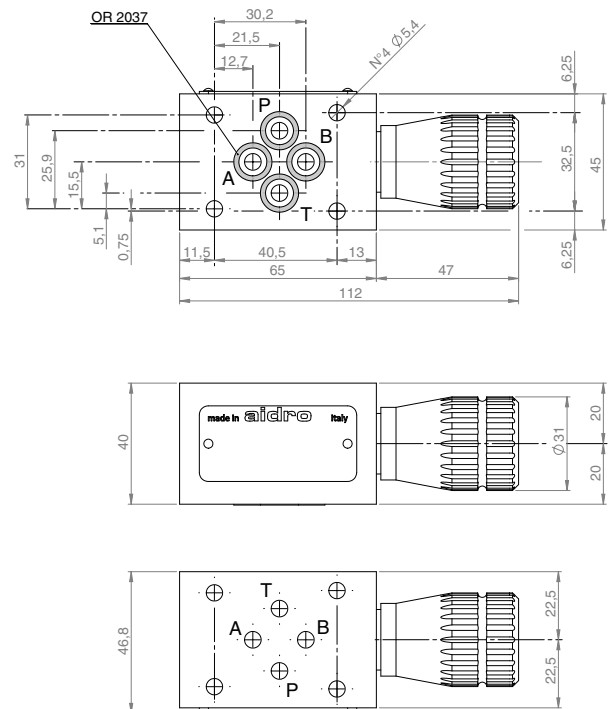

All stackable valves AM-Q\* conform with ISO and CETOP specifications for mounting surface dimensions and for valves height 40 mm. Leakage between valve and mounting surface is prevented by the positive compression on their seats of 4 seals type OR 2037.

### 6 HYDRAULIC FLUIDS

Seals and materials used on standard valve AM3\* are fully compatible with hydraulic fluids of mineral oil base, upgraded with antifoaming and antioxidizing agents. The hydraulic fluid must be kept clean and filtered to ISO 4406 class 19/17/14, or better, and used in a recommended viscosity range from 10 cSt to 60 cSt.

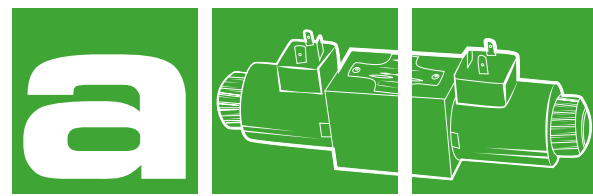

## PRESSURE COMPENSATED FLOW CONTROL VALVES

### QVC-06

32 l/min - 32 MPa (320 bar)

#### 1 DESCRIPTION

Pressure compensated flow control valve designed to provide adjustable controlled flow independent of changes of pressure.

#### 2 ORDERING CODE

(1)	(2)	(3)	(4)	(5)	(6)
QVC	- 06 /	-	-	-	/ 10

(1) QVC: pressure compensated, variable flow control valve with integral check valve for reverse flow

(2) 06: size CETOP 03- pressure 32 MPa (320 bar)

(3) Range of regulated flow:

01= 0 -> 1,6 l/min

03= 0 -> 3,2 l/min

06= 0 -> 6,3 l/min

16= 0 -> 16 l/min

32= 0 -> 32 l/min

(4) Pilot pressure arrangement

no designation: internal (standard)

E: external via P port

(5) Code reserved for more options and variants

no designation: no variant (standard)

K: key lock on the adjustment knob

(6) Design number (progressive) of the valves

without external pilot

with external pilot

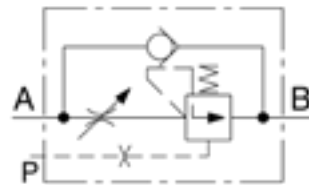
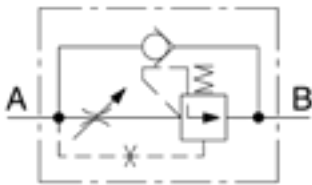

QVC-06/\*-E with external pilot is used for metering-in circuits to avoid "jumps" when the actuator starts

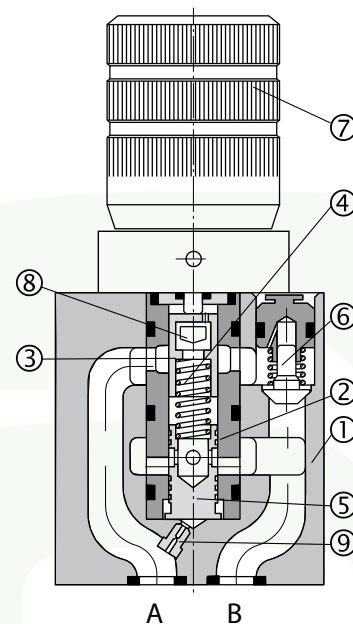
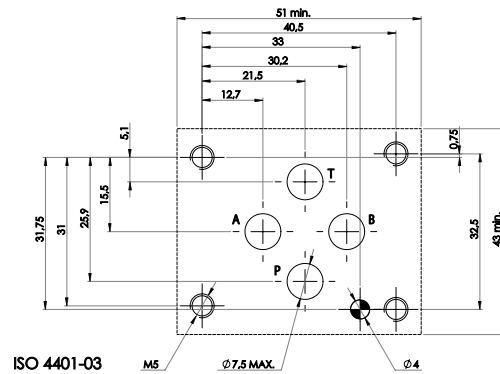
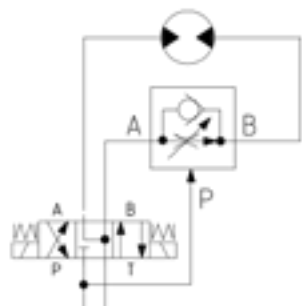



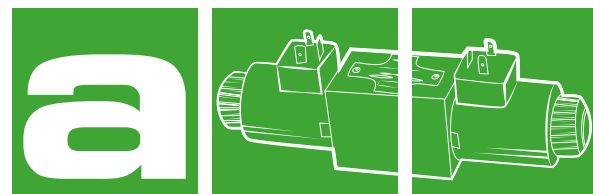

## SANDWICH VALVES WITH 3/4" 16 UNF 2-WAY CARTRIDGE VALVES

### 1 PRODUCTS OVERVIEW

In order to obtain an extensive flexibility in the design of the hydraulic circuits in systems based on CETOP 03 solenoid operated directional valves, Aidro introduces a new family of CETOP-03 modular bodies designed to be equipped with 3/4" 16 UNF 2-way cartridge valves. Since the cavity presents on the bodies is a standard (see 2) the circuit designer has the possibility to choice between a wide range of products (and therefore of functions) the cartridge valve to fit into the body. It's important to notice that the same cartridge valve perform different functions if fit in different bodies, thus further increasing the available configurations. Some of the possible functions are the following :

- Variable throttling
- Pressure compensated flow control (Meter-In or Meter-Out)
- Electric by-pass (normally open and normally closed)
- Unidirectional check valve

### 2 THE 3/4 16" UNF CAVITY

All the bodies of the family present SAE standard 2-way cavity 3/4" 16 UNF

For cartridge valves that perform flow control only in one direction (like check valves) 1 represents the inlet line, while 2 is the outlet.

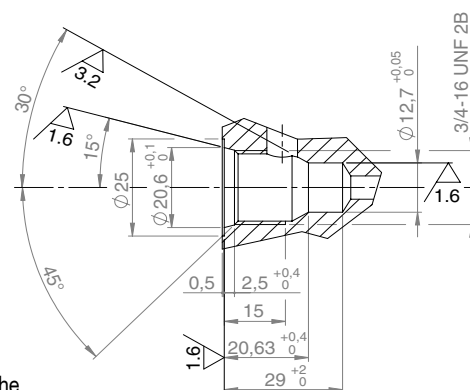

### 3 STANDARD BODIES

Three types of standard bodies are available :

**AM3\*-P/34**  
control on **P** line

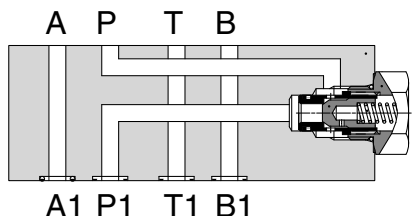

**AM3\*-ABX/34**  
control on **A** and/or **B** line  
(Meter-Out)

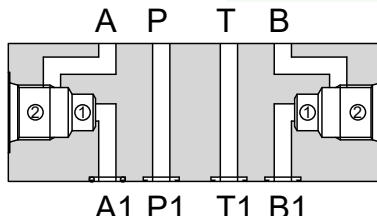

**AM3\*-ABC/34**  
control on **A** and/or **B** line  
(Meter-In)

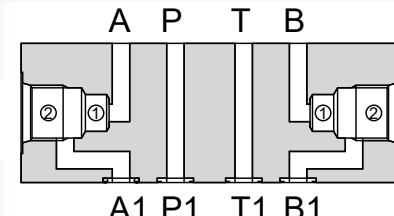

For a more detailed list of the functions available see the technical tables AM3\*-P/34, AM3\*-ABX/34 and AM3\*-ABC/34. Our technical department is available to study the feasibility of requested special configurations.



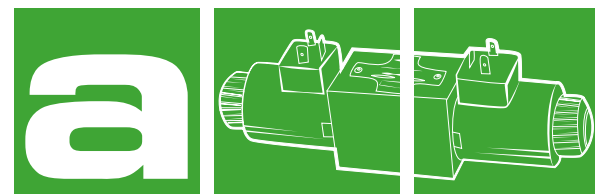

## CETOP 03 SANDWICH BODY FOR CARTRIDGE VALVES SAE STANDARD 2-WAY CAVITY 3/4 16" UNF ON A AND B LINES AM3-\***-C**

### 1 FUNCTIONAL SCHEME AND CONFIGURATION OPTIONS

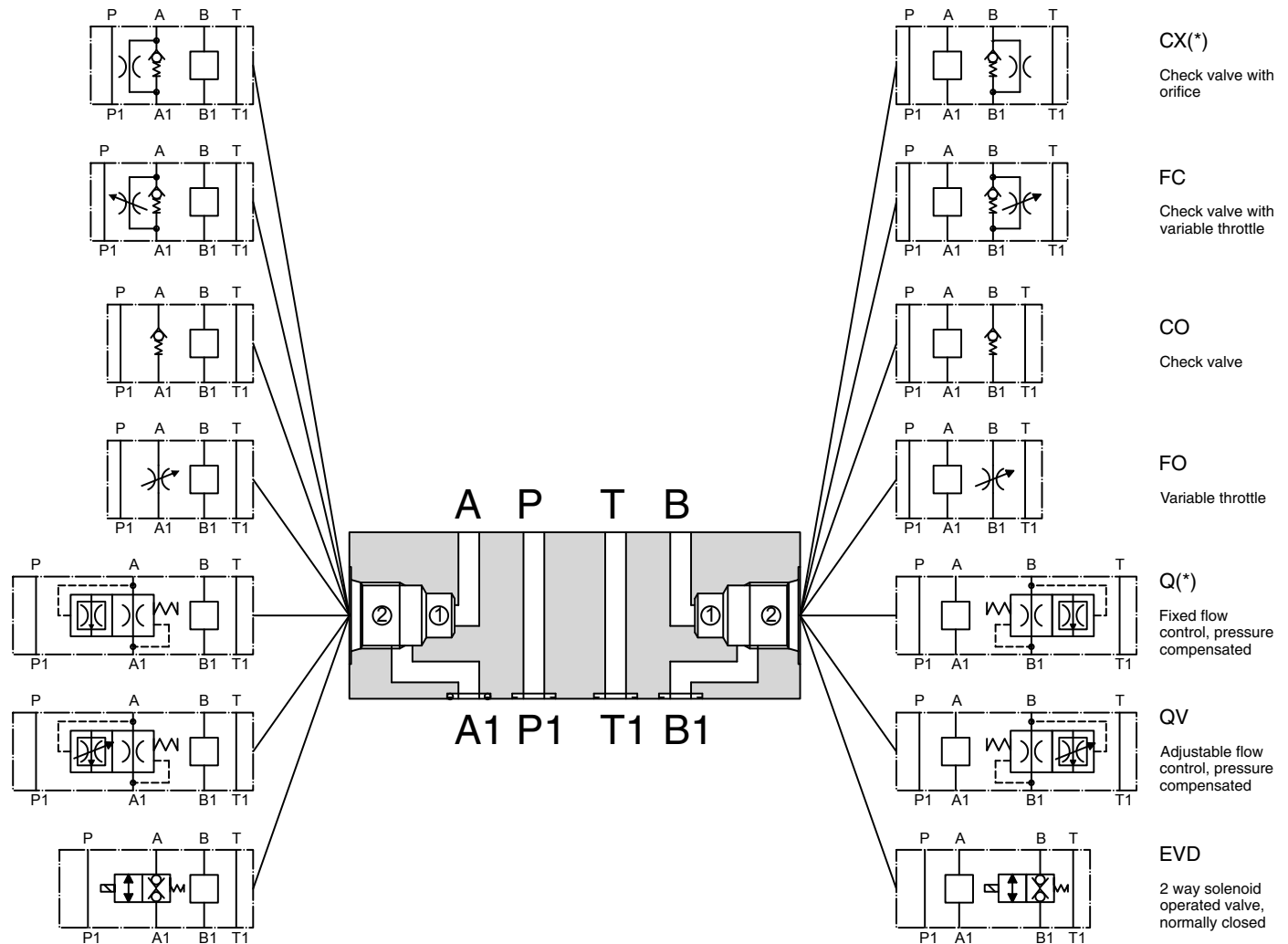

### 2 ORDERING CODE

(1)	(2)	(3)	(4)	(5)	(6)
AM3	-	-	C	/ 34	-

- (1) AM3: Size CETOP 03
- (2) Cartridge function (see the above schemes)
- (3) Lines where the valves operate ( A, B, AB)
- (4) C: orifices A and B connected to chambers 1:  
chambers 2 connected to ports A1 and B1
- (5) 34: 3/4" 16 UNF cavity (chambers 1 and 2)
- (6) Voltage for the solenoid operated valve  
024C: 24V DC  
012C: 12V DC  
230/50: 230V AC

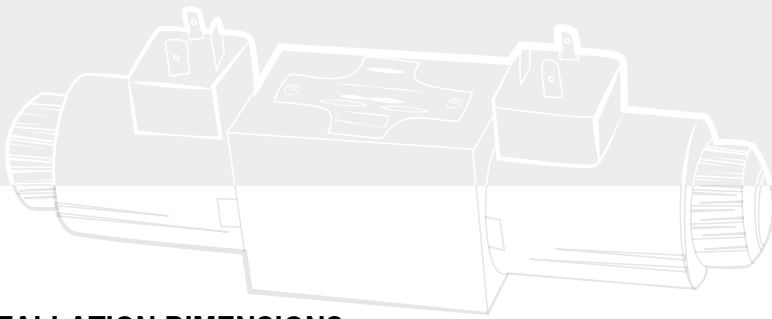

**3 INSTALLATION DIMENSIONS**

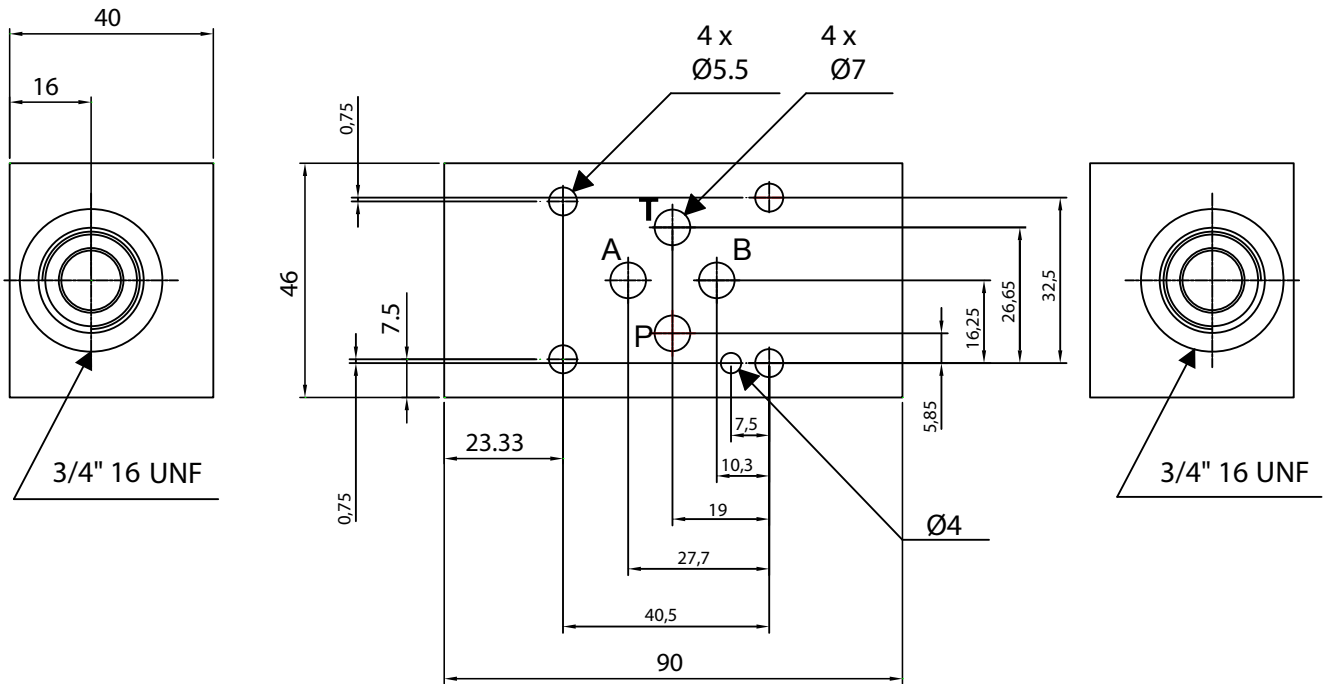

**4 3/4 16" UNF cavity (2-way)**

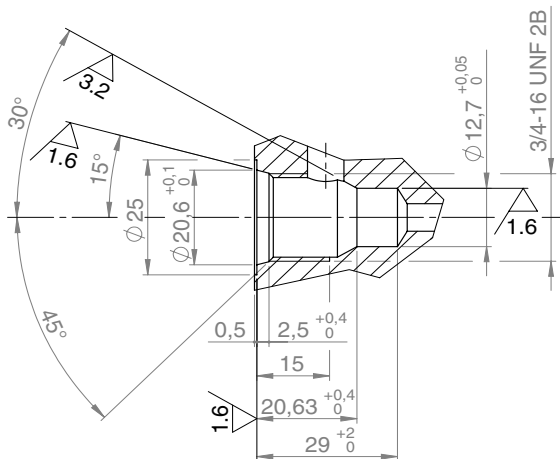

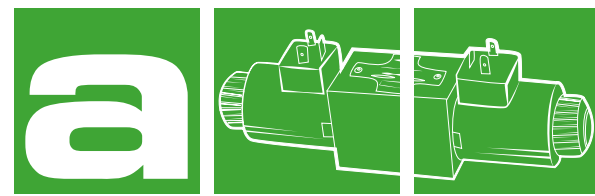

## CETOP 03 SANDWICH BODY FOR CARTRIDGE VALVES SAE STANDARD 2-WAY CAVITY 3/4 16" UNF ON A AND B LINES AM3-\*-X

### 1 FUNCTIONAL SCHEME AND CONFIGURATION OPTIONS

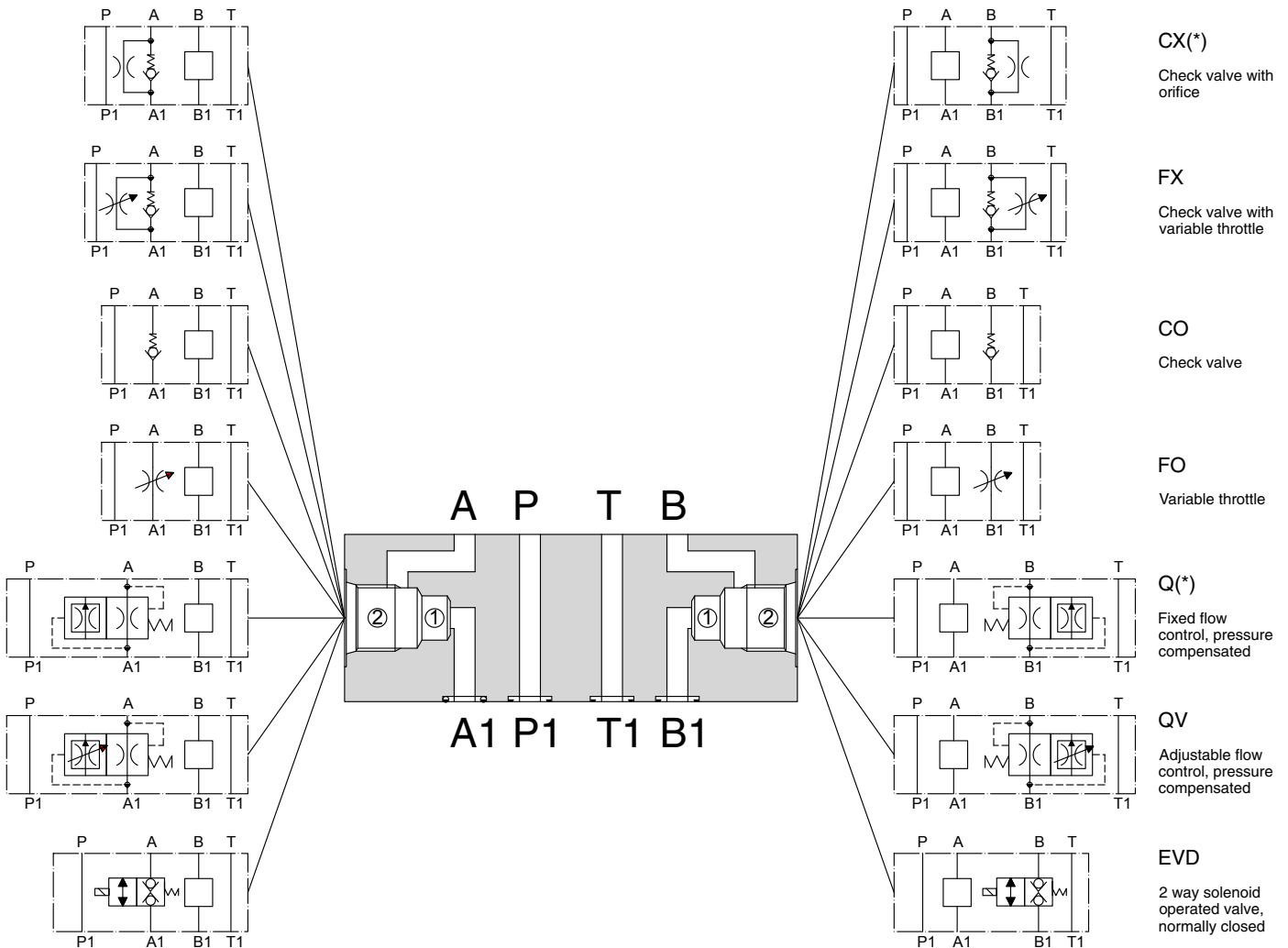

### 2 ORDERING CODE

(1)	(2)	(3)	(4)	(5)	(6)
AM3	-	-	X	/ 34	-

- (1) AM3: Size CETOP 03
- (2) Cartridge function (see the above schemes)
- (3) Lines where the valves operate ( A, B, AB)
- (4) X: orifices A and B connected to chambers 1: chambers 2 connected to ports A1 and B1
- (5) 34: 3/4" 16 UNF cavity (chambers 1 and 2)
- (6) Voltage for the solenoid operated valve:  
024C: 24V DC  
012C: 12V DC  
230/50: 230V AC



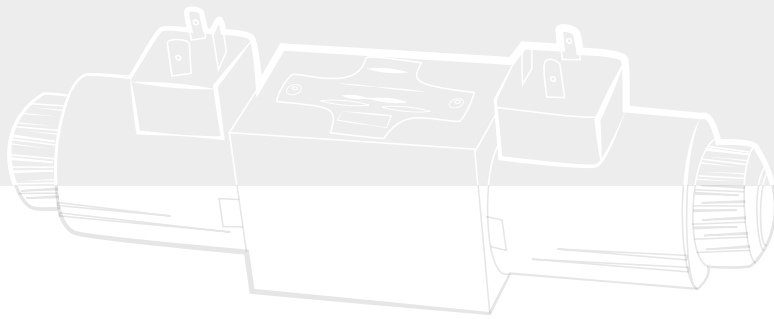

**3** INSTALLATION DIMENSIONS

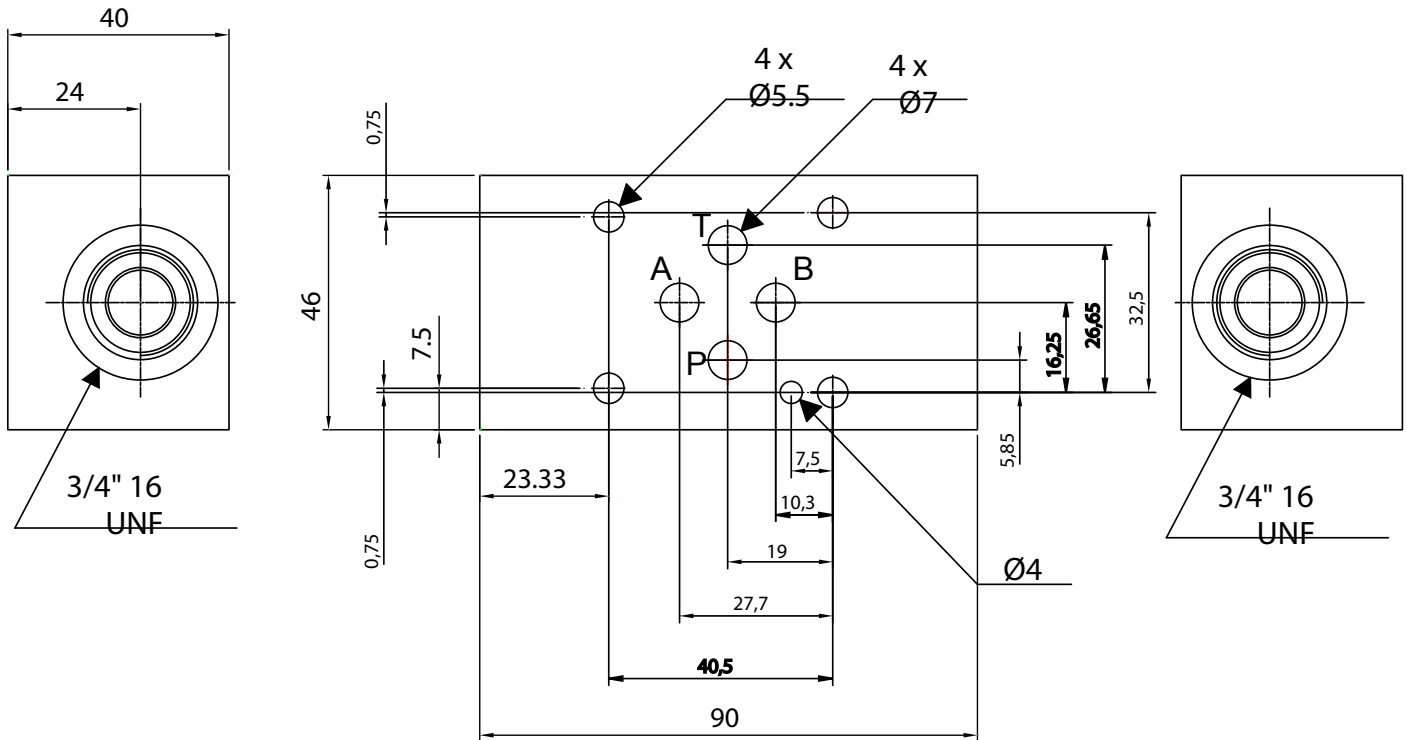

**4** 3/4 16" UNF cavity (2-way)

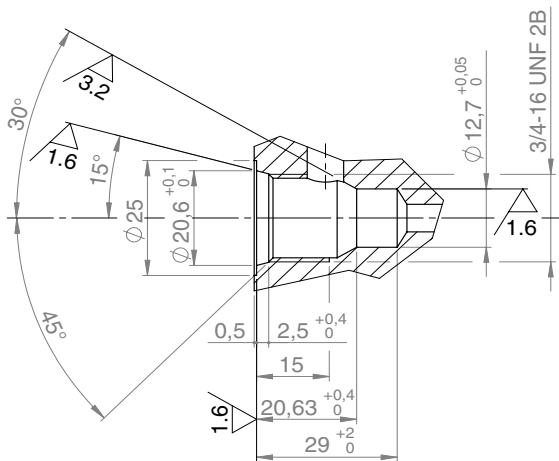

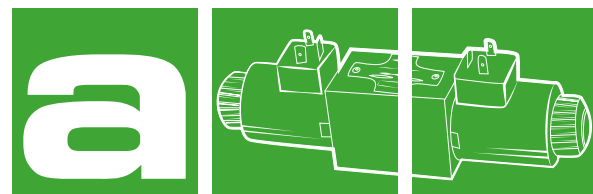

## STACKABLE VALVE CHECK VALVE ON P LINE

### AM3-CO-P/34

25 l/min - 32 MPa (320 bar)

#### 1 DESCRIPTION

Direct operated check valve. All the internal part are made with high strenght steel and are machined with accuracy in order to assure the requested tightness. The controlled lines is on P line. The standard surafce treatment of the body is phosphate coated. Plugs are zinc coated.



#### 2 ORDERING CODE

(1)	(2)	(3)	(4)	(5)	(6)	
AM3	-	CO	-	P	-	/ 34

(1) AM3: Stackable valve CETOP 03

(2) CO: Unidirectional check valve

(3) P: Line where the control operates

(4) Check valve opening (cracking) pressure (Pm):  
no designation: Pm approx. 0.3 MPa (3 bar)  
8: Pm approx. 0.8 MPa (8 bar)

(5) Code reserved for more options and variants

(6) Cavity for cartridge valves is 3/4" 16 UNF

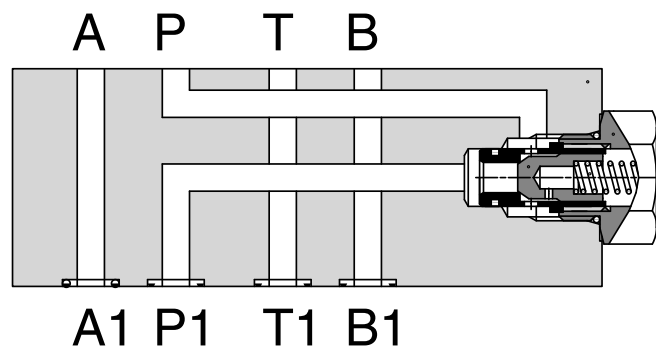
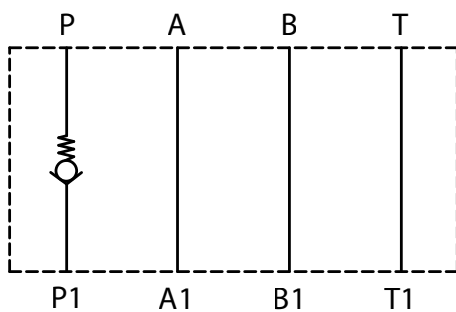
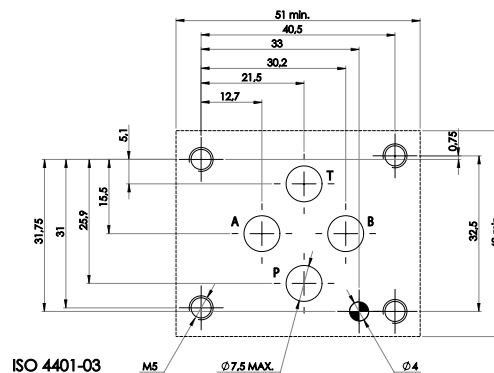

Fluid flows freely in A, B and T lines. When pressure in P1 overcomes the sum of the pressure in P and the pressure due to the pre-load of spring, the poppet shifts axially and fluid flows from P1 to P. Reverse flow is prevented (without leakage) by the poppet, which kept against its seat by spring.

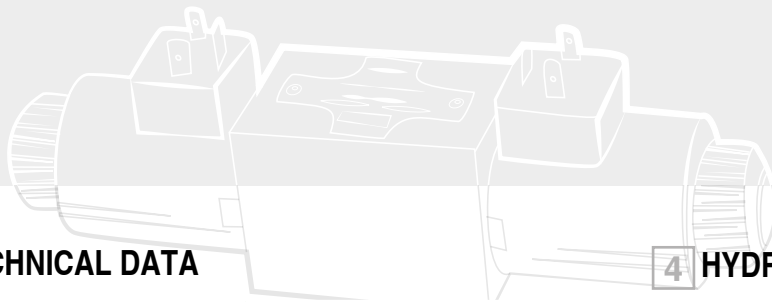

### 3 TECHNICAL DATA

Maximum rec. flow rate on P line	25 l/min
Maximum nominal pressure	32 MPa (320 bar)

### 4 HYDRAULIC FLUIDS

Seals and materials used on standard valves AM3-\* are fully compatible with hydraulic fluids of mineral oil base, upgraded with antifoaming and antioxidantizing agents. The hydraulic fluid must be kept clean and filtered to ISO 4406 class 19/17/14, or better, and used in a recommended viscosity range from 10cSt to 60 cSt.

### 5 TYPICAL DIAGRAMS

measured at  $v = 36$  cSt and  $50^\circ\text{C}$

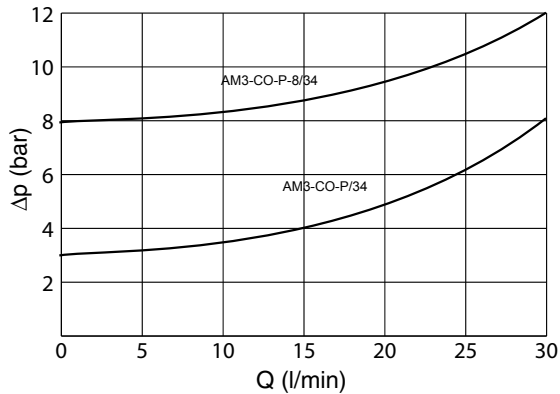

### 6 INSTALLATION DIMENSIONS (mm)

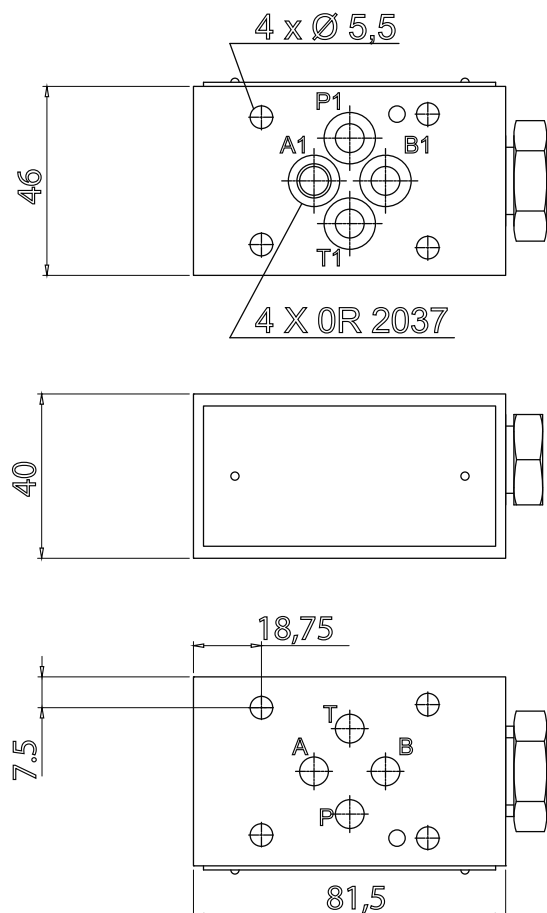

All stackable valves AM3-\* conform with ISO and CETOP specifications for mounting surface dimensions and for valves height (40 mm). Leakage between valve and mounting surface is prevented by the positive compression on their seats of 4 seals of OR type

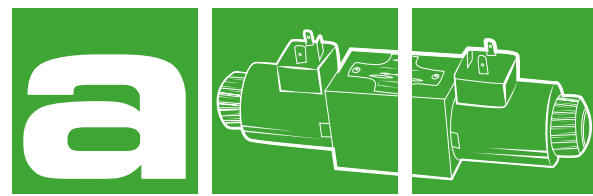

## STACKABLE VALVE ADJUSTABLE FLOW CONTROL

### AM3-FO-P/34

25 l/min - 32 MPa (320 bar)

#### 1 DESCRIPTION

Stackable valve CETOP 3 with flow restrictor function. With this model it is possible to control the line P.

On demand it is possible to have also the fine control option.



#### 2 ORDERING CODE

(1)	(2)	(3)	(4)	(5)	(6)
AM3	-	FO	-	P	-
					/
					34

(1) AM3: Stackable valve CETOP 03

(2) FO: adjustable flow control valve

(3) P: Line where the control operates

(4) Flow adjustment device :  
no designation : hexagon screw  
M: hand knob

(5) Code reserved for more options and variants

(6) Cavity for cartridge valves is 3/4" 16 UNF

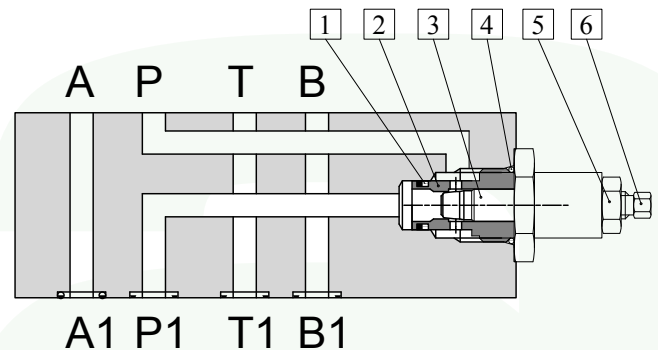
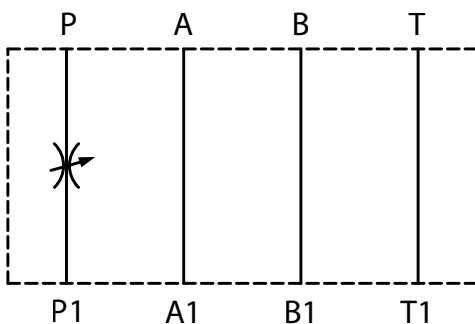
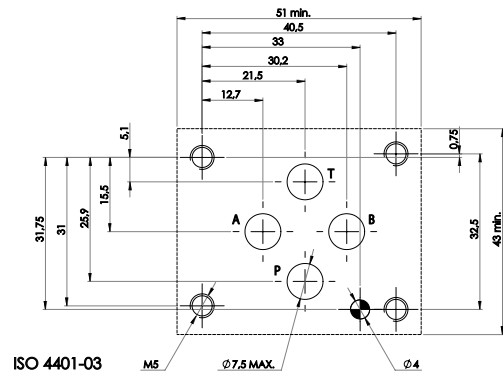

Fluid flows freely on A, B and T lines. Fluid that flows on P line is regulated by a variable throttle valve, consisting in a needle 3 (which position is set by the adjustment screw 6) that changes the section of an annular passage.

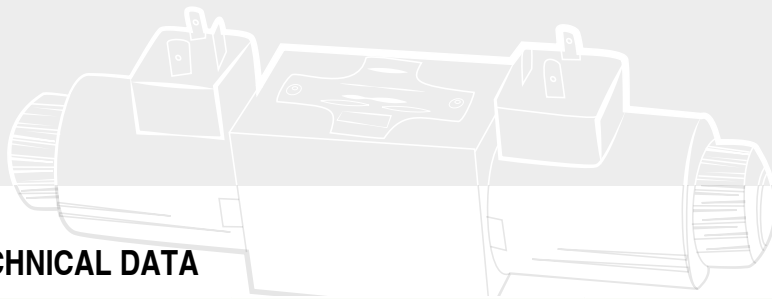

### 3 TECHNICAL DATA

Maximum rec. flow rate on P line	25 l/min	Adjustment of the regulated flow:
Maximum nominal pressure	32 MPa (320 bar)	To decrease flow in P line turn clockwise the adjustment screw 6 (or the hand knob), after having unlocked its retaining nut 5

### 4 TYPICAL DIAGRAMS

measured at  $\nu = 36$  cSt and  $50^\circ\text{C}$

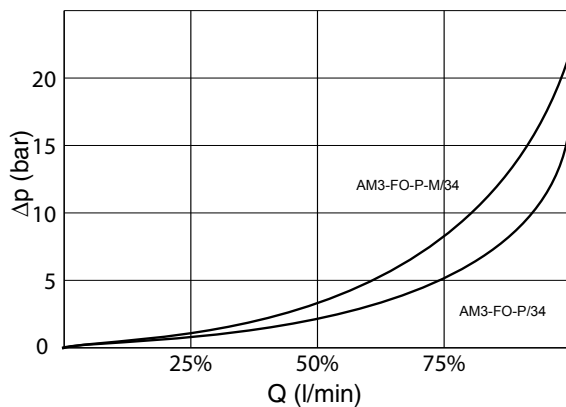

### 5 HYDRAULIC FLUIDS

Seals and materials used on standard valves AM3-\* are fully compatible with hydraulic fluids of mineral oil base, upgraded with antifoaming and antioxidantizing agents. The hydraulic fluid must be kept clean and filtered to ISO 4406 class 19/17/14, or better, and used in a recommended viscosity range from 10 cSt to 60 cSt.

### 6 INSTALLATION DIMENSIONS (mm)

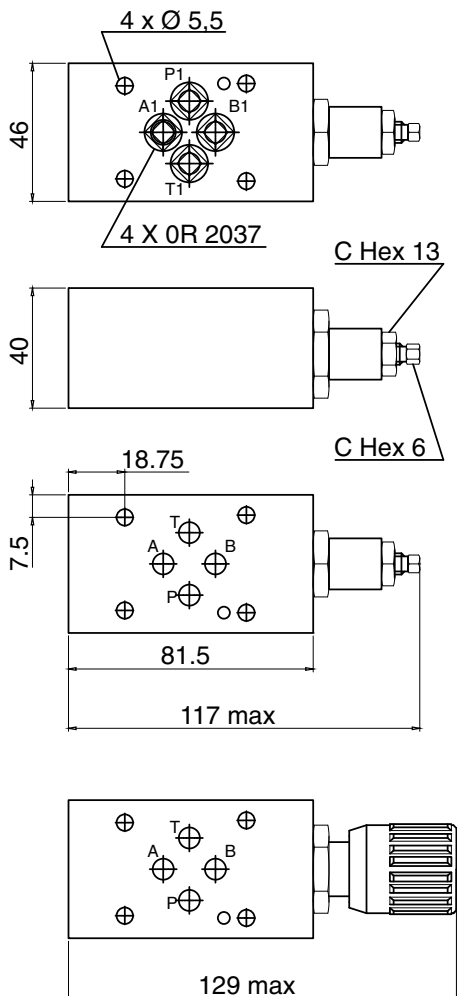

All stackable valves AM3-\* conform with ISO and CETOP specifications for mounting surface dimensions and for valves height (40 mm). Leakage between valve and mounting surface is prevented by the positive compression on their seats of 4 seals of OR type

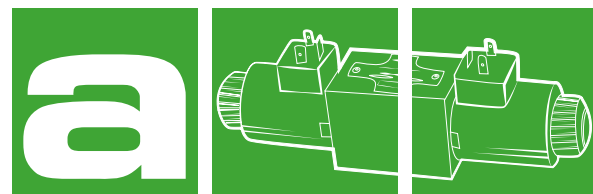

## STACKABLE VALVE PRESSURE COMPENSATED, FIXED CONTROL VALVES

### AM3-Q\*-P/34

32 MPa (320 bar)

#### 1 DESCRIPTION

Stackable valve CETOP 3 with flow restrictor function pressure compensated. With this model It is possible to control the line P. Different orifice sizes are available.



#### 2 ORDERING CODE

(1)	(2)	(3)	(4)	(5)	(6)
AM3	-	Q	-	P	/ 34

- (1) AM3: Stackable valve CETOP 03
- (2) Q: Pressure compensated, fixed flow control
- (3) Flow rate setting ( see 3 )
- (4) P: Line where the control operates
- (5) Code reserved for more options and variants
- (6) Cavity for cartridge valves is 3/4" 16 UNF

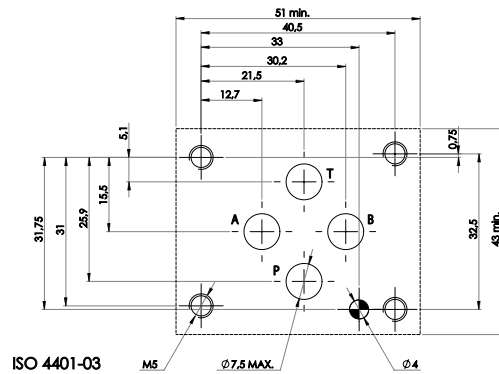

### AM3-Q(\*)-P/34

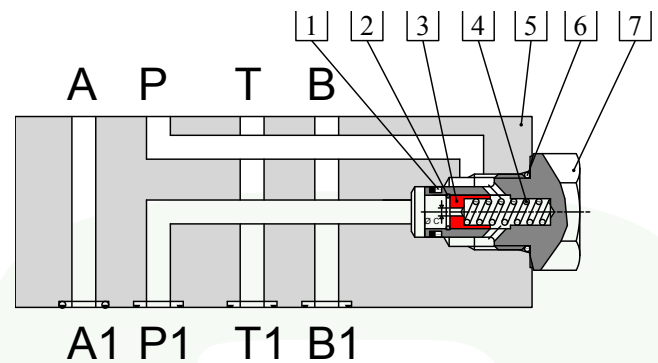
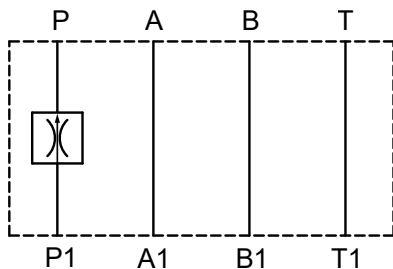

Fluid flows freely in A, B and T lines. P1->P : fluid flows through orifice of throttle 3 (flow rate depending on the value orifice diameter Ø C). When pressure difference between P1 and P increases, throttle 3 moves against spring 4 and reduces the area of the lateral orifices, thus keeping flow rate constant at the requested value.

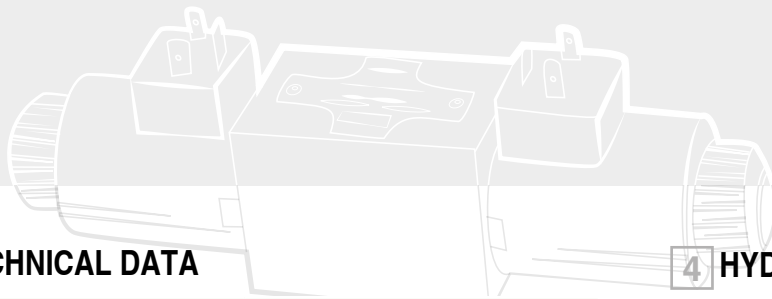

### 3 TECHNICAL DATA

Maximum rec. flow rate on P line	25 l/min
Maximum nominal pressure	32 MPa (320 bar)

Approximate flow rates corresponding with the orifice Ø C		
Ordering Code	ORIFICE Ø C (mm)	Flow (l/min)
AM3-Q1-P/34	0,8	1
AM3-Q2-P/34	1	2
AM3-Q3-P/34	1,25	3
AM3-Q4-P/34	1,5	4
AM3-Q5-P/34	1,75	5
AM3-Q6-P/34	2	6
AM3-Q9-P/34	3	9
AM3-Q12-P/34	4	12

### 4 HYDRAULIC FLUIDS

Seals and materials used on standard valves AM3-\* are fully compatible with hydraulic fluids of mineral oil base, upgraded with antifoaming and antioxidizing agents. The hydraulic fluid must be kept clean and filtered to ISO 4406 class 19/17/14, or better, and used in a recommended viscosity range from 10 cSt to 60 cSt.

### 5 INSTALLATION DIMENSIONS (mm)

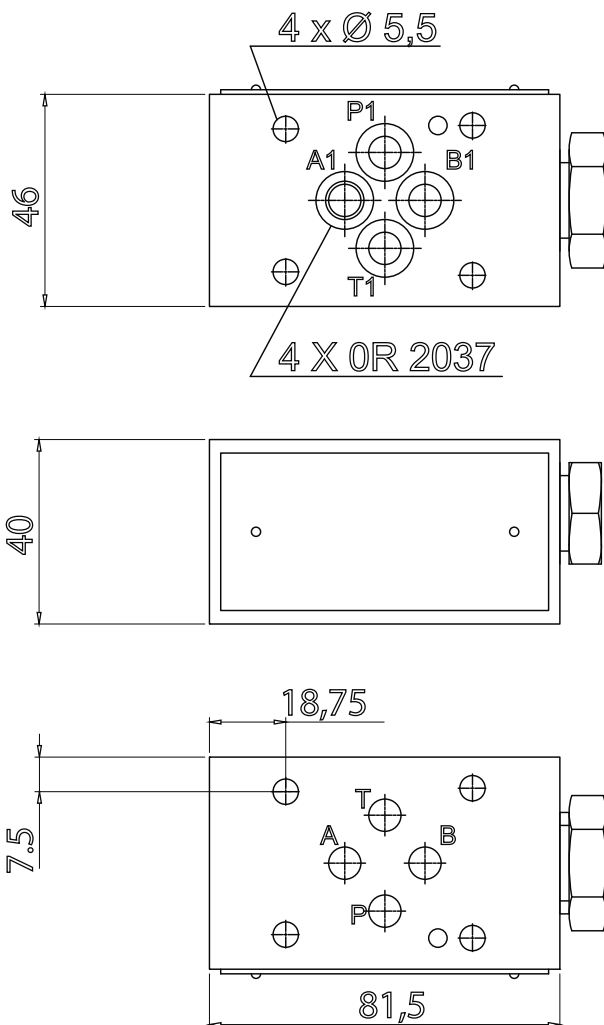

All stackable valves AM3-\* conform with ISO and CETOP specifications for mounting surface dimensions and for valves height (40 mm). Leakage between valve and mounting surface is prevented by the positive compression on their seats of 4 seals of OR type

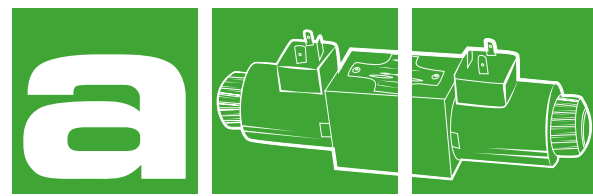

## STACKABLE VALVE LOCK, SOLENOID OPERATED CONTROL VALVE ON P LINE

### AM3-EVD-P/34-(024C)

25 l/min 25 MPa (250 bar)

#### 1 DESCRIPTION

Stackable valve CETOP 3 with double poppet solenoid valve on P line.  
 With this model It is possible to control the line P.  
 Different voltages are available.

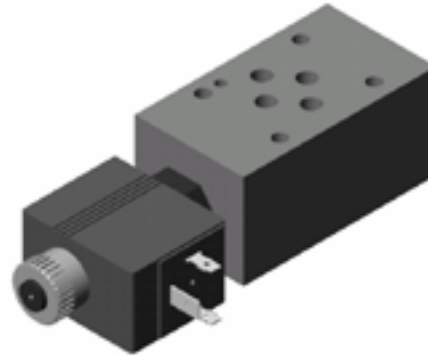

#### 2 ORDERING CODE

(1)	(2)	(3)	(4)	(5)	(6)
AM3	-	EVD	-	P	-
				/	34

(1) AM3: Stackable valve CETOP 03

(2) EVD: 2-way solenoid operated poppet valve

(3) P: Line where the control operates

(4) Code reserved for more options and variants

(5) 34: cavity for cartridge valves is 3/4" 16 UNF

(6) Electric voltage and solenoid coils:

0000: no coils

012C: coils for V12DC

024C: coils for V24DC

220R: coils for V220-230 RAC

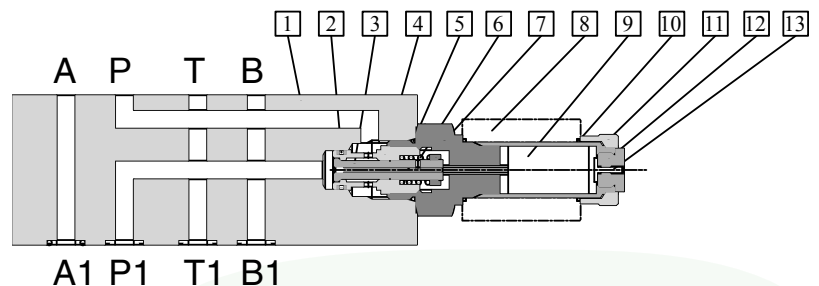
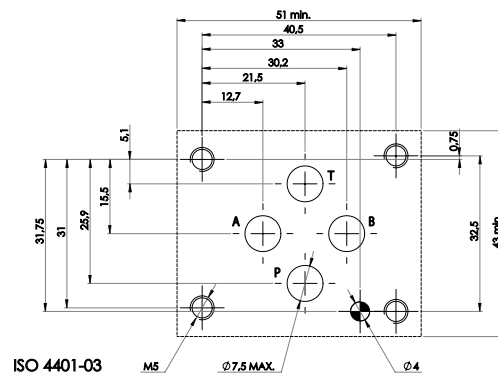

### AM3-EVD-P/34-024C

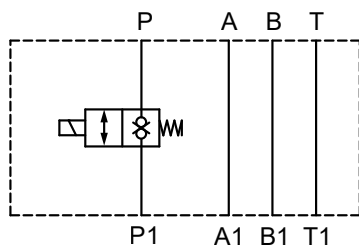

The poppet 3 is balanced by pressure and it is kept against its seat 4 by spring 6. When the solenoid 8 is energized, the mobile armature 9 moves the poppet 3 against spring 6, thus permitting flow between P1 and P. The manual override 13 is of the pin type and, when pushed, it permits the valve's operation in case of electric failure.



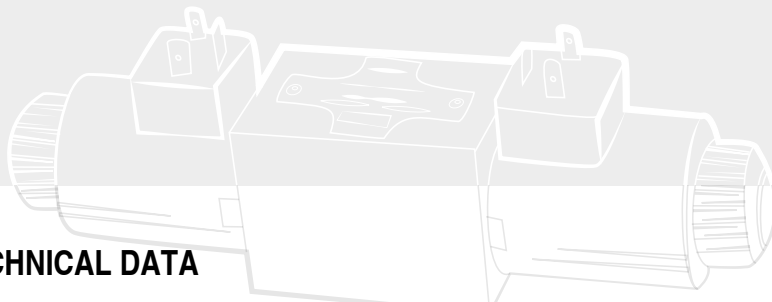

### 3 TECHNICAL DATA

Maximum nominal pressure	25 MPa (250 bar)	Electric features:
Nominal flow rate on P line	16 l/min	Those solenoid valves are normally equipped by coils type C33, which are energized from DC or AC supply. Coils type C33-***C are DC energized directly from a V***DC supply. Coils type C33-***R are RAC (Rectified Alternate Current) energized from a V***AC supply, by a full wave bridge rectifier incorporated in the connector. Coils type C33 are normally provided for use of ISO4400/DIN43650/A connectors. Standard coils are compatible with KA-132 connectors (see table)
Maximum rec. flow rate on P line	20 l/min	

### 4 TYPICAL DIAGRAMS

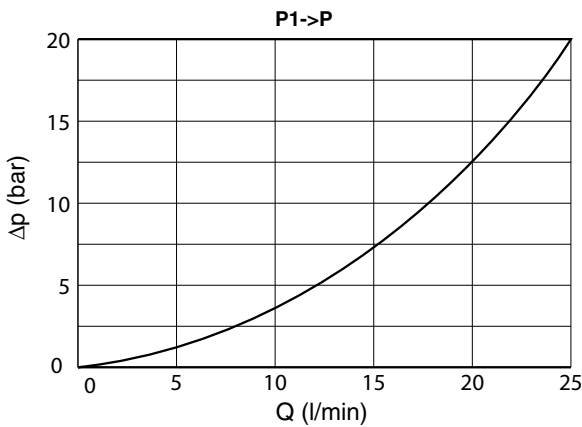

### 5 INSTALLATION DIMENSIONS (mm)

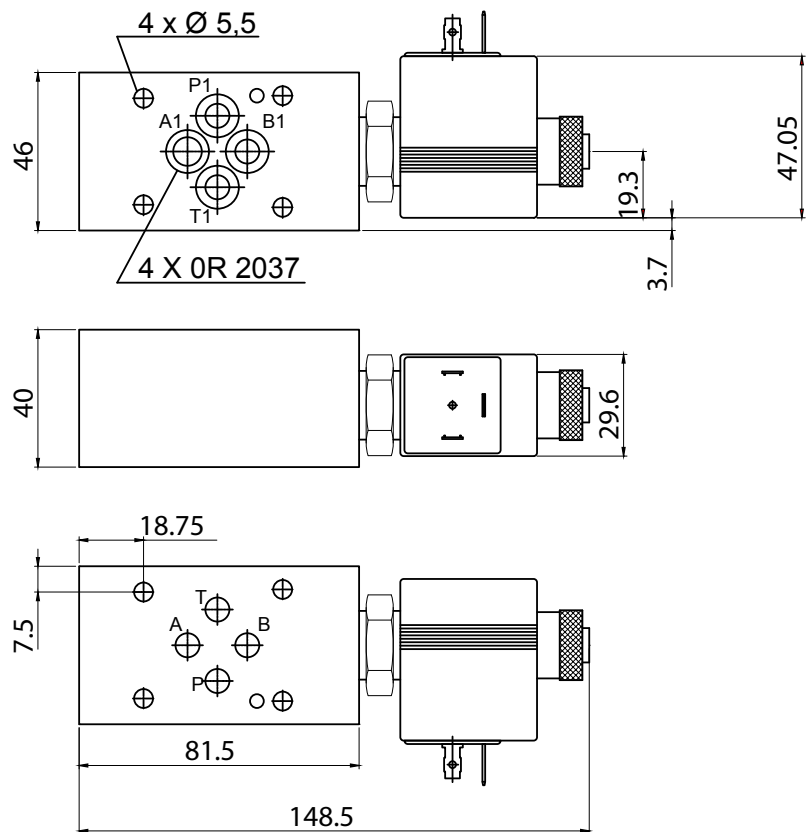

### 6 HYDRAULIC FLUIDS

Seals and materials used on standard valves AM3-\* are fully compatible with hydraulic fluids of mineral oil base, upgraded with antifoaming and antioxidantizing agents. The hydraulic fluid must be kept clean and filtered to ISO 4406 class 19/17/14, or better, and used in a recommended viscosity range from 10 cSt to 60 cS

All stackable valves AM3-\* conform with ISO and CETOP specifications for mounting surface dimensions and for valves height (40 mm). Leakage between valve and mounting surface is prevented by the positive compression on their seats of 4 seals of OR type

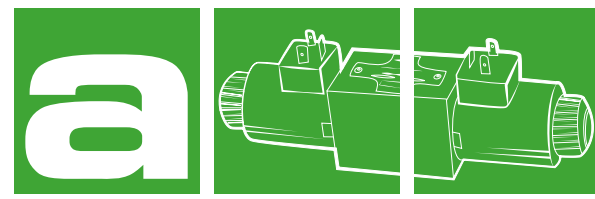

## MONOBLOCK WITH MULTIPLE SECTIONS ISO 03

### MR-3-\*G

80 l/min 30 MPa (300 bar)

#### 1 DESCRIPTION

Ports A and B (3/8" BSP) on the sides P and T lines with ports (1/2" BSP) on the two rear sides Parallel connections P and T Monoblocks with multiple sections from 1 to 8, for hydraulic 4 ways operated valves ISO 03 with parallel internal connections P and T. The utility ports A and B are positioned laterally to the valve assembly face.

#### 2 ORDERING CODE

(1)	(2)	(3)	(4)
MR	-	3	G

#### 3 TECHNICAL DATA

Material:	Cast Iron GG 25
Coating:	Manganese phosphating
Pressure allowed in the ports:	P, A, B and T = 300 bar
Incoming flow, maximum recommended: (*)	From 40 to 80 l/min, decreasing with the rise of the number of sections. If both pairs of ports P and T are used, maximum recommended Q values can be increased.
Connecting ports:	Standard cylindrical BSP thread with maximum rugosity of a surface Ra 1,6 for the fitting of connections.
A and B ports P:	3/8" BSP one pair per section
P and T:	1/2" BSP one pair on each rear side of a monoblock; it allows to double supply if needed (P) or double outlet (T); close the unused ports

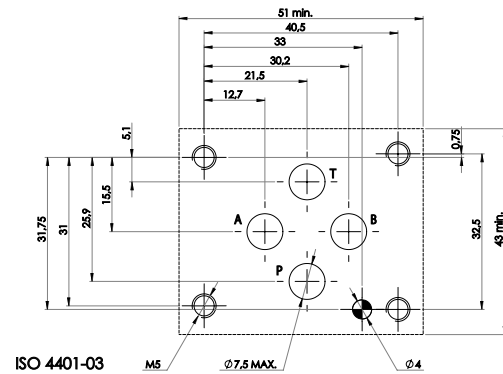

Type	Number of sections 03	Q max recommended (*) l/min
MR-3-1 G	1	80 - 80
MR-3-2 G	2	80 - 80
MR-3-3 G	3	60 - 80
MR-3-4 G	4	60 - 80
MR-3-5 G	5	50 - 80
MR-3-6 G	6	50 - 80
MR-3-7 G	7	40 - 80
MR-3-8 G	8	40 - 80

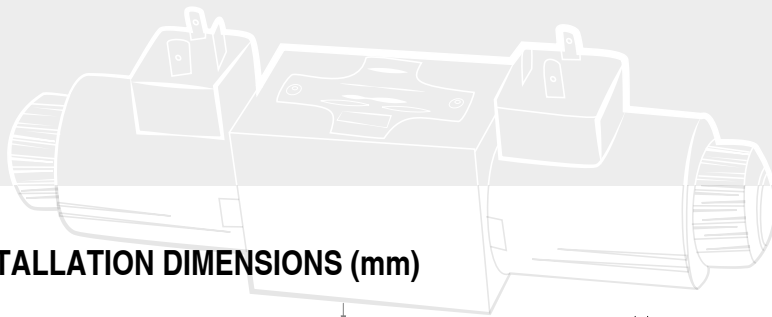

## 4 INSTALLATION DIMENSIONS (mm)

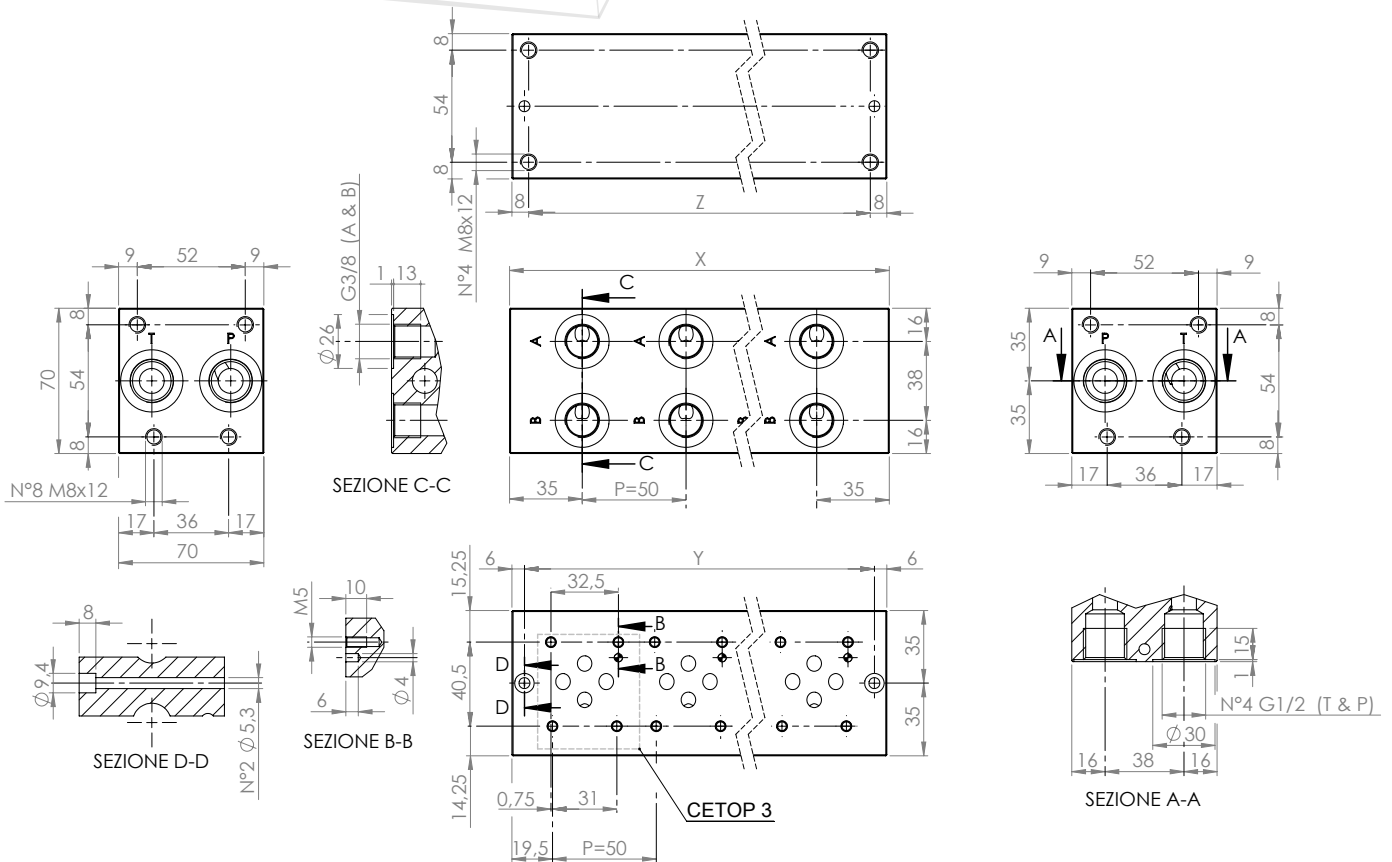

- 2 passing holes diameter  $\phi$  5,5 mm, with a counterbore for a bolt head with diameter  $\phi$  9x8 mm
- 4 mounting holes threaded M8 on the rear side

Type	X (mm)	Y (mm)	Z (mm)	mass (kg)
MR-3-1 G	70	58	54	2,10
MR-3-2 G	120	108	104	3,60
MR-3-3 G	170	158	154	5,20
MR-3-4 G	220	208	204	6,70
MR-3-5 G	270	258	254	8,30
MR-3-6 G	320	308	304	9,80
MR-3-7 G	370	358	354	11,40
MR-3-8 G	420	408	404	13,00

## 5 HYDRAULIC FLUID

Seals and materials used on standard valves MR-3\*G are fully compatible with hydraulic fluids of mineral oil base, upgraded with antifoaming and antioxidizing agents. The hydraulic fluid must be kept clean and filtered to ISO 4406 class 19/17/14, or better, and used in a recommended viscosity range from 10 cSt to 60 cS

## 6 MOUNTING SURFACE OF THE VALVE:

Planarity of the surface: 0,01/100  
 rugosity: Ra 0,8  
 Every section has a mounting surface according to ISO 4401-03.

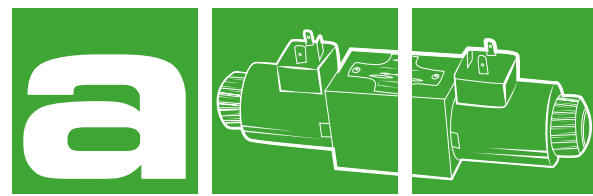

## MONOBLOCK WITH MULTIPLE SECTIONS ISO 03

### MRK-3-\*G

80 l/min 30 MPa (300 bar)

#### 1 DESCRIPTION

Ports A and B (3/8" BSP) on the back P and T lines with ports (1/2" BSP) on the two rear sides Parallel connections P and T Monoblocks with multiple sections from 2 to 8, for hydraulic 4 ways operated valves ISO 03 with parallel internal connections P and T. Ports A and B are positioned on the back side of the block relative to the valve assembly face.

#### 2 ORDERING CODE

(1)	(2)	(3)	(4)
MRK	-	3	-
			G

#### 3 TECHNICAL DATA

Material:	Cast Iron GG 25
Coating:	Manganese phosphating
Pressure allowed in the ports:	P, A, B and T = 300 bar
Incoming flow, maximum recommended: (*)	From 40 to 80 l/min, decreasing with the rise of the number of sections. If both pairs of ports P and T are used, maximum recommended Q values can be increased.
Connecting ports:	Standard cylindrical BSP thread with maximum rugosity of a surface Ra 1,6 for the fitting of connections.
A and B ports P:	3/8" BSP one pair per section
P and T:	1/2" BSP one pair on each rear side of a monoblock; it allows to double supply if needed (P) or double outlet (T); close the unused ports

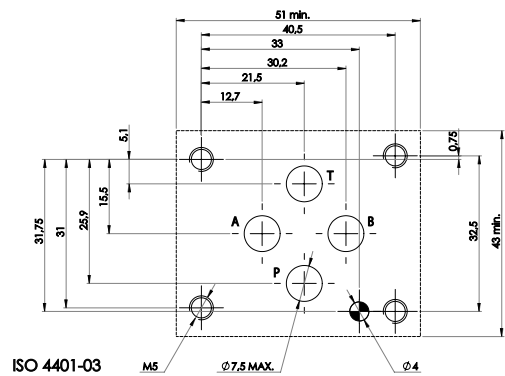
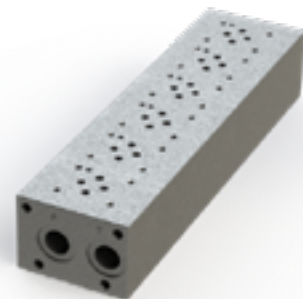

Type	Number of sections 03	Q max recommended (*) l/min
MRK-3-2 G	2	80 - 80
MRK-3-3 G	3	60 - 80
MRK-3-4 G	4	60 - 80
MRK-3-5 G	5	50 - 80
MRK-3-6 G	6	50 - 80
MRK-3-7 G	7	40 - 80
MRK-3-8 G	8	40 - 80

#### 4 INSTALLATION DIMENSIONS (mm)

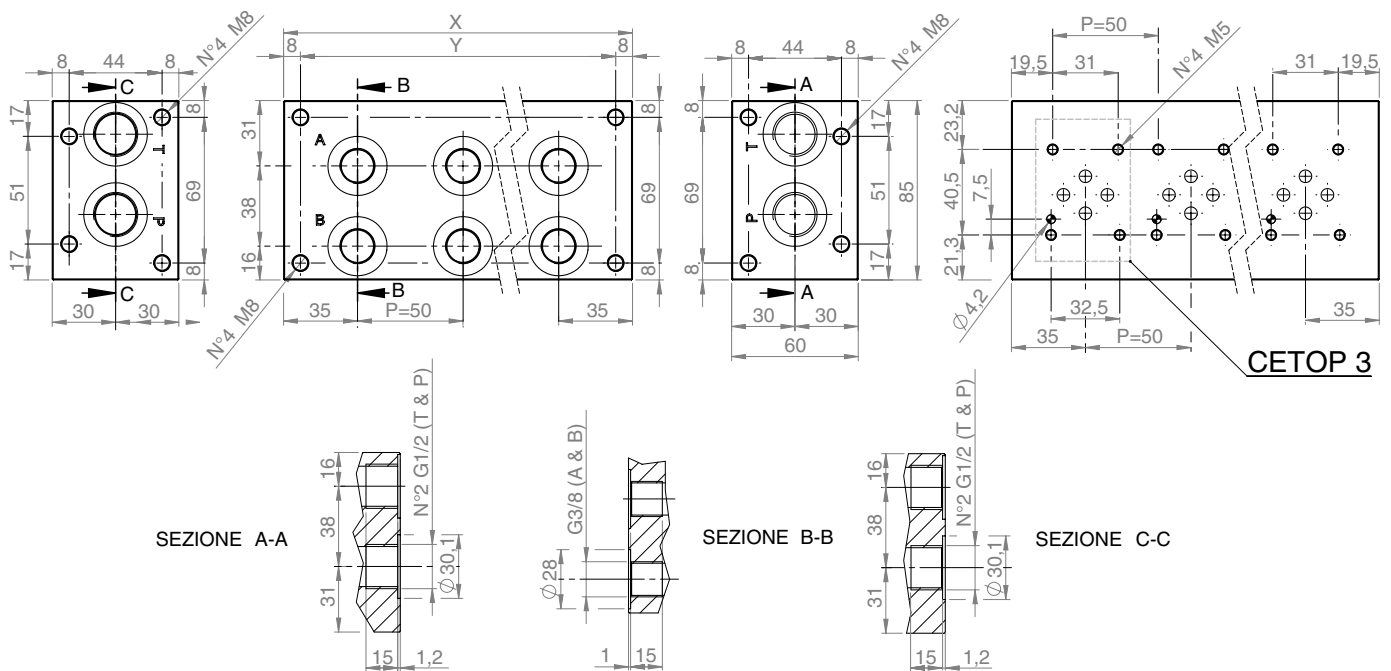

4 mounting holes threaded M8 on the rear side

#### 5 HYDRAULIC FLUID

Seals and materials used on standard valves MRK-3-\*G are fully compatible with hydraulic fluids of mineral oil base, upgraded with antifoaming and antioxidantizing agents. The hydraulic fluid must be kept clean and filtered to ISO 4406 class 19/17/14, or better, and used in a recommended viscosity range from 10 cSt to 60 cSt

Type	X (mm)	Z (mm)	mass (kg)
MRK-3-2G	120	104	3,90
MRK-3-3G	170	154	5,45
MRK-3-4G	220	204	7,00
MRK-3-5G	270	254	8,55
MRK-3-6G	320	304	10,10
MRK-3-7G	370	354	11,65
MRK-3-8G	420	404	13,20

#### 6 MOUNTING SURFACE OF THE VALVE:

Planarity of the surface: 0,01/100

Rugosity: Ra 0,8

Every section has a mounting surface according to ISO 4401-03.

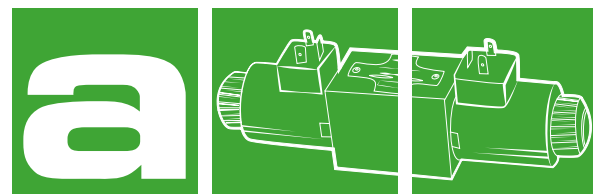

## MONOBLOCK SINGLE SECTION ISO 03 - BOTTOM PORTS

### MRSK-3-38G

80 l/min 35 MPa (350 bar)

#### 1 DESCRIPTION

MRSK-3-38 is a basic CETOP 3 baseplate useful for the connection of a single cetop section with A, B, P, T ports which are located in the bottom.

The plate is in steel phosphate coated.

#### 2 ORDERING CODE

(1)	(2)	(3)
MRSK	- 3	- 38G

MRSK: Base plate single section and bottom ports

3 : CETOP 3

38 : Ports with G3/8" threads

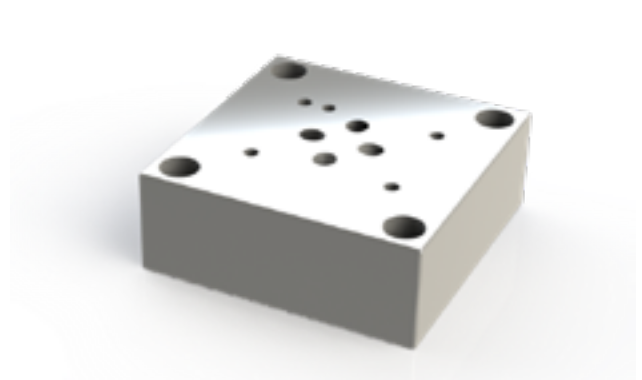

#### 3 TECHNICAL DATA

Material:	Steel
Coating	Phosphated
Max pressure	35 MPa (350 bar)
Max flow rate	80 l/min
Mass	1,24 kg

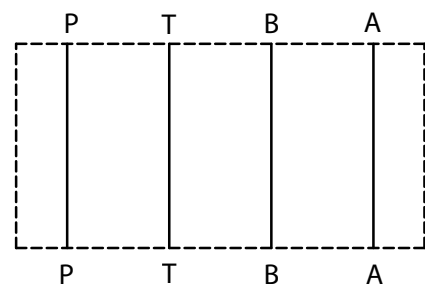

#### 4 INSTALLATION DIMENSIONS

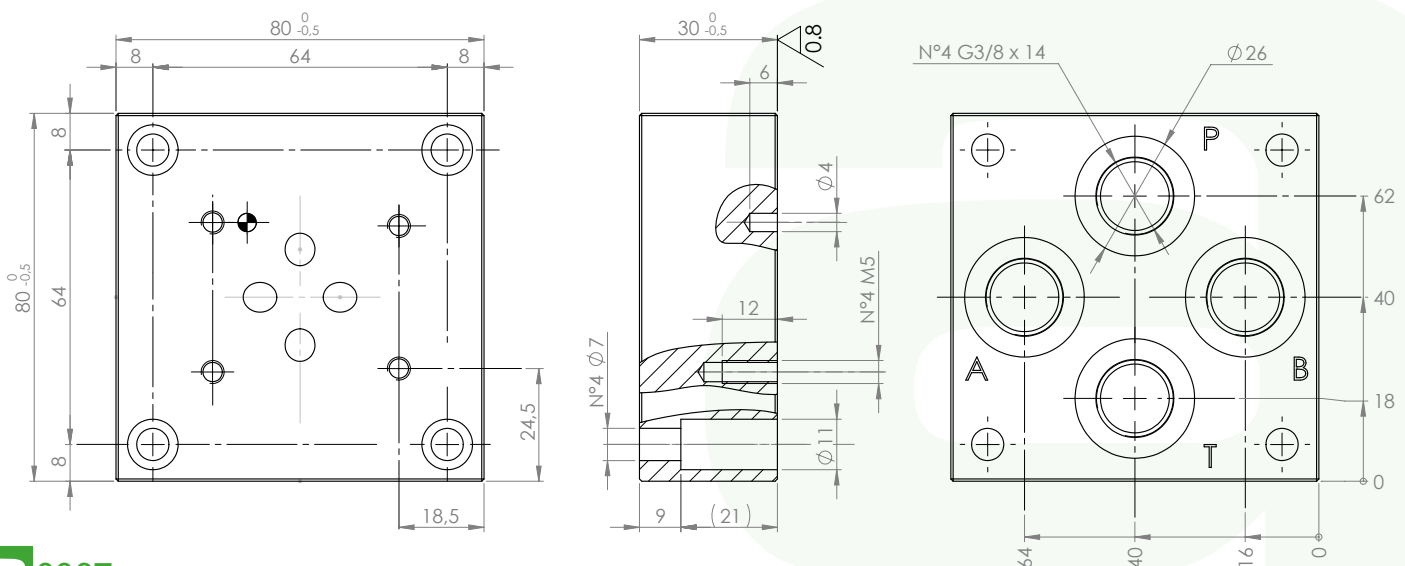



**5** OPTIONS

**RELIEF VALVE, DIRECTLY OPERATED**

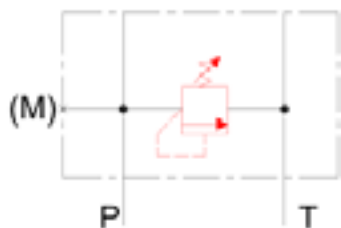

- 16: Pressure setting 50-116 bar
- 20: Pressure setting 110-220 bar
- 32: Pressure setting 200-320 bar

Example ordering code: BM3-G/20

**RELIEF VALVE, PILOT OPERATED**

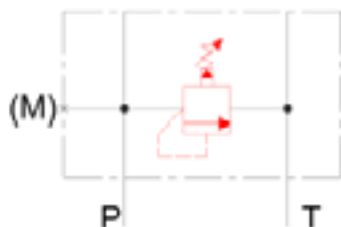

- 16: Pressure setting 50-116 bar
- 20: Pressure setting 110-220 bar
- 32: Pressure setting 200-320 bar

Example ordering code: BM3-G/P20

**RELIEF VALVE, ELECTRICALLY PROPORTIONAL PILOT OPERATED**

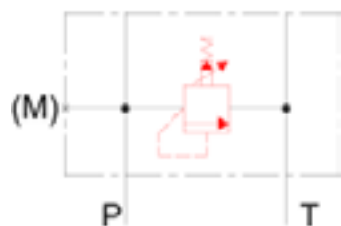

- PR12: Pressure up to 120 bar
- PR21: Pressure up to 210 bar
- PR35: Pressure up to 350 bar

Example ordering code: BM3-G/PR20

(\*) for more details about proportional valve see datasheet PMO\*-78

**BY-PASS ELECTRICALLY OPERATED VALVE**

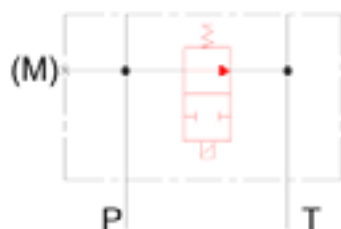

- NO: Normally open
- NC: Normally closed

Example ordering code: BM3-G/NO



## 6 INSTALLATION DIMENSIONS example

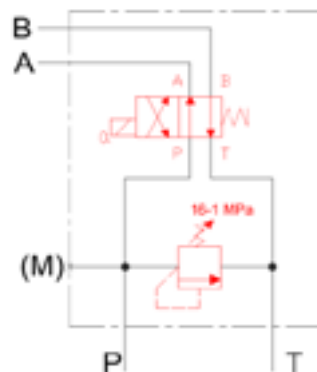
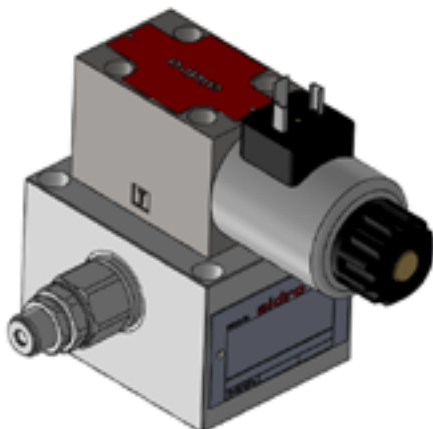
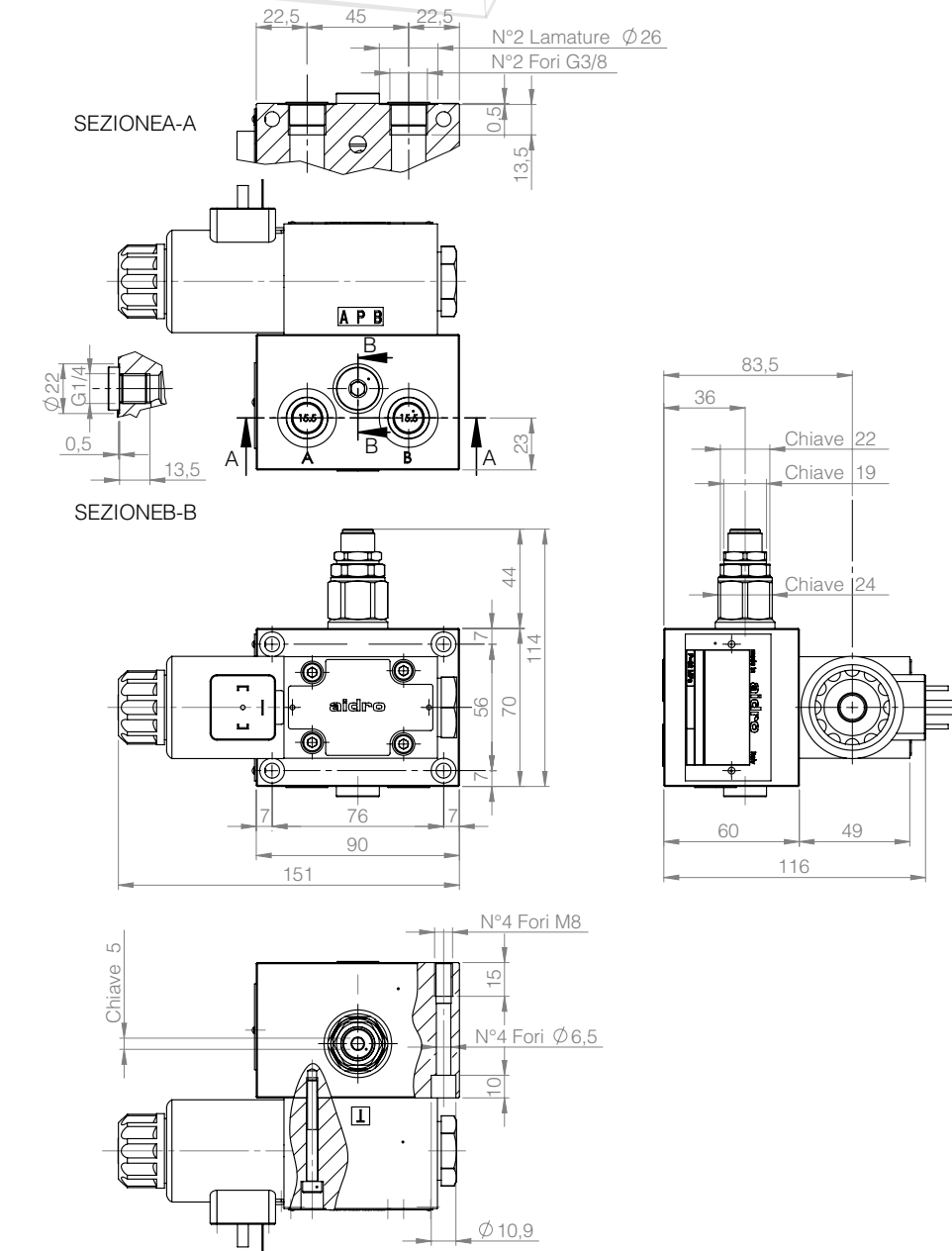



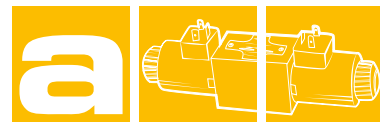

## **4** CETOP 05

DIRECTIONAL CONTROL VALVES SOLENOID OPERATED

**HD5-ES-\*** 0001

---

DIRECTIONAL CONTROL VALVES SOLENOID OPERATED

**HD5-ED-\*** 0006

---

STACKABLE VALVES FLOW CONTROL

**AM5-FC-\*** 0009

---

STACKABLE VALVES FLOW CONTROL

**AM5-FX-\*** 0011

---

STACKABLE CHECK VALVES

**AM5-CO-\*** 0013

---

STACKABLE CHECK VALVES

**AM5-CP-\*** 0015

---

STACKABLE VALVES PILOT OPERATED

**AM5-MP-\*** 0017

---

STACKABLE VALVES PRESSURE REDUCING

**AM5-RP-\*** 0019

---

MONOBLOCK WITH MULTIPLE SECTIONS ISO 05

**MR-5-\*G** 0021

---

MONOBLOCK WITH MULTIPLE SECTIONS ISO 05

**MR.K-5-\*G** 0023

---

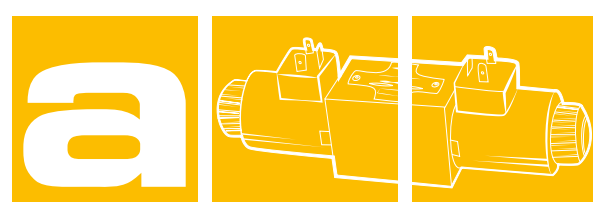

## DIRECTIONAL CONTROL VALVES SOLENOID OPERATED

### HD5-ES-\*

120 l/min 35 MPa (350 bar)

#### 1 DESCRIPTION

Valves HD5-ES are directional control valve with subplate mounting interface acc. to ISO 4401, DIN 24340 (CETOP 05).

The design of the body is a quality five chamber casting.

The valve is available with interchangeable metallic DC solenoids, also for AC power supply using a built-in rectifier bridge inside the coil.

In the standard version, the valve housing is phosphated for 240 h salt spray protection acc. to ISO 9227. Enhanced surface protection for mobile sector available (ISO 9227, 520 h salt spray).



#### 2 ORDERING CODE

(1)	(2)	(3)	(4)	(5)	(6)
HD5	-	ES	-	-	/ 20

(1) HD5 : 4-way directional control valve CETOP 05 – Pressure 32 MPa (320 bar)

(2) ES : electrically controlled, standard

(3) Spool type (see 4)

-number is the main spool type

-letter is the solenoid or spring arrangement:

C : 2 sol. , spool is spring centered (3 position)

N : 2 sol. , spool is detented (2 position)

LL : 1 sol. (a), spool is spring offset (2 pos. , end to end)

ML: 1 sol. (a), spool is spring centered (2 pos. , middle to end)

LM: 1 sol. (a), spool is spring offset (2 pos. , end to middle)

(4) Code reserved for special variants:

b: only for version LL, ML, LM, solenoid b installed (instead of a)

T\* : soft shifting device (see 12 and 13)

K : water proof caps on override pin (see 14)

Z\* : anti-corrosion variants (see 16)

DR: solenoid(s) chamber draining (see 15)

(5) Electric voltage and solenoid coils (see 8, 9, 10)

(6) 20: design number (progressive) of the valve

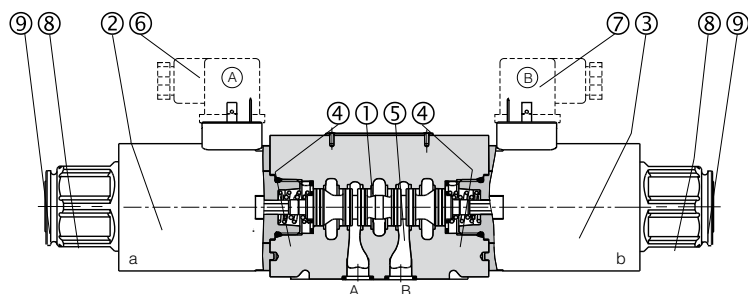
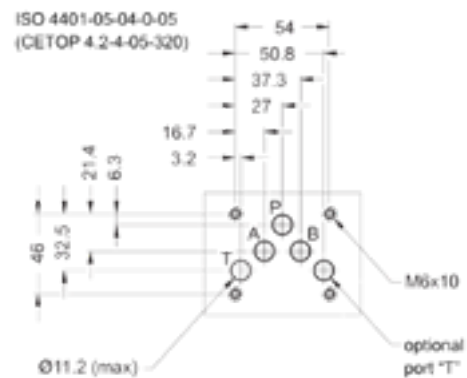

The spool 1 shifts into the valve body 7 subject to the action of springs and solenoids 2 and 3. Spool 1, depending from its shape and its position in the valve body 7, opens and/or closes passages between P, A, B and T ports, thus controlling the direction of the hydraulic flow. In case of electric cut-offs the spool can be manually shifted by acting on the override pins 9, located at the end of the solenoids and accessible through the retaining nuts.

### 3 TECHNICAL DATA

Nominal flow	120 l/min
Max. rec. flow	see 5
Nominal pressure (P, A,B)	32 MPa (320 bar)
Max. rec. Pressure (P, A, B)	35 MPa (350 bar)
Max. rec. Pressure (T port)	21 MPa (210 bar)
Pressure drops	see 6
Protection to DIN 40050	IP 65
Duty cycle	100 %
Service life	> 10 <sup>7</sup> cycles
Mass	1 sol. 3,9 kg 2 sol. 5,4 kg

### 4 SPOOL IDENTIFICATION AND INTERMEDIATE POSITION TRANSITORIES

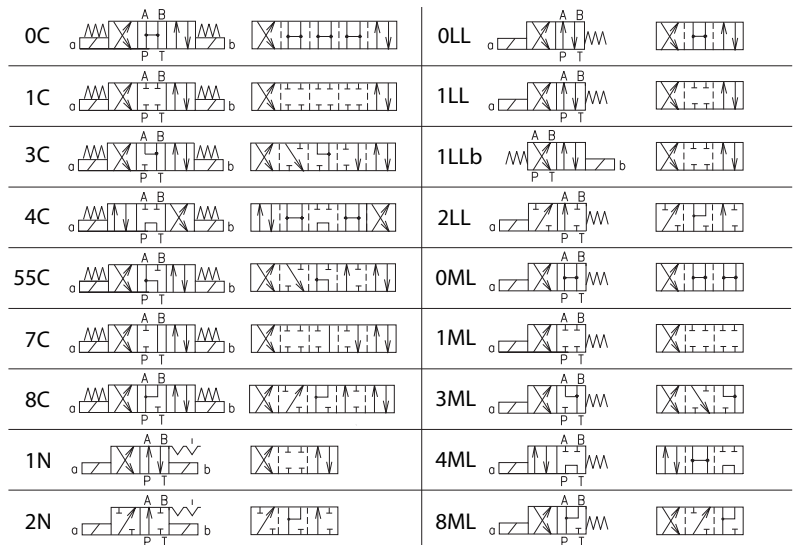

### 5 TYPICAL DIAGRAMS

Typical  $\Delta p$  curves for valves HD5-ES-\*, with mineral oil at  $v=32 \text{ mm}^2/\text{s}$  and  $t=40^\circ\text{C}$ , for flow P -> A/B, A/B -> T and P -> T

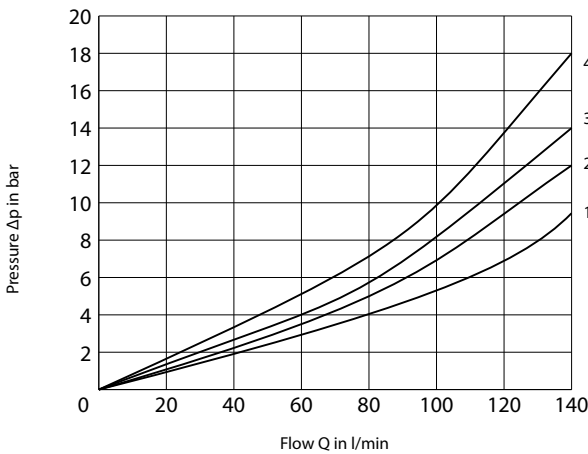

Spool type	P-A	P-B	A-T	B-T	P-T
0C	1	1	2	2	1
1C	1	1	2	2	-
3C	1	1	2	2	-
4C	3	3	4	4	1
55C	1	1	1	2	2
7C	1	1	2	2	-
8C	1	1	2	2	-
1N	1	1	2	3	-
2N	1	1	-	-	-
0LL	1	1	1	3	-
1LL	1	1	2	2	-
1LLb	1	1	2	2	-
2LL	1	1	-	-	-
0ML	-	1	2	-	1
1ML	-	1	2	-	-
3ML	-	1	2	-	-
4ML	3	-	-	4	1
8ML	-	1	2	-	-

### 6 HYDRAULIC LIMIT OF USE

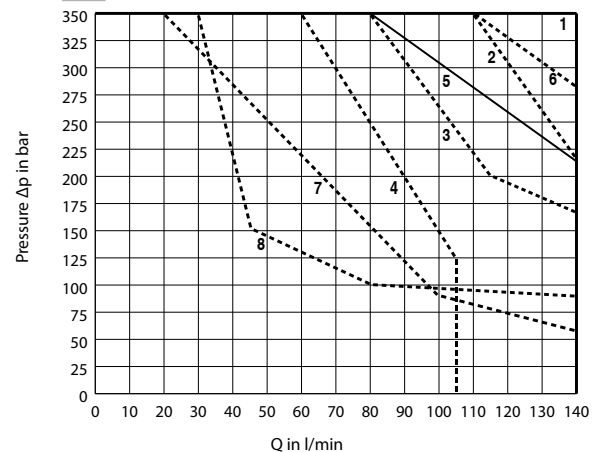

Spool type	Limit
0C	1
1C	
8C	
0ML	
1ML	5
8ML	
3C	
3ML	3
4C	
55C	7
7C	
1N	4
2N	
0LL	8
1LL	
1LLb	2
2LL	
4ML	3

## 7 INSTALLATION DIMENSION (mm)

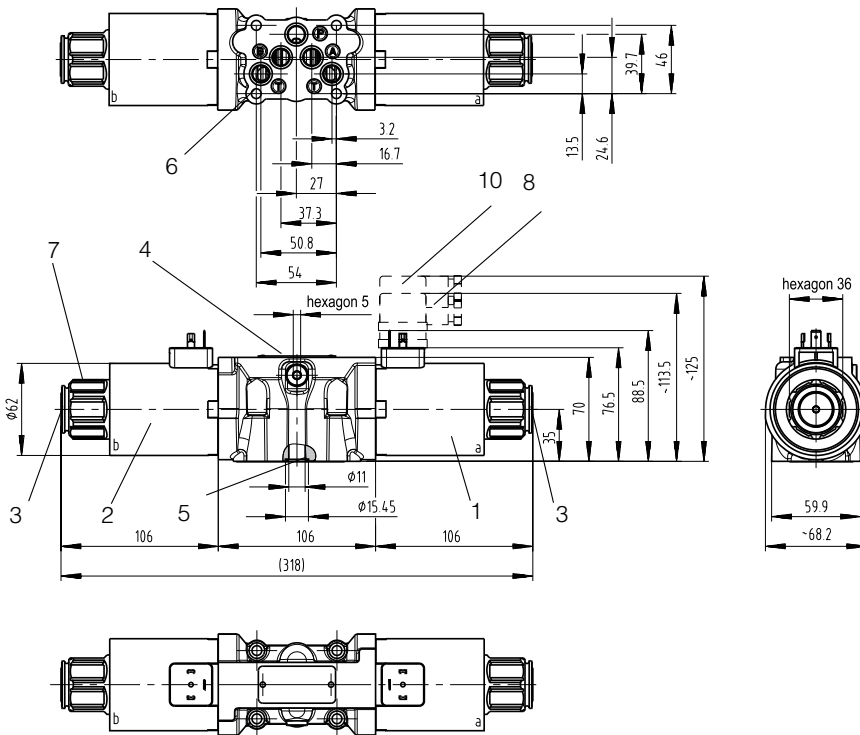

All valves HD5-ES-\* conform with ISO and CETOP specifications for mounting surface dimensions and for valves height.

When assembled to its mounting plate, valve HD5-ES-\* must be fastened with 4 fixing bolts (socket head screws to ISO 4762) M6 x 40 mm (or M6 x\* according to the number of modules) of class 12,9 (ISO898) tightened at 12 Nm torque.

Leakage between valve and mounting surface is prevented by the positive compression on their seats of 5 seals of Quad-Ring type 12,42 x 1,68 x 1,68 mm.

## 8 SOLENOID COILS, WITH STANDARD ELECTRIC CONNECTION TO ISO 4400 / DIN 43650, FOR DC SUPPLY

Standard valves type HD5-ES-\* are operated by solenoid that are energized directly from a D.C. voltage supply. Solenoid valves can be supplied without electric coils as HD5-ES\*-0000 and coils can be supplied separately as B05-\*\*\*C.

Directly from D.C. supply			
Voltage	Valve Code	Coil Code	Nominal Current (A)
V 12 DC	HD5-ES-*-*-012C	B05-012C	3,17
V 24 DC	HD5-ES-*-*-024C	B05-024C	1,73

Permissible supply voltage variation : +5% -10%  
Special voltages available : V 48 DC, V 106 DC, V 205 DC

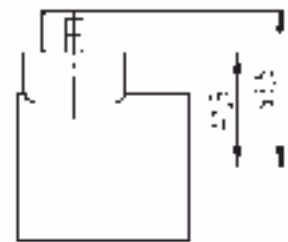

## 9 SOLENOID COILS, WITH STANDARD ELECTRIC CONNECTION TO ISO 4400 / DIN 43650, FOR AC SUPPLY

Valves type HD5-ES-\* can be operated from A.C. supply by the use of coils that incorporate a full wave bridge rectifier. Coils with rectifier can be supplied separately as B05-\*\*\*A.

Directly from A.C. supply			
Voltage	Valve Code	Coil Code	Nominal Current (A)
V 115 AC / 50 (60) Hz	HD5-ES-*-*-115A	B05-115A	0,40
V 230 AC / 50 (60) Hz	HD5-ES-*-*-230A	B05-230A	0,20

Permissible supply voltage variation : +5% -10%  
Special voltages available : V 48 DC, V 106 DC, V 205 DC

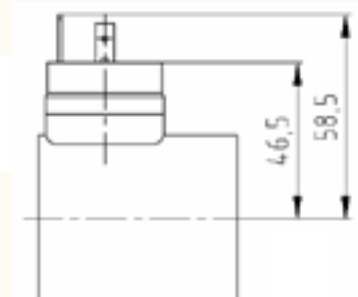

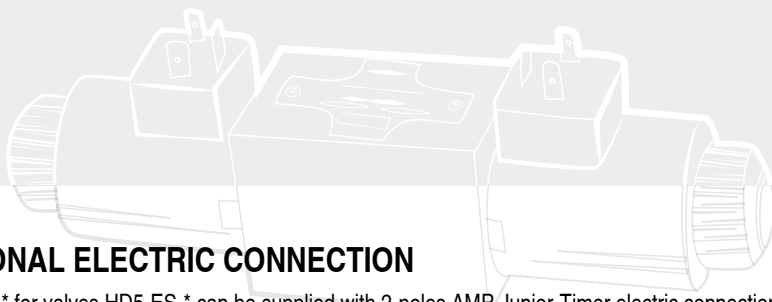

## 10 OPTIONAL ELECTRIC CONNECTION

Coils type B05-\* for valves HD5-ES-\* can be supplied with 2-poles AMP Junior-Timer electric connection. Coils with AMP connection can be supplied separately as B05-\*\*\*CAMP

AMP electric connection			
Voltage	Valve Code	Coil Code	Nominal Current (A)
V 12 DC	HD5-ES-*-*-012 CAMP	B05-012CAMP	3,17
V 24 DC	HD5-ES-*-*-024 CAMP	B05-024CAMP	1,73

Other optional electric connection are available :

- Flying Leads
- Flying Leads (250 mm) with Deutsch connection (DT04-2P)

## 11 VERSION "N" : MECHANICAL DETENT ON SPOOL

Solenoids valves with detent typically are 2 position, 2 solenoid, no-spring valves where the spool is kept at the extreme ends of its stroke by a mechanical device. This permits that solenoids are energized by short time current pulses and the spool remains at its position regardless of forces due to hydrodynamics or gravitational/inertial effects (vibrations).

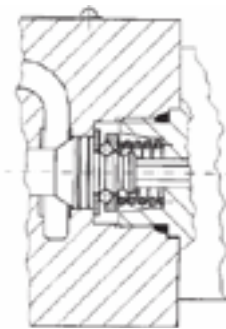

## 12 VERSION "T": SOFT SHIFTING

Solenoid valves with soft shifting devices are 2 or 3 position valves which incorporated a fixed throttling orifice ( $\varnothing$  0,6 mm) on the channel that connects the extreme hydraulic chambers of the valve. The throttling effect controls the spool shifting time, thus limiting unwanted hydraulic shocks.

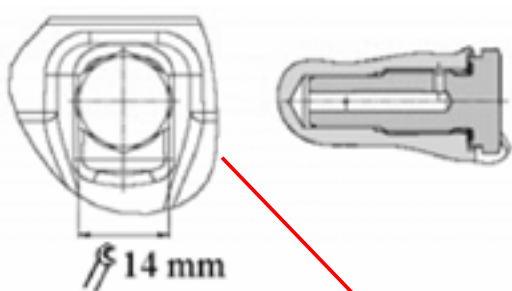

## 13 VERSION "TR": ADJUSTABLE SOFT SHIFTING

In Version "TR" valves, the fixed orifice is replaced by an adjustable, variable throttle valve that permit a fine and precise adjustment of the spool shifting time. To increase the throttling (and therefore the shifting time) turn clock-wise the adjusting screw (Ch. 3 mm), after having unlocked its retaining nut (Ch. 10 mm).

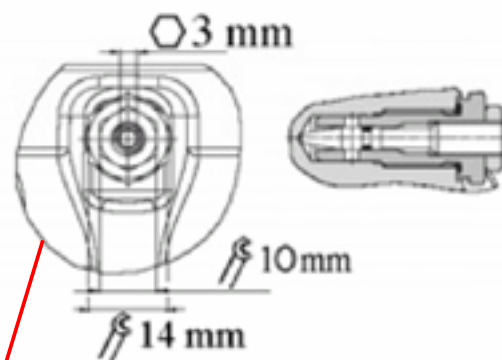

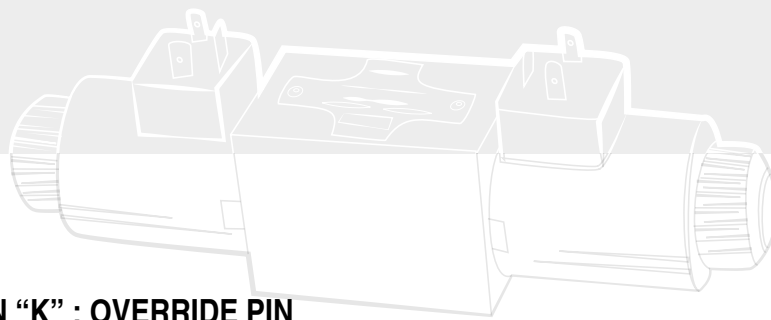

#### 14 VERSION "K" : OVERRIDE PIN

Solenoid valves according to "K" version have override actuators that push on the valve's override pins and permit a quick and easy "hand operation" of the valves, without the need of any tool. The override actuator is incorporated in a flexible rubber cap that is easily applicable on the solenoid retaining nuts and that protects from moisture and water splashes.

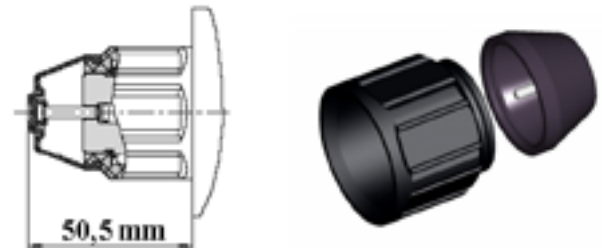

#### 15 VERSION "DR" : SEPARATE DRAINING OF THE SOLENOID CHAMBER

Solenoid valves according to "DR" version present a draining line of the chambers of the solenoids. This version should be adopted in presence of high counterpressure on T line that exceed the permissible recommended maximum pressure for T ports of the valve (210 bar). Position of additional draining port DR is conform with ISO 4401-05 interface and correspond to the Y port.

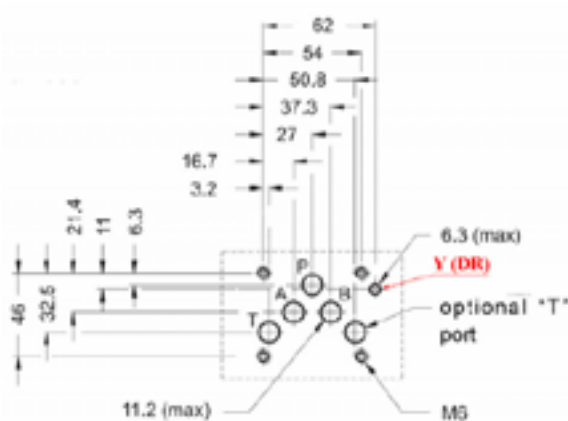

Dimensioni in mm

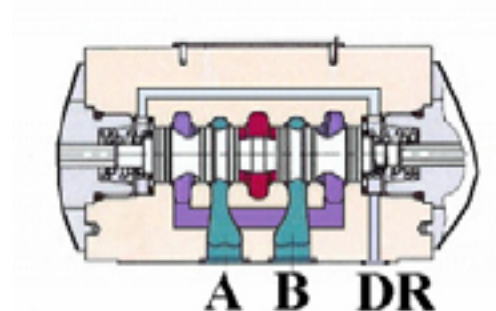

#### 16 ANTICORROSION OPTIONS

On HD5-ES-\* standard valves the body is phosphate coated, the solenoid tubes are not treated and coils mantel and irons are zinc trivalent plated. To increase the resistance to corrosive agents different variants are available :

ZT : • Body, solenoid tubes and coils irons are zinc trivalent plated

ZL : • Body is coated with special TEMADUR 40 zinc painting  
• Solenoids have 8-12 µm zinc plating

ZK : • Body is coated with special TEMADUR 40 zinc painting  
• Solenoids tube and coils irons are "zinc-nickel" plated



Example of ZK painted valve : HD5-ES-1LLb-ZK-024C/20



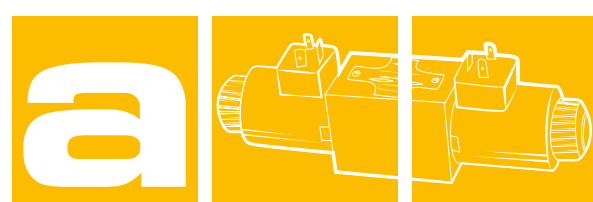

## DIRECTIONAL CONTROL VALVES SOLENOID OPERATED

### HD5-ED-\*

125 l/min 32 MPa (320 bar)

#### 1 DESCRIPTION

Valves HD5-ED are directional control valve with subplate mounting interface acc. to ISO 4401, DIN 24340 (CETOP 05).

The valve is designed for low performance applications when you need a CETOP 5 interface but limited flow rates.

The valve is available with interchangeable metallic DC solenoids, also for AC power supply using a built-in rectifier bridge inside the coil.

In the standard version, the valve housing is phosphated for 240 h salt spray protection acc. to ISO 9227.

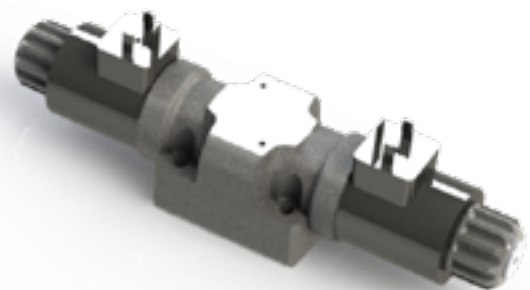

#### 2 ORDERING CODE

(1)	(2)	(3)	(4)	(5)	(6)	(7)
HD5	-	ED	-	-	-	/ 10

(1) HD5 : 4-way directional control valve CETOP 05

(2) ED : electrically controlled

(3) Spool type (see 4)

-number is the main spool type

-letter is the solenoid or spring arrangement:

C : 2 solenoid , spool is spring centered (3 position)

LL : 1 solenoid, spool is spring offset (2 position)

ML: 1 solenoid, spool is spring centered (2 position)

(4) Code reserved for special variants

(5) Electric voltage and solenoid coils:

0000: no coil(s)

012C: coil(s) for 12 V DC

024C: coil(s) for 24 V DC

115A: coil(s) for 110/50 V AC- 115/60 V AC

230A: coil(s) for 220/50 V AC - 230/60 V AC

(6) Coil connection:

no designation: DIN 43650-A ISO 4400

AMP: Amp Junior Timer - vertical configuration

AMPX: Amp Junior Timer - axial configuration

D: Deutsch

(7) Design number (progressive) of the valve

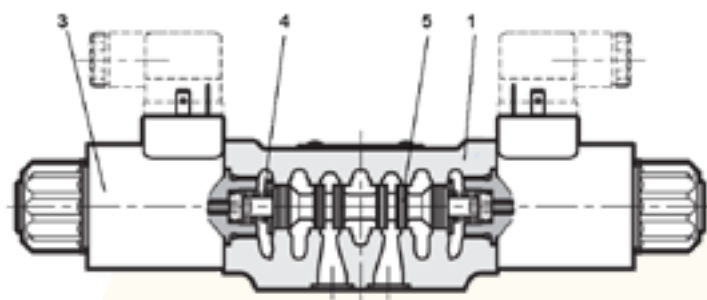
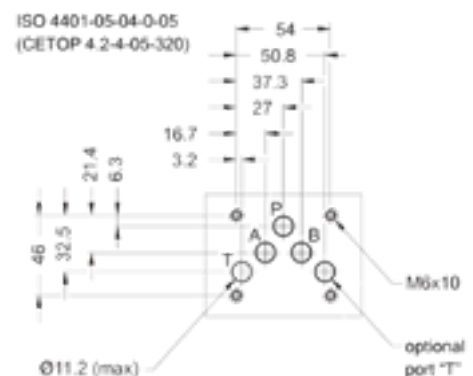

The spool 5 shifts into the valve body 1 subject to the action of springs 4 and solenoids. Spool 5, depending from its shape and its position in the valve body 1, opens and/or closes passages between P, A, B and T ports, thus controlling the direction of the hydraulic flow.

## 3 TECHNICAL DATA

Nominal flow	100 l/min	<b>Electric characteristics:</b> Valve type HD5-ED-* are operated by solenoid that are energized: - directly from a DC voltage supply 24 V DC = 024C 12 V DC = 012C - by the use of coils that incorporate a full wave rectifier, from AC voltage supply: 115A110/50 V AC- 115/60 V AC = 115A 220/50 V AC - 230/60 V AC = 230A All connectors must conform to ISO 4400 (DIN 43650) and electric circuitry must be able to carry the following rated current values : V 12 DC = 2,4 A V 115/50 = 0,26 A V 24 DC = 1,2 A V 230/50 = 0,14 A Coils with 2 electric pins, conforming with AMP connectors, are only available for DC supply (example of code : B03-012C AMP). Permissible supply voltage variation : ± 10 %
Maximum rec. flow rate see	125 l/min	
Maximum nominal pressure (P,A,B)	32 MPa (320 bar)	
Maximum pressure at T port	21 MPa (210 bar)	
Pressure drops	see 5	
Energizing switching times	70-100 ms	
Protection to DIN 40050	IP 65	
Duty cycle	100%	
Installation and dimensions	see 7	
Mass	3,0/2,4 kg	

## 4 SPOOL IDENTIFICATION AND INTERMEDIATE POSITION TRANSITORIES

1C			1ML		
4C			0ML		
0C			1MLb		
3C			1LLb		
1LL			4MLb		
3ML			0MLb		
4ML			3MLb		

## 5 TYPICAL DIAGRAMS

Typical P-Q curves for valves HD5-ED-\* in standard configuration, with mineral oil at  $v=32 \text{ mm}^2/\text{s}$  and at  $T=40^\circ\text{C}$ .

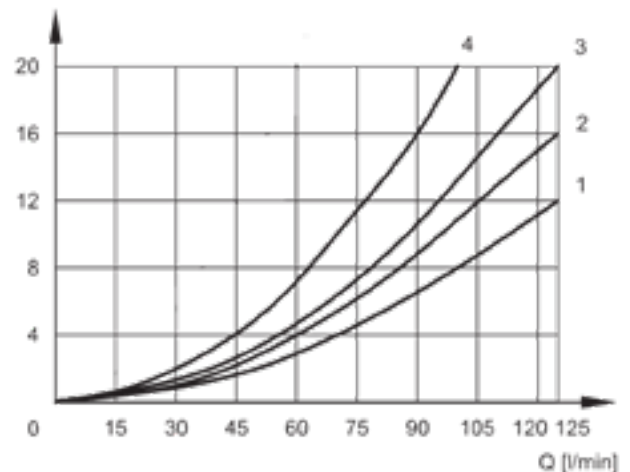

## 6 HYDRAULIC LIMIT OF USE

P-Q characteristics limits for safe use of HD5-ED-\* solenoid operated valves. Measured at  $v=32 \text{ mm}^2/\text{s}$  and  $T = 40^\circ\text{C}$

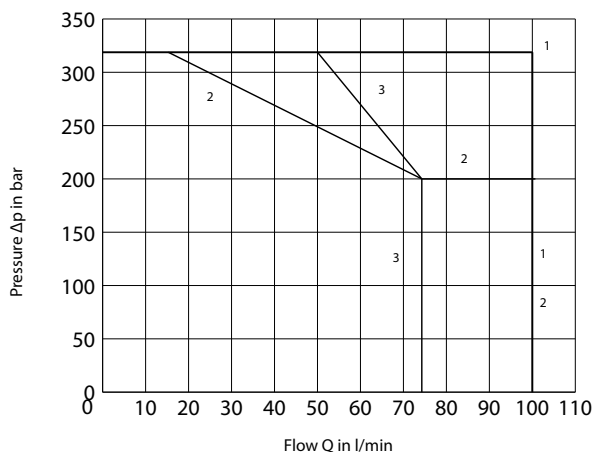

1C	1
4C	3
0C	1
3C	2
1LL	1
3ML	2
4ML	3
1ML	1
1MLb	1
1LLb	1
4MLb	3

Spool	P-A	P-B	A-T	B-T	P-T
1C	1	1	2	2	
4C	4	4	4	4	1
0C	1	1	1	1	1
3C	1	1	1	1	
1LL	2	2	3	3	
1LLb	2	2	3	3	

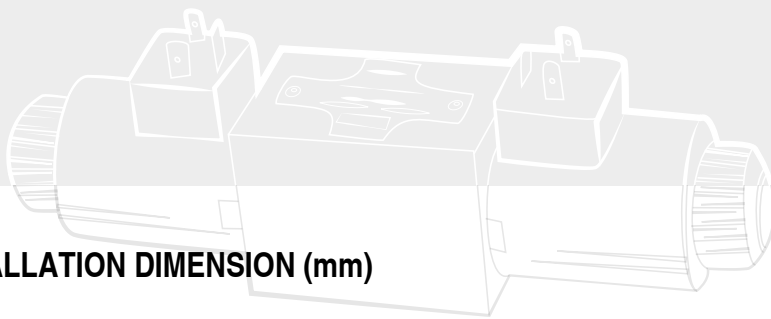

## 7 INSTALLATION DIMENSION (mm)

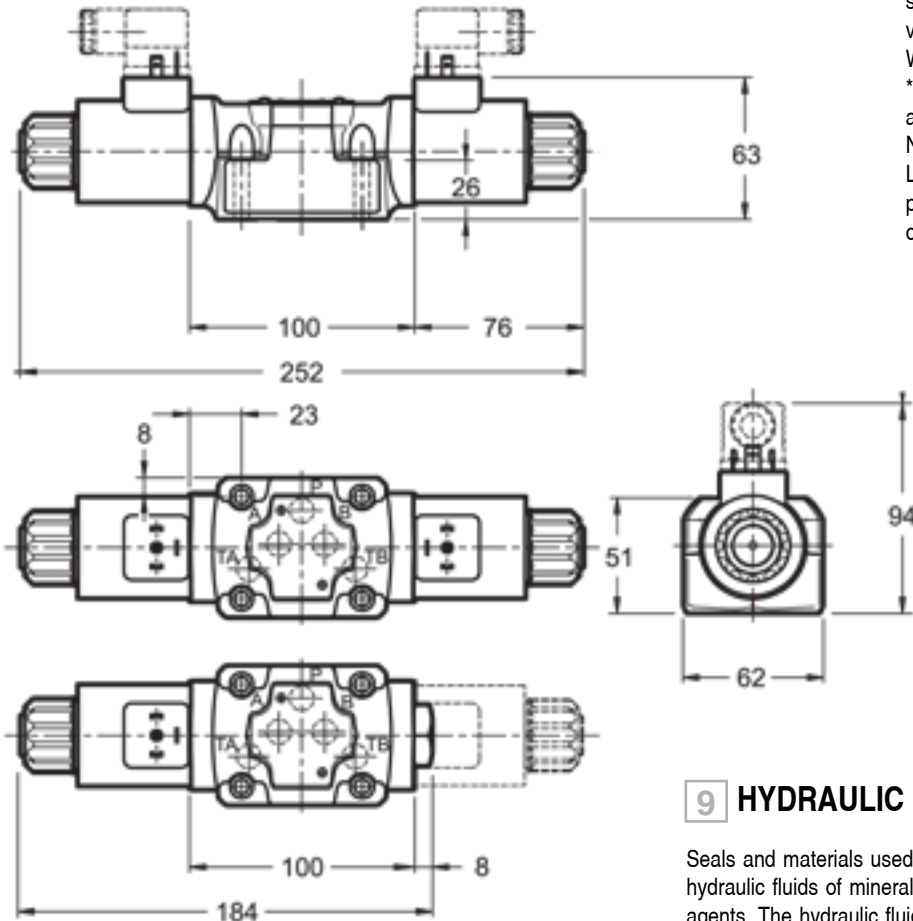

All valves HD5-\* conform with ISO and CETOP specifications for mounting surface dimensions and for valves height.

When assembled to its mounting plate valve HD5-\* must be fastened with 4 bolts M6x35 (or M6x\*\* according to the number of modules) tightened at 12 Nm torque.

Leakage between valve and mounting surface is prevented by the positive compression on their seats of 5 seals of O Ring type 12,42x1,78 - 90 Shore.

## 8 SOLENOID

Solenoid valves can be supplied without electric coils, as HD5-ED-\*\*\*-0000. Coils are ordered separately ; standard, 3 electric pins, coils are :

- B03-024C ; B03-012C
- B03-115A ; B03-230A

Connections to the electric supply is made by standard 3-PIN connectors, according to ISO 4400 (DIN 43650). Connectors can be with different cable exit size (PG9, PG11) and beside of the plain connecting function they may incorporate various features like

- Signal led
- Voltage surge suppressor, etc.

## 9 HYDRAULIC FLUID

Seals and materials used on standard valves HD5-\* are fully compatible with hydraulic fluids of mineral base, upgraded with antifoaming and anti oxidizing agents. The hydraulic fluid must be kept clean and filtered to ISO 4406 class 19/17/14, or better, and used in a recommended viscosity range from 10 cSt to 60 cSt.

## 10 MANUAL OVERRIDE

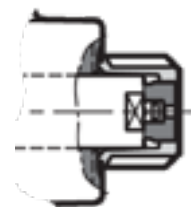

In case of electric cut-offs, the spool can be manually shifted by acting on the emergency pins, located at the end of the solenoids and accessible through the retaining nuts.

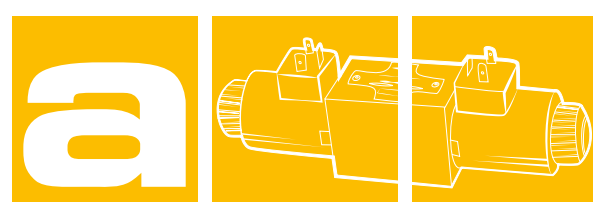

## STACKABLE VALVES FLOW CONTROL

### AM5-FC-\*

100 l/min 32 MPa (320 bar)

#### 1 DESCRIPTION

Stackable valve CETOP 5 with meter out control (referred to the hydraulic actuator). It is possible to control the lines A, B or AB simply turning the side screws.

On demand it is possible to have also the fine control option.



#### 2 ORDERING CODE

(1)	(2)	(3)	(4)	(5)	(6)
AM5	-	FC	-	-	/ 10

(1) AM5 : stackable valve CETOP 05 - Pressure 32 MPa (320 bar)

(2) FC : one-way flow control valves with meter-out control (referred to the hydraulic actuator)

(3) Service lines where the controls operates:  
 AB : controls on A and B. Fluid flows unrestricted A->A1 and B->B1;  
 flow is controlled from A1->A and B1->B.  
 A : flow is controlled from A1->A; free on B.  
 B : flow is controlled from B1->B; free on A.

(4) flow control characteristics for A1->A and B1->B  
 and check valve opening pressure (Pm) for flow A ->A1 and B->B1  
 no designation : standard control and Pm approx 0.04 MPa (0.4 bar)  
 V : fine control  
 4 : Pm approx 0.4 MPa (4 bar)

(5) Code reserved for special variants

(6) Design number (progressive) of the valve

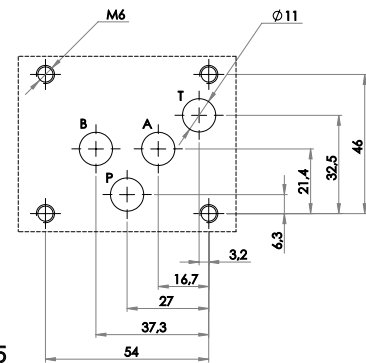

ISO 4401-05

AM5-FC-AB

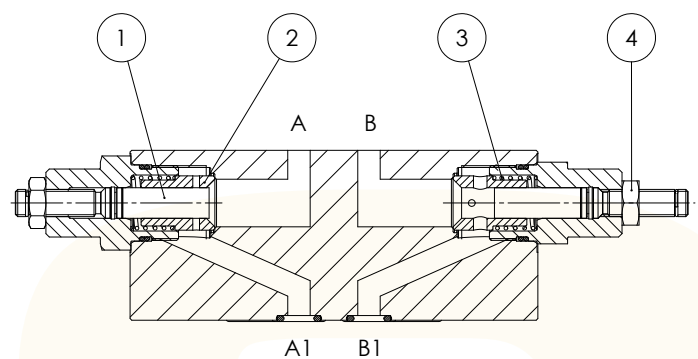

Fluids flows freely on P and T lines: on service lines A and/or B with controls, fluid flows from A -> A1 (and/or B-> B1) overcoming the force of spring 3 acting on sleeve 2; fluid flows from A1-> A (and/or B1->B) through orifices to sleeve 2 which is pushed against its seat; the throttling axis 1, which is shifted by screwing it and locked by its nut 4, partially obstructs the control orifices, thus making the flow rate entirely dependent upon the available pressure drop.

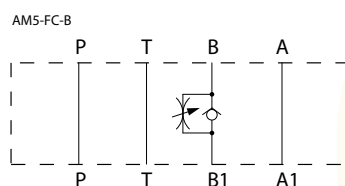
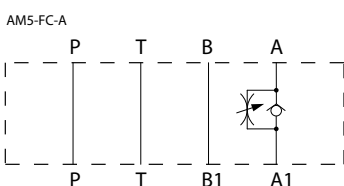
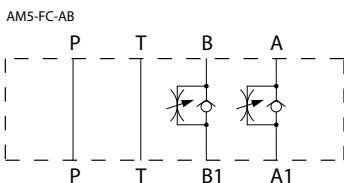

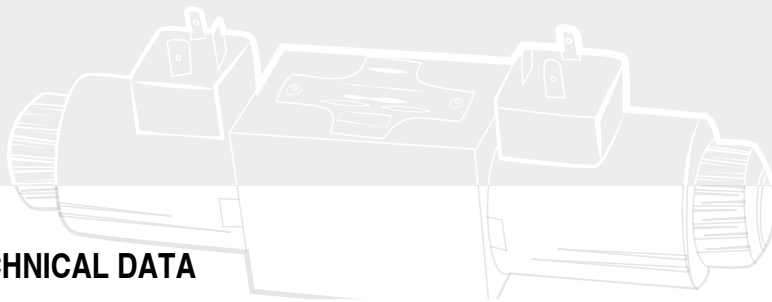

### 3 TECHNICAL DATA

Maximum rec. flow rate	100 l/min	Control of the flow:
Maximum nominal pressure	32 MPa (320 bar)	The control is made by throttling from A1->A (and/or B1->B), through variable orifices. Depending on the various sleeve/axis combination, the control adjustment is:
Pressure drops	see 4	- (standard) : orifices area is reduced from 100% (*) to 0% with 6 complete turns of the adjustment screw.
Installation and dimensions	see 6	-V (fine): from 100% (**) to 0% with 5 complete turns of the adjustment screw.
mass	approx 3 kg	(*) 100% approx: Q=60 l/min at p=20 bar
		(**) 100% approx : Q=30 l/min at p=20 bar
		The axis is shifted to increase throttling by unlocking its nut and turning clock wise the adjustment screw. Suitable mechanical stops prevent dangerous manoeuvring.

### 4 TYPICAL DIAGRAMS

Typical  $\Delta p$ -Q curves for valves AM5-FC-AB in standard configuration, with mineral oil at 36 cSt and at 50°C with throttling axis at full retraction.

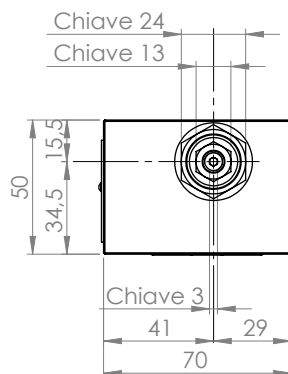
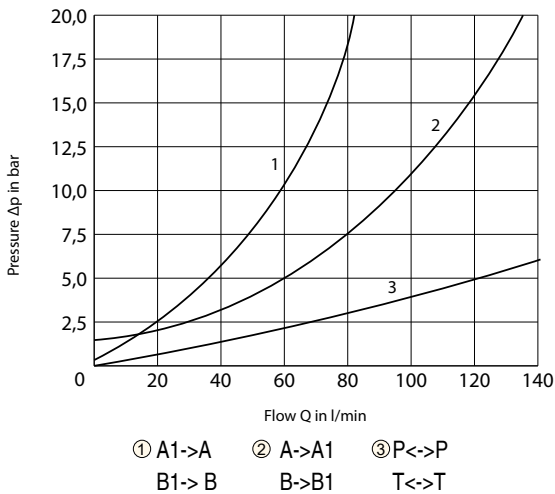

All stackable valves AM5-FC-\* conform with ISO and CETOP specifications for mounting surface dimensions (see also front page). Valves height 50 mm. Leakage between valve and mounting surface is prevented by the positive oppression on their seats of 4 seals of OR type or Quading type.

### 5 HYDRAULIC FLUIDS

Seals and materials used on standard valves AM5-\* are fully compatible with hydraulic fluids of mineral oil base, upgraded with antifoaming and antioxidanting agents. The hydraulic fluid must be kept clean and filtered to ISO 4406 class 19/17/14, or better, and used in a recommended viscosity range from 10 cSt to 60 cSt.

### 6 INSTALLATION DIMENSIONS

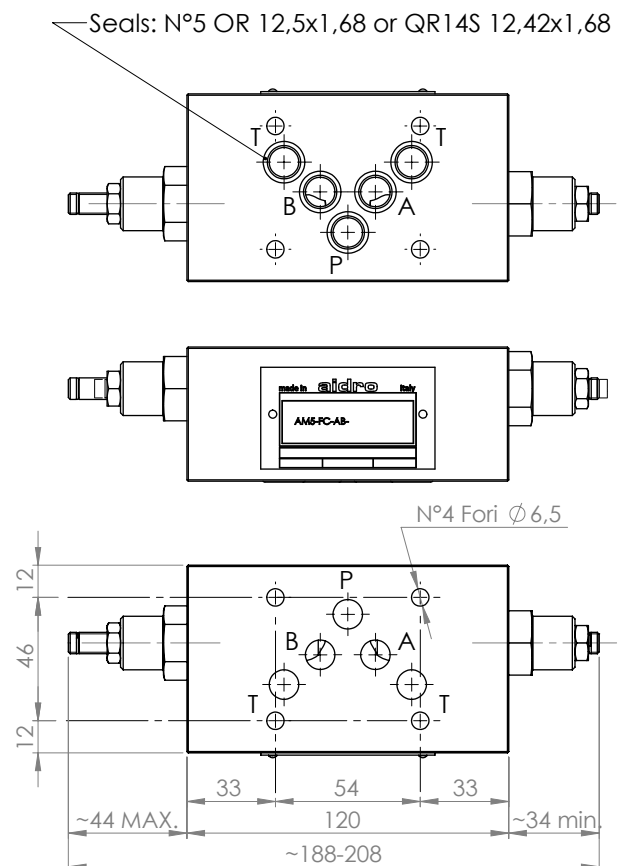

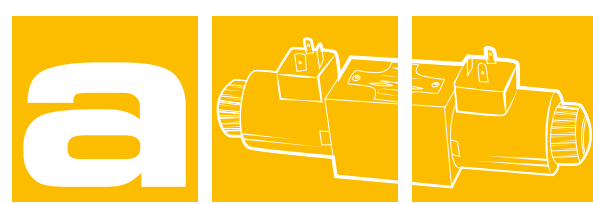

## STACKABLE VALVES FLOW CONTROL

### AM5-FX-\*

100 l/min 32 MPa (320 bar)

#### 1 DESCRIPTION

Stackable valve CETOP 5 with meter in control (referred to the hydraulic actuator). It is possible to control the lines A, B or AB simply turning the side screws.

On demand it is possible to have also the fine control option.



#### 2 ORDERING CODE

(1)	(2)	(3)	(4)	(5)	(6)
AM5	-	FX	-	-	/ 10

(1) AM5 : stackable valve CETOP 05 - Pressure 32 MPa (320 bar)

(2) FC : one-way flow control valves with meter-out control (referred to the hydraulic actuator)

(3) Service lines where the controls operates:

AB : controls on A and B. Fluid flows unrestricted A->A1 and B->B1; flow is controlled from A1->A and B1->B.

A : flow is controlled from A1->A; free on B.

B : flow is controlled from B1->B; free on A.

(4) flow control characteristics for A1->A and B1->B (see also [6]) and check valve opening pressure (Pm) for flow A->A1 and B->B1 no designation : standard control and Pm approx 0.04 MPa (0.4 bar)

V : fine control

4 : Pm approx 0.4 MPa (4 bar)

(5) Code reserved for special variants

(6) Design number (progressive) of the valve

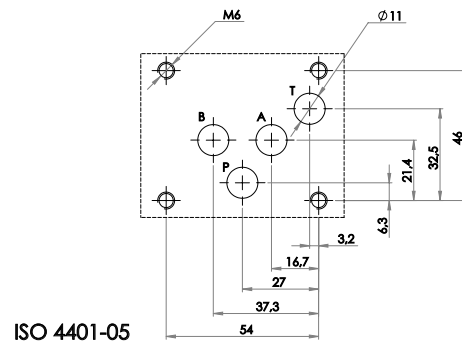

ISO 4401-05

#### AM5 - FX - AB

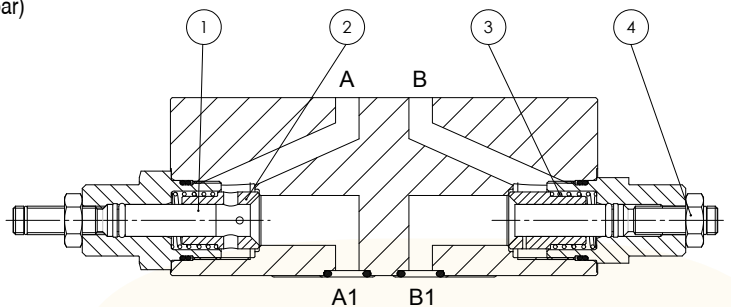

Fluid flows freely on P and T lines; on service lines A and/or B with controls, fluid flow from A1->A (and/or B1->B) overcoming the force of spring acting on sleeve; fluid flows from A->A1 (and/or B->B1) through orifices of sleeve which is pushed against its seat; the trotling axis, which is shifted by screwing it and locked by its nut, partially obstructs the control orifices, thus making the flow rate entirely dependent upon the available pressure drop.

AM5-FX-AB

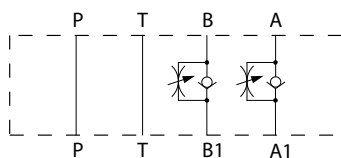

AM5-FX-A

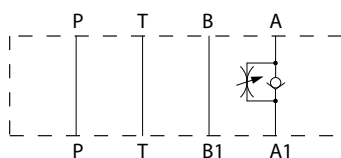

AM5-FX-B

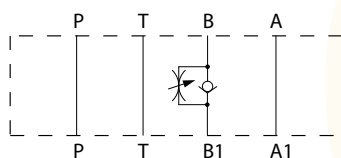

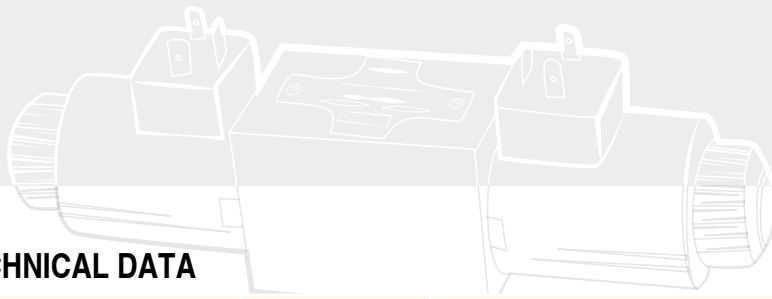

### 3 TECHNICAL DATA

Maximum rec. flow rate	100 l/min	<b>Control of the flow:</b> The control is made by throttling from A1->A (and/or B1->B), through variable orifices. Depending on the various sleeve/axis combination, the control adjustment is: - (standard) : orifices area is reduced from 100% (*) to 0% with 6 complete turns of the adjustment screw. -V (fine): from 100% (**) to 0% with 5 complete turns of the adjustment screw. (*) 100% approx: Q=60l/min at $\Delta p=20$ bar (**) 100% approx: Q=30l/min at $\Delta p=20$ bar The axis is shifted to increase throttling by unlocking its nut and turning clock wise the adjustment screw. Suitable mechanical stops prevent dangerous manoeuvring.
Maximum nominal pressure	32 MPa (320 bar)	
Pressure drops	see 4	
Installation and dimensions	see 6	
mass	approx 3 kg	

### 4 TYPICAL DIAGRAMS

Typical  $\Delta p$ -Q curves for valves AM5-FX-AB in standard configuration, with mineral oil at 36 cSt and at 50°C with throttling axis at full retraction.

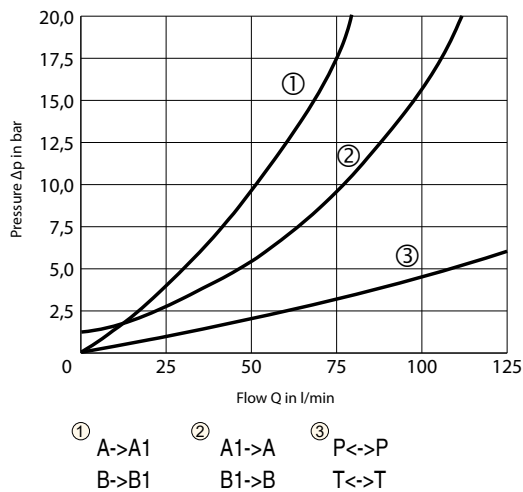

### 5 HYDRAULIC FLUIDS

Seals and materials used on standard valves AM5-\* are fully compatible with hydraulic fluids of mineral oil base, upgraded with antifoaming and antioxidantizing agents. The hydraulic fluid must be kept clean and filtered to ISO 4406 class 19/17/14, or better, and used in a recommended viscosity range from 10 cSt to 60 cSt.

### 6 INSTALLATION DIMENSIONS

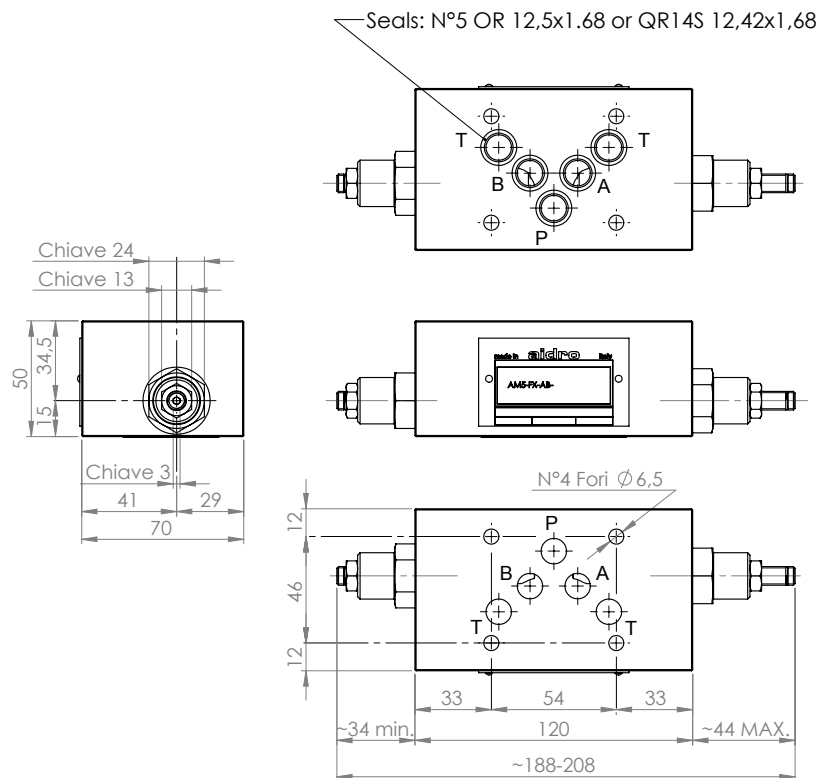

All stackable valves AM5-FX-\* conform with ISO and CETOP specifications for mounting surface dimensions. Valves height 50 mm. Leakage between valve and mounting surface is prevented by the positive compression on their seats of 4 seals of OR type or Quading type.

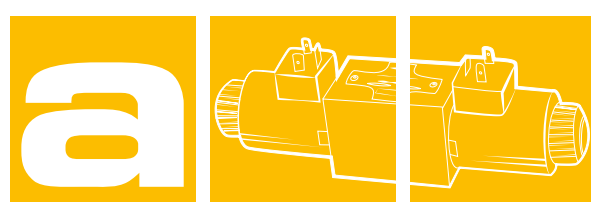

## STACKABLE CHECK VALVES

### AM5-CO-\*

100 l/min 32 MPa (320 bar)

#### 1 DESCRIPTION

Direct operated check valve. All the internal part are made with high strenght steel and are machined with accuracy in order to assure the requested tightness.

The controlled lines are A, B or AB.

The standard surafce treatment of the body is phosphate coated.



#### 2 ORDERING CODE

(1)	(2)	(3)	(4)	(5)	(6)
AM5	-	CO	-	-	/ 10

(1) AM5 : stackable valve CETOP 05 – Pressure 32 MPa (320 bar)

(2) CO : check valve, spring operated

(3) Service lines where the controls operates

AB : controls on A and B. Fluid flows unrestricted A->A1 and B->B1;  
flow is controlled from A1->A and B1->B.

A : flow is controlled from A1->A; free on B.

B : flow is controlled from B1->B; free on A.

(4) Check valve opening (cracking pressure):

no designation : 0.2 MPa (2bar)

4 : 0.4 MPa (4 bar)

(5) Code reserved for special variants

(6) Design number (progressive) of the valve

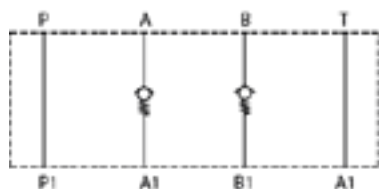
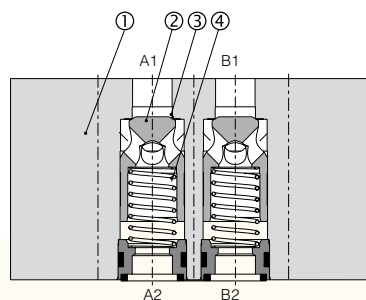
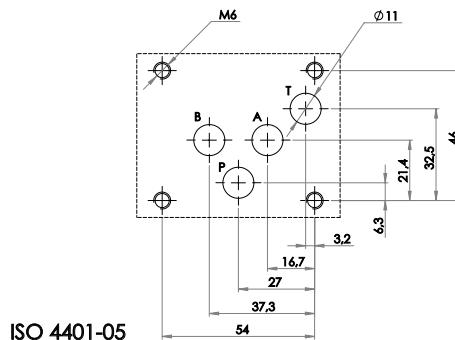

AM5-CO-AB

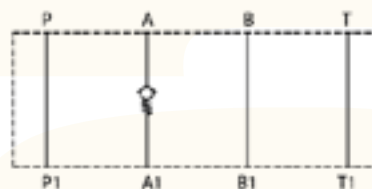

AM5-CO-A

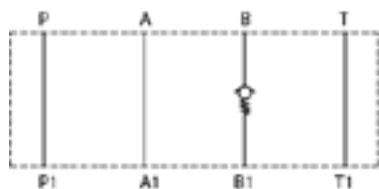

AM5-CO-B



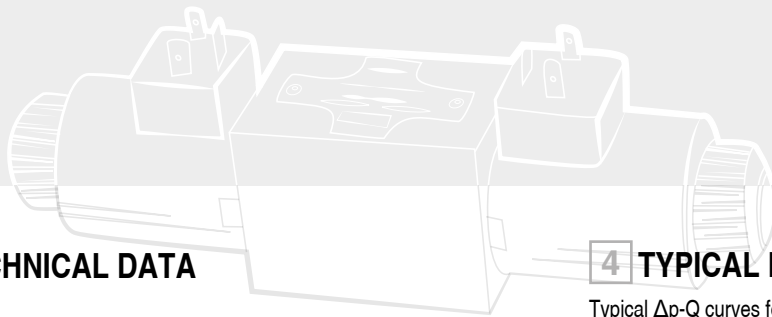

### 3 TECHNICAL DATA

Maximum rec. flow rate on controlled lines	60 l/min
Maximum rec. flow rate on free channels	100 l/min
Maximum nominal pressure	32 MPa (320 bar)
Pressure drops	see 4
Installation and dimensions	see 5

### 4 TYPICAL DIAGRAMS

Typical  $\Delta p$ -Q curves for valves AM5-CO\* in standard configuration, with mineral oil at 36 cSt and T=50°C.

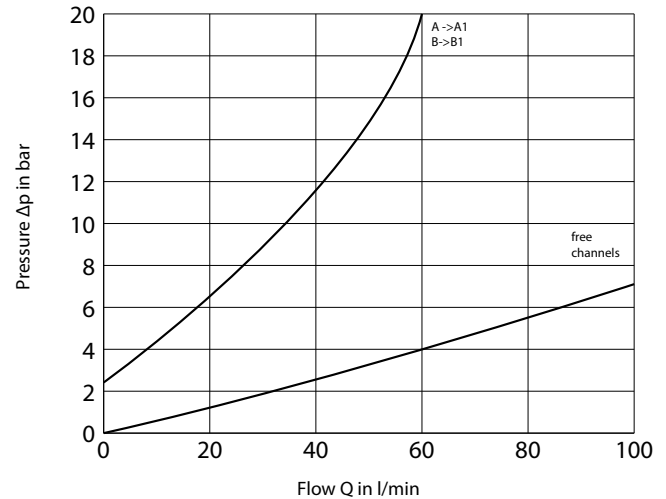

### 5 INSTALLATION DIMENSIONS

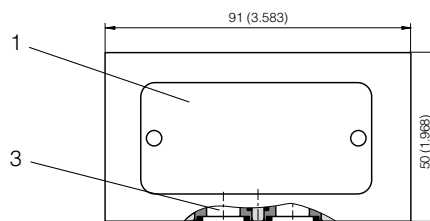
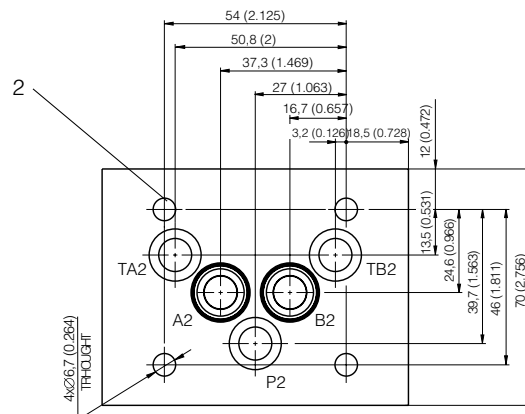

- Dimensions in millimeters:
- 1 Name plate
  - 2 4 mounting through-holes
  - 3 Square ring 12.42x1.68 (5 pcs.) supplied with valve

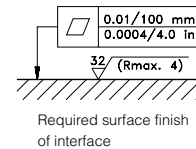

All stackable valves AM5-\* conform with ISO and CETOP specifications for mounting surface dimensions and for valves height (50 mm). Leakage between valve and mounting surface is prevented by the positive compression on their seats of 5 seals of Quad-Rings type 12,42 x 1,68 x 1,68 mm or 5 ORings type 12,5 x 1,68.

## STACKABLE CHECK VALVES

### AM5-CP-\*

100 l/min 32 MPa (320 bar)

#### 1 DESCRIPTION

Pilot operated check valve. All the internal part are made with high strenght steel and are machined with accuracy in order to assure the requested tightness. The controlled lines are A, B or AB. The standard surface treatment of the body is phosphate coated. Plugs are zinc coated.

#### 2 ORDERING CODE

(1)	(2)	(3)	(4)	(5)	(6)
AM5	-	CP	-	-	/ 10

- (1) AM5 : stackable valve CETOP 05 - Pressure 32 MPa (320 bar)
- (2) CP : check valve, pilot operated (hydraulically)
- (3) Service lines where the controls operates:  
 AB: p.o. checks on A and B. Fluid flows A->A1 and B->B1 and flow A1 ->A (or B1->B) is permitted only when B (or A) is pressurized  
 A: p.o. check on A; flow A1->A is permitted only when B is pressurized  
 B: p.o. check on B; flow B1->B is permitted only when A is pressurized
- (4) Check valve opening (cracking) pressure (Pm) for free flow A->A1 and B->B1 no designation (standard): Pm approx 0.2 MPa (2 bar)
- (5) Code reserved for special variants (materials, seals, surface treatments, etc.)
- (6) Design number (progressive) of the valves.

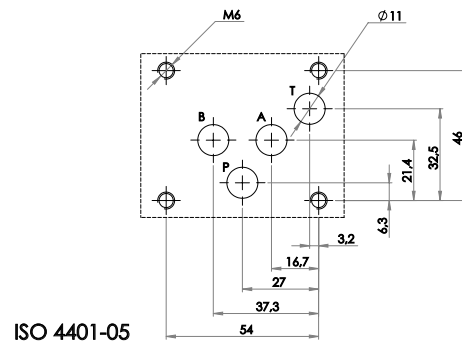
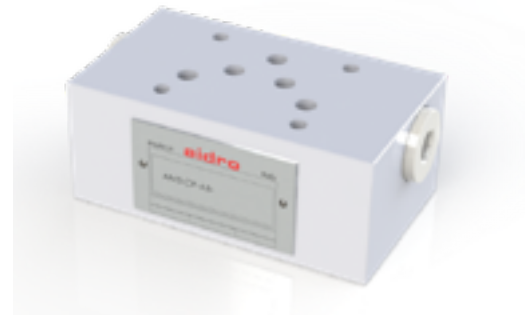

AM5-CP-AB

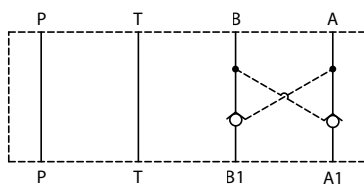

AM5-CP-A

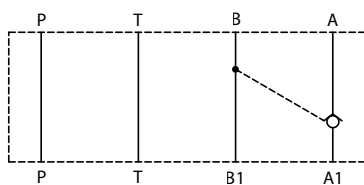

AM5-CP-B

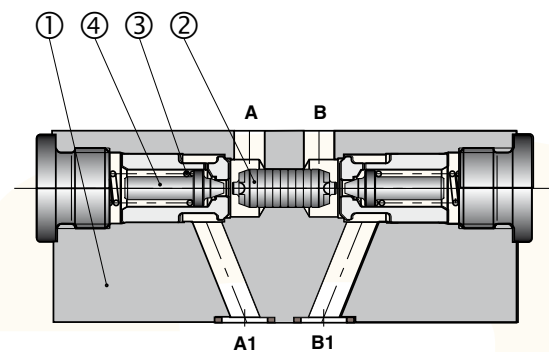
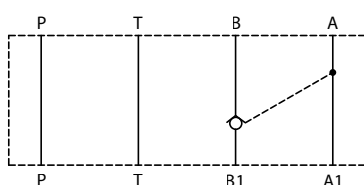

Fluid flows freely on P and T lines; on service lines A and/or B with p.o. check, fluid flows from A -> A1 (and/or B -> B1) overcoming the force of spring acting on poppet 4, and fluid is blocked from A1-> A (and/or B1-> B). When, by switching the solenoid operated 4-way directional valve, pressure is made available at, for instance, port B fluid flows B -> B1 and the pilot piston 2, shifting from its central position, forces poppet 4, on service line A, to open and permit flow A1 -> A. The valve housing 1 is phosphatate coated.

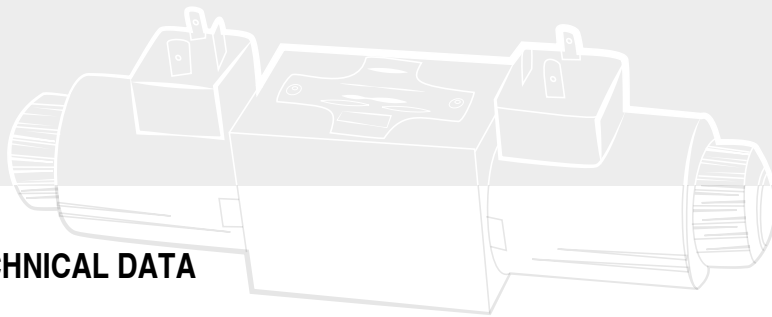

### 3 TECHNICAL DATA

Maximum rec. flow rate	100 l/min	Piloting pressure:
Maximum nominal pressure	32 MPa (320 bar)	To shift the pilot piston and to open the check in A the piloting pressure must be, at B:
Pressure drops	see 4	$P_p = P_b = \frac{P_{a1} + P_m - P_a}{5,6} + P_a$
Pilot area ratio piston/poppet	approx 5,6	where: $P_p$ = piloting pressure; $P_b$ = pressure in B;
Installation and dimensions	see 5	$P_a$ = pressure in A; $P_{a1}$ = pressure in A1;
Mass	approx 3 kg	$P_m$ = check valve opening pressure (spring)
		or to open the check in B:
		$P_p = P_a = \frac{P_{b1} + P_m - P_b}{5,6} + P_b$

### 4 TYPICAL DIAGRAMS

Typical  $\Delta p$ -Q curves for valves AM5-CP-AB in standard configuration, with mineral oil at 36 cSt and at 50°C.

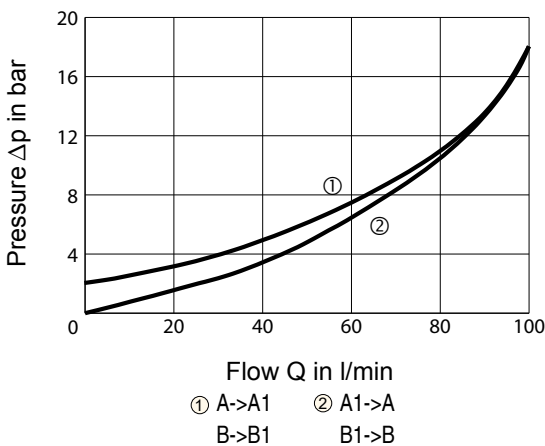

### 5 INSTALLATION DIMENSIONS

Seals:  
5 x OR 12,5 x 1,68  
or  
5 x QR14S 12,42 x 1,68

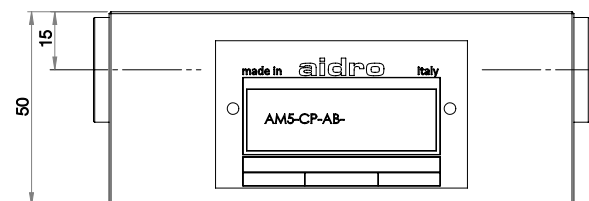
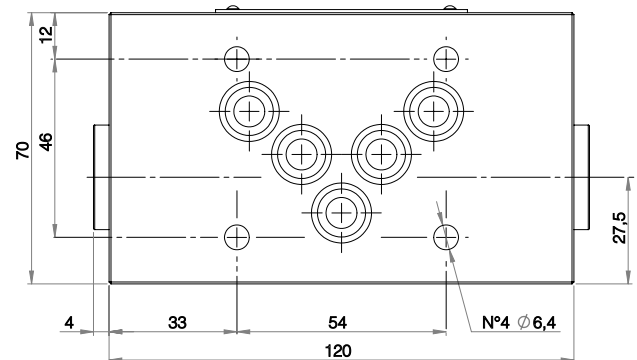

### 6 HYDRAULIC FLUIDS

Seals and materials used on standard valves AM5-\* are fully compatible with hydraulic fluids of mineral oil base, upgraded with antifoaming and antioxidizing agents. The hydraulic fluid must be kept clean and filtered to ISO 4406 class 19/17/14, or better, and used in a recommended viscosity range from 10 cSt to 60 cSt.

All stackable valves AM5-CP-\* conform with ISO and CETOP specifications for mounting surface dimensions and for valves height (50mm). Leakage between valve and mounting surface is prevented by the positive compression on their seats of seals (of OR type or Quading type).

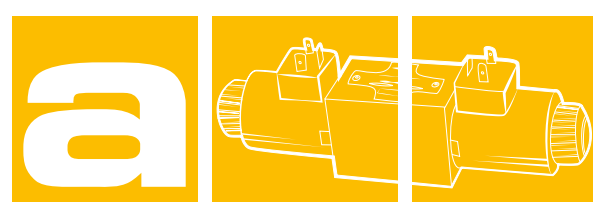

## STACKABLE VALVES PILOT OPERATED

### AM5-MP-\*

100 l/min 32 MPa (320 bar)

#### 1 DESCRIPTION

Stackable pressure relief valve pilot operated. The valve is made with a steel body combined with a pressure relief cartridge valve pilot operated for a stable pressure control.

The body of the valve is phosphate coated. The cartridge valve is zinc coated. The pressure can be set in different pressure ranges.

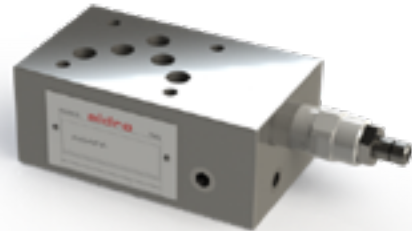

#### 2 ORDERING CODE

(1)	(2)	(3)	(4)	(5)	(6)	(7)
AM5	-	MP	-	/	-	/ 10

(1) AM5: stackable valve CETOP 05 - Pressure 32 MPa (320 bar)

(2) MP: pressure relief-pilot operated (hydraulically)

(3) Service lines where the controls operates:

P : relief on P and discharge to T

A : relief on A and discharge to T

BA: independent relief on B and on A and discharge to T

AB: relief on A and B with crossed discharge

(4) Pressure adjustment ranges:

6,3 from 10 to 70 bar

12,5 from 10 to 140 bar

20 from 20 to 210 bar

32 from 20 to 320 bar

(5) pressure adjustment range for relief on A (only for models AM5-MP-BA or for relief on B for models AM5-MP-AB)

(6) code reserved for special variants (materials, seals, surface treatments, etc.)

(7) Design number (progressive) of the valves

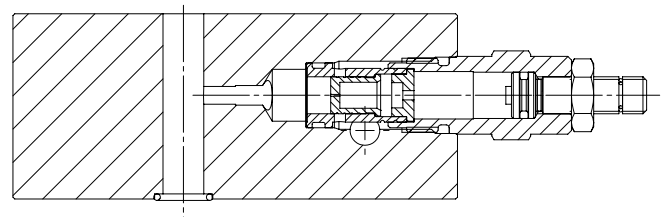
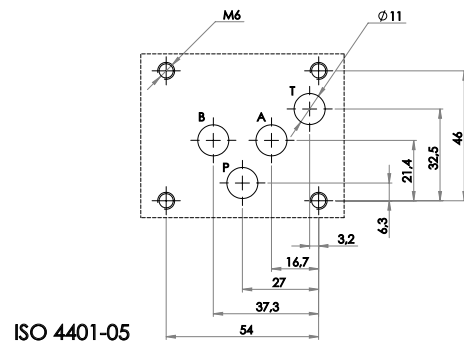

AM5-MP-P

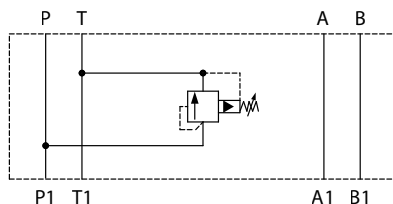

AM5-MP-AB

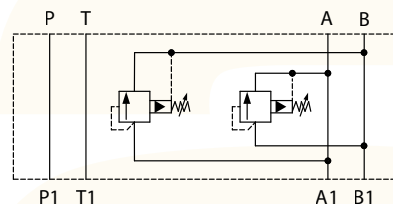

AM5-MP-A

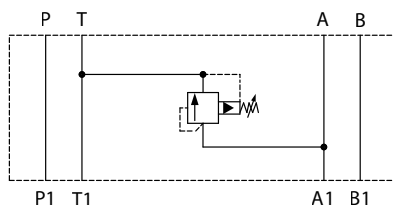

AM5-MP-BA

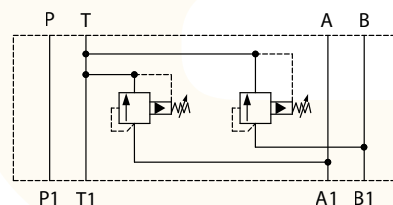

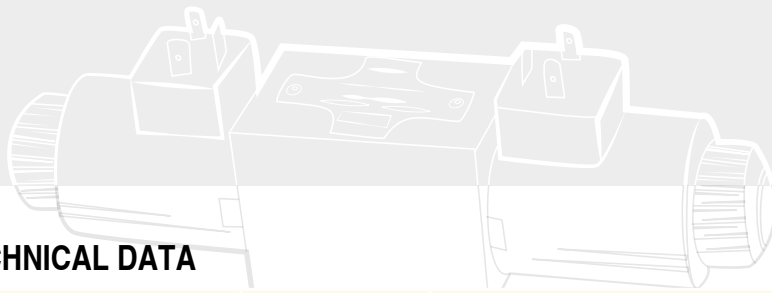

### 3 TECHNICAL DATA

Maximum rec. flow rate	100 l/min	Adjustment of the relief pressure:
Maximum nominal pressure	32 MPa (320 bar)	Relief pressure is reached when the axial hydraulic forces on piston equal the force of spring; the value of the relief pressure can be therefore changed, within the limits of the chosen adjustment range, by changing the compression of spring. To increase the relief pressure, turn clock wise the adjustment screw ch.5 , after having unlocked its nut ch.17.
Pressure relief curves	see 4	The pressure gradient is approx:
Installation and dimensions	see 5	6,3 : 20 bar/turn
mass:		12,5 : 40 bar/turn
AM5-MP-P	approx 2,7 Kg	20 : 63 bar/turn
AM5-MP-AB	approx 3,6 Kg	32 : 100 bar/turn
		When the required level of pressure is reached, lock the nut.

### 4 TYPICAL DIAGRAMS

Typical  $\Delta p$ -Q curves for valves AM5-CP-AB in standard configuration, with mineral oil at 36 cSt and at 50°C.

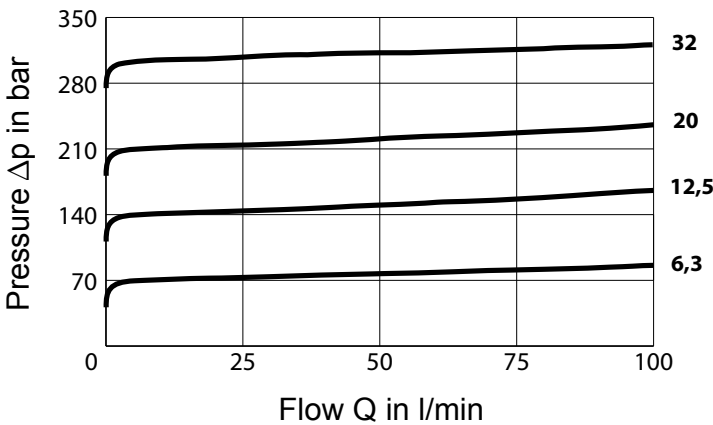

### 5 HYDRAULIC FLUIDS

Seals and materials used on standard valves AM5-\* are fully compatible with hydraulic fluids of mineral oil base, upgraded with antifoaming and antioxidantizing agents. The hydraulic fluid must be kept clean and filtered to ISO 4406 class 19/17/14, or better, and used in a recommended viscosity range from 10 cSt to 60 cSt

All stackable valves AM5-MP-\* conform with ISO and CETOP specifications for mounting surface dimensions (see also front page) and for valves height (50mm). Leakage between valve and mounting surface is prevented by the positive compression on their seats of 5 seals (OR 2050).

### 6 INSTALLATION DIMENSIONS

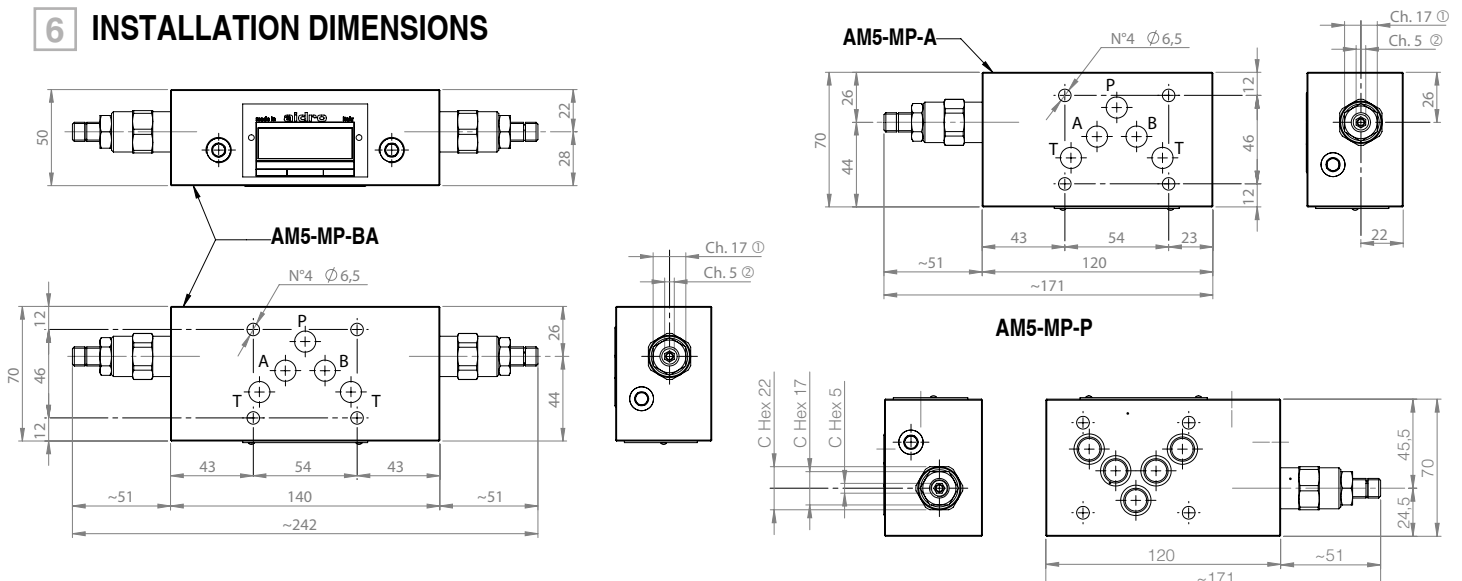

## STACKABLE VALVES PRESSURE REDUCING

### AM5-RP-\*

100 l/min 32 MPa (320 bar)

#### 1 DESCRIPTION

Stackable pressure reducing valve pilot operated. The valve is made with a steel body combined with a pressure relief valve. The body of the valve is phosphate coated. The cartridge valve is zinc coated. The pressure can be set in different pressure ranges.



#### 2 ORDERING CODE

(1)	(2)	(3)	(4)	(5)	(6)
AM5	-	RP	-	-	/ 20

(1) AM5 : stackable valve CETOP 05 - Pressure 32 MPa (320 bar)

(2) RP : pressure reducing, pilot operated

(3) Lines where the control operates

P : relief on P and discharge to T

A : relief on A and discharge to T

B : relief on A and discharge to T

(4) controlled pressure adjustment ranges :

6,3: from 0,5 to 7 MPa (from 5 to 70 bar)

16: from 1 to 16 MPa (from 10 to 160 bar)

20: from 1,6 to 2,1 MPa (from 16 to 210 bar)

(5) Code reserved for special variants

V: adjustment with knob

(6) Design number (progressive) of the valves

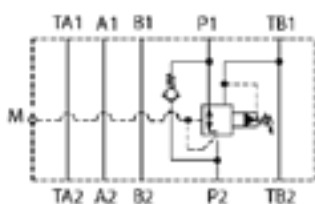
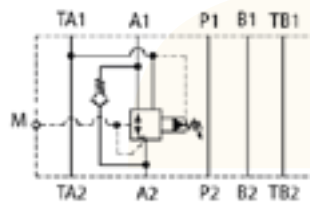
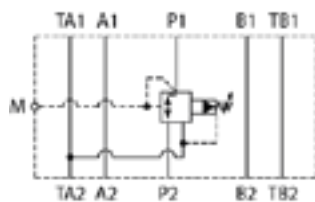
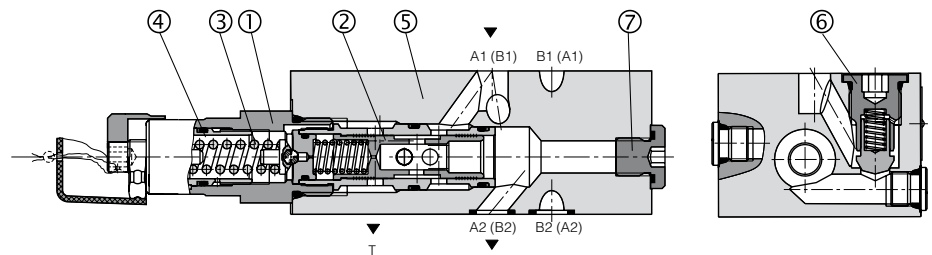
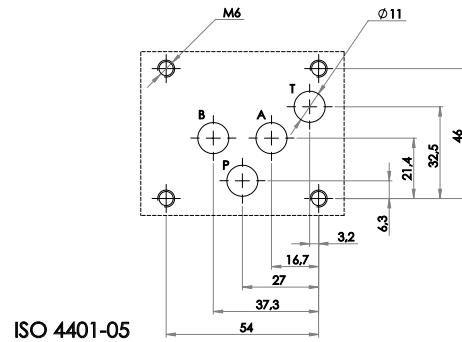

All valves type AM5-RP-\* reduce pressure P of the solenoid valve as follows : On version P, the valve constantly reduce pressure at the settled value On version A, the pressure is reduced in direction A -> A1 while the return is free On version B, the pressure is reduced in direction B -> B1 while the return is free All valves type AM5-RP-\* have a 1/4" BSP manometer port (M) for the direct reading of the reduced pressure.

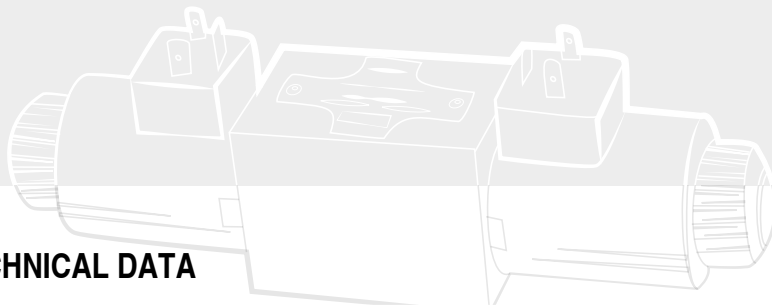

### 3 TECHNICAL DATA

Maximum rec. flow rate on regulated line	80 l/min	Adjustment of the pressure: Reduced pressure is obtained by throttling the flow on spool which is balanced, on one side, by the reduced pressure and, on the other side, by the positioning spring and by the pilot pressure. Pilot pressure is established by the action of spring on the pilot valve. The value of the reduced pressure is changed by changing the compression of spring. To increase the value of the reduced pressure, turn clockwise acting on adjustment element 2 (C hex 6 mm), after having unlocked its retaining nut (C hex 27 mm).
Maximum input pressure	32 MPa (320 bar)	
Maximum rec. flow rate on free lines	100 l/min	Pilot pressure is established by the action of spring on the pilot valve. The value of the reduced pressure is changed by changing the compression of spring. To increase the value of the reduced pressure, turn clockwise acting on adjustment element 2 (C hex 6 mm), after having unlocked its retaining nut (C hex 27 mm).
Pilot flow rate	0,7 l/min	
mass		
3,2 kg	Model A,B	
2,85 kg	Model P	

### 4 INSTALLATION DIMENSIONS (mm)

AM5-RP-A/\*

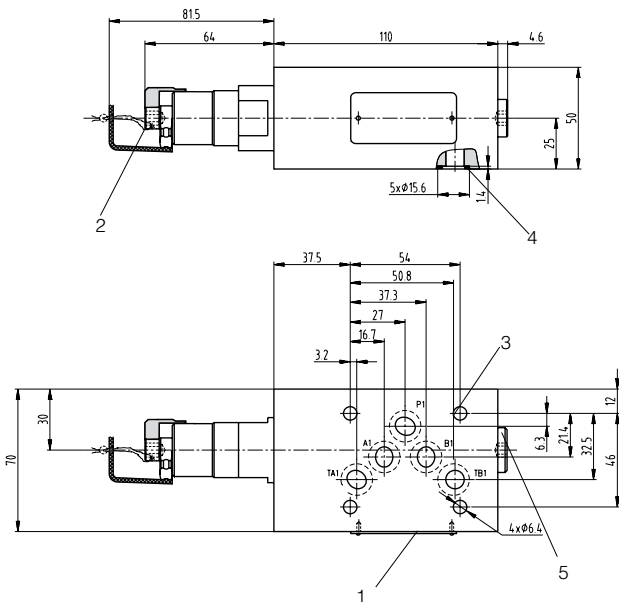

AM5-RP-B/\*

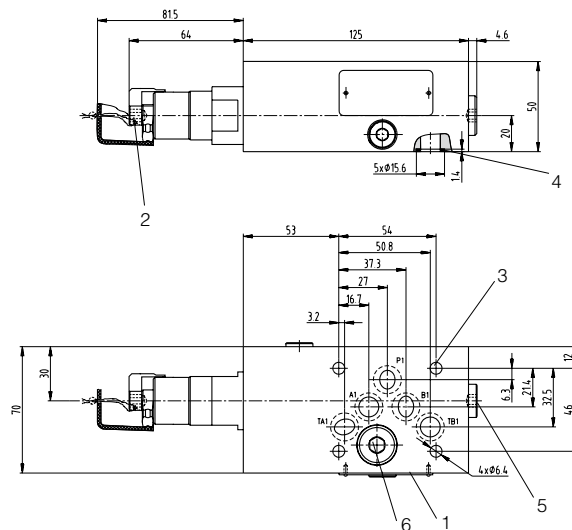

### 5 HYDRAULIC FLUIDS

Seals and materials used on standard valves AM5-\* are fully compatible with hydraulic fluids of mineral oil base, upgraded with antifoaming and antioxidantizing agents. The hydraulic fluid must be kept clean and filtered to ISO 4406 class 19/17/14, or better, and used in a recommended viscosity range from 10 cSt to 60 cSt.

### 6 TYPICAL DIAGRAMS

measured at  $v=36$  cSt and  $50^{\circ}\text{C}$

AM5-RP-P/\*

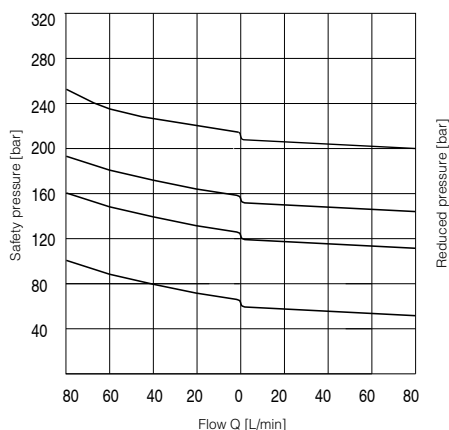
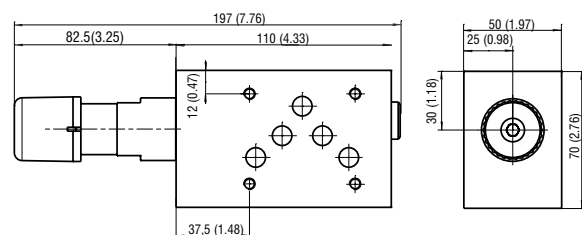

All stackable valves AM5-RP-\* conform with ISO and CETOP specifications for mounting surface dimensions and for valves height (50 mm). Leakage between valve and mounting surface is prevented by the positive compression on their seats of 5 seals type Quad-Ring (12.42 x 1.69 mm)

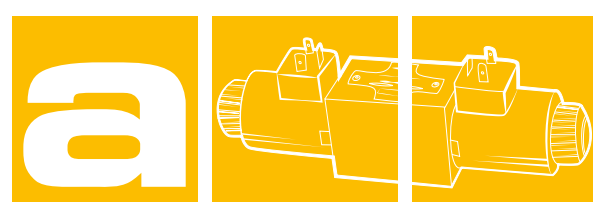

## MONOBLOCK WITH MULTIPLE SECTIONS ISO 05

### MR-5-\*G

120 l/min (300 bar)

#### 1 DESCRIPTION

- Ports A and B (1/2" BSP) on the sides
- P and T lines with ports (3/4" and 1" BSP) on the two rear sides
- Parallel connections P and T

Monoblocks with multiple sections from 1 to 8, for hydraulic 4 ways operated valves ISO 05 with parallel internal connections P and T. The utility ports A and B are positioned, in pairs, laterally to the valve assembly face.

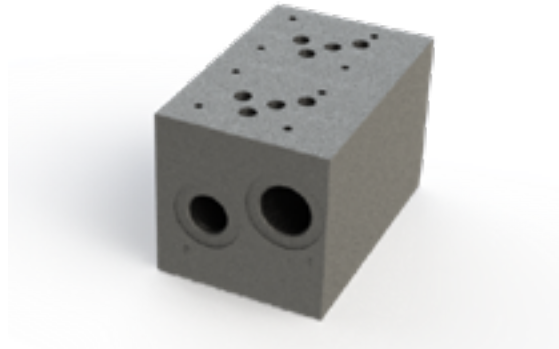

#### 2 ORDERING CODE

(1)	(2)	(3)	(4)
MR	-	5	G

Type	Number of stations 03	Q max recommended (*) l/min
MR-5-1 G	1	120 - 120
MR-5-2 G	2	120 - 120
MR-5-3 G	3	100 - 120
MR-5-4 G	4	100 - 120
MR-5-5 G	5	100 - 120
MR-5-6 G	6	100 - 120
MR-5-7 G	7	80 - 120
MR-5-8 G	8	80 - 120

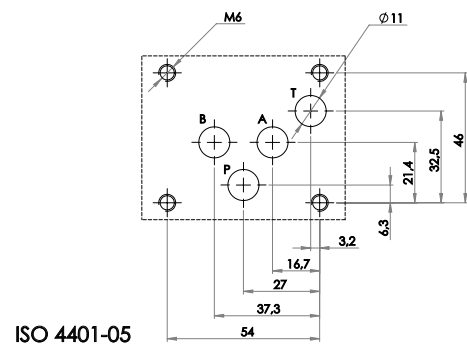

Type	X (mm)	Z (mm)	mass (kg)
MR-5-1 G	80	56	5,37
MR-5-2 G	160	136	11,30
MR-5-3 G	240	216	17,00
MR-5-4 G	320	296	22,70
MR-5-5 G	400	376	28,5
MR-5-6 G	480	456	34,00
MR-5-7 G	560	536	39,90
MR-5-8 G	640	616	45,60



### 3 TECHNICAL DATA

Material	Cast Iron GG 25
Coating:	Manganese phosphating
Pressure allowed in the ports	P, A, B and T = 300 bar
Incoming flow, maximum recommended	From 80 to 120 l/min, decreasing with the rise of the number of sections.
Connecting ports	Standard female cylindrical BSP thread with maximum rugosity of a surface Ra 1,6 for the fitting of connections. A and B 1/2" BSP - one pair per section. P 3/4" BSP and T 1" BSP - one pair on each rear side of a monoblock; it allows, if necessary, to double supply (P) or double outlet (T); close the unused ports. (* ) If both pairs of ports P and T are used, maximum recommended Q values can be increased.
Installation:	4 mounting holes threaded M 12 on the rear side
Mounting surface of the valve	
Planarity of the surface	0,01/100
Rugosity:	Ra 0,8

### 4 INSTALLATION DIMENSION

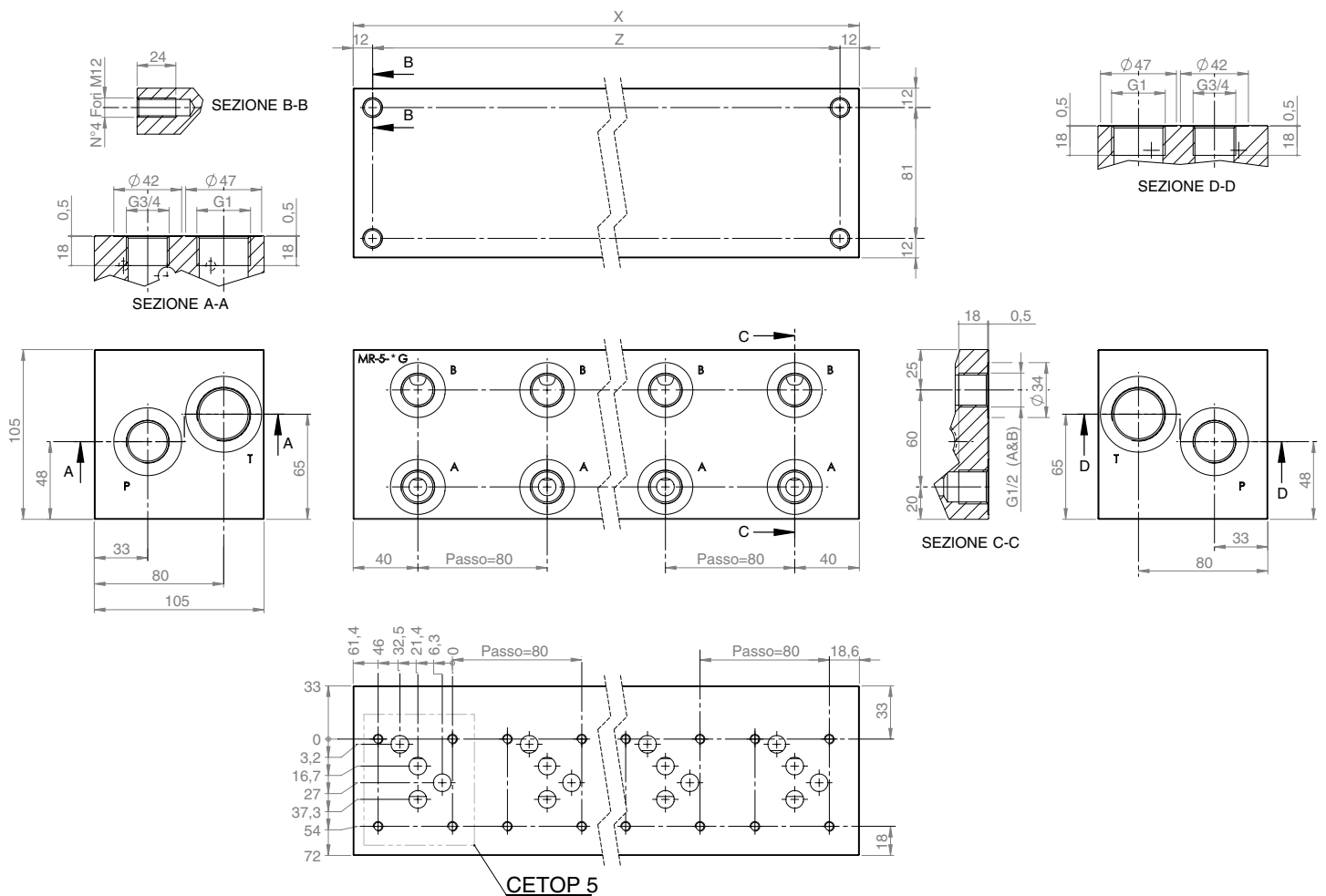

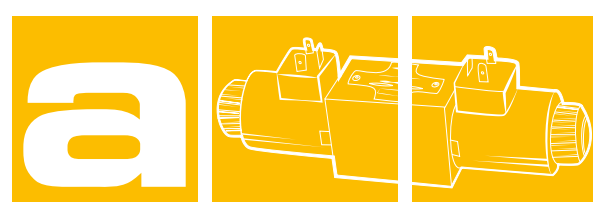

## MONOBLOCK WITH MULTIPLE SECTIONS ISO 05

### MRK-5-\*G

120 l/min (300 bar)

#### 1 DESCRIPTION

- Ports A and B (1/2" BSP) on the back
- P (3/4" BSP) and T (1" BSP) lines with ports on the two rear sides
- Parallel connections P and T

Monoblocks with multiple sections from 2 to 8, for hydraulic 4 ways operated valves ISO 05 with parallel internal connections P and T. Ports A and B are positioned, in pairs, on the back side of the block with respect to the valve assembly face.



#### 2 ORDERING CODE

(1)	(2)	(3)	(4)
MRK	-	5	-
			G

Type	Number of stations 03	Q max recommended (*) l/min
MRK-5-2 G	2	120
MRK-5-3 G	3	100
MRK-5-4 G	4	100
MRK-5-5 G	5	100
MRK-5-6 G	6	100
MRK-5-7 G	7	80
MRK-5-8 G	8	80

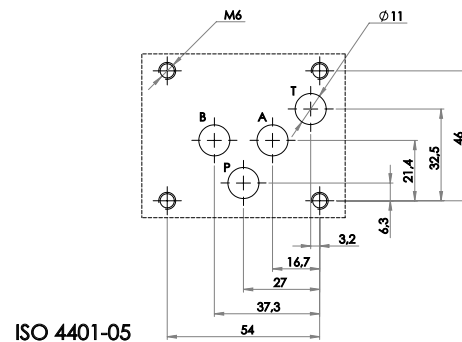

Type	X (mm)	Z (mm)	mass (kg)
MR-5-2 G	160	136	11,30
MR-5-3 G	240	216	17,00
MR-5-4 G	320	296	22,70
MR-5-5 G	400	376	28,5
MR-5-6 G	480	456	34,00
MR-5-7 G	560	536	39,90
MR-5-8 G	640	616	45,60

### 3 TECHNICAL DATA

Material	Cast Iron GG 25
Coating:	Manganese phosphating
Pressure allowed in the ports	P, A, B and T = 300 bar
Incoming flow, maximum recommended	From 80 to 120 l/min, decreasing with the rise of the number of sections.
Connecting ports	Standard female cylindrical BSP threads with maximum rugosity of a surface Ra 1,6 for the fitting of connections. A and B ports 1/2" BSP - one pair per section. P 3/4" BSP and T 1" BSP - one pair on each rear side of a monoblock; it allows, if needed, to double supply (P) or double outlet (T); close the unused ports. (* If both pairs of ports P and T are used, maximum recommended Q values can be increased.
Installation:	4 mounting holes threaded M 12 on the rear side
Mounting surface of the valve	
Planarity of the surface	0,01/100
Rugosity:	Ra 0,8
Auxiliary ports:	On the side of monoblock there are auxiliary ports threaded 1/4" BSP, connected to the line A (one per each section). Monoblocks are sold with these ports closed by plugs with cylindric thread, with hexagon socket for 6 mm key.

### 4 INSTALLATION DIMENSION

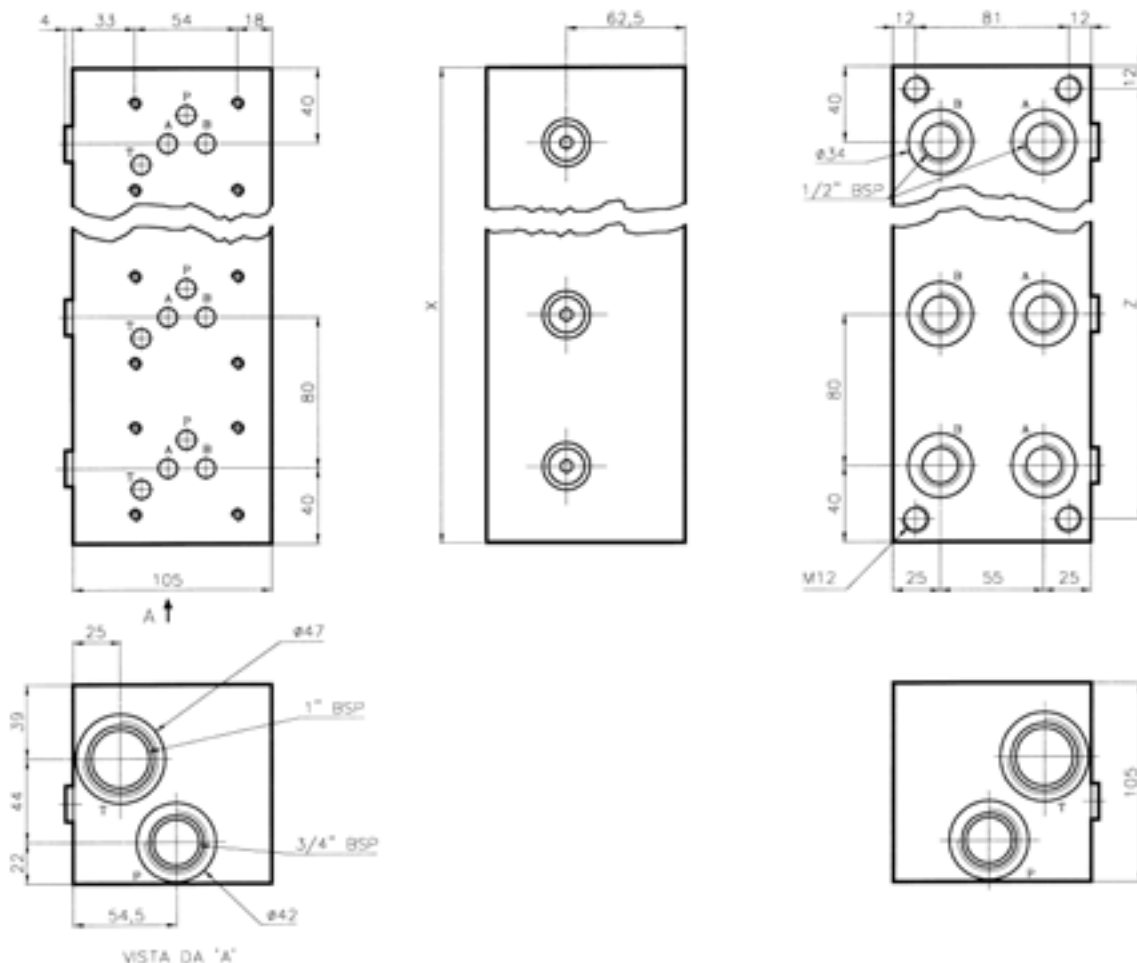



# SUMMARY



## **5** CETOP 07-08

4/2 and 4/3 DIRECTIONAL CONTROL VALVES PILOT OPERATED

**HD7-\*** 0001

---

4/2 and 4/3 WAY DIRECTIONAL CONTROL VALVES PILOT OPERATED

**HD8-\*** 0006

---

PRESSURE RELIEF VALVE WITH UNLOADING AND PRESSURE SELECTION

**GMG\*-\*/40** 0011

---

PRESSURE RELIEF VALVE WITH UNLOADING AND PRESSURE SELECTION

**GMG\*-\*/60** 0014

---

**aidro**  
hydraulics



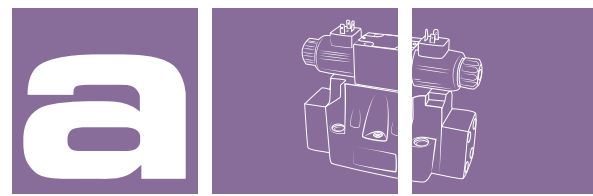

## 4/2 and 4/3 DIRECTIONAL CONTROL VALVES PILOT OPERATED

### HD7-\*

350 l/min 32 MPa (320 bar)

#### 1 DESCRIPTION

Valves HD7-ES are directional control valve pilot operated with subplate mounting interface acc. to ISO 4401-07, DIN 24340 (CETOP 07 - NG16). The body is made with a high quality casting. The CETOP 3 pilot valve is available with interchangeable metallic DC solenoids, also for AC power supply using a built-in rectifier bridge inside the coil. In the standard version the valve housing is phosphated.



#### 2 ORDERING CODE

(1)	(2)	(3)	(4)	(5)	(6)	(7)
HD7	-	-	/		-	/ 40

(1) HD7: 4-way directional control valve CETOP 07 - Pressure 32 MPa (320 bar)

(2) Variants:

- ES: electrically controlled, standard
- HH: hydraulically piloted (main body)

(3) Spool type:

- number is the main spool type
- letter is the solenoid or spring arrangement:
  - C : 2 solenoids spool is spring centered (3 position)
  - N : 2 solenoids pilot is detented (2 position)
  - LL : 1 solenoid (a), spool is spring/hydr. offset (2 position, end to end)
  - ML : 1 solenoid (a), spool is spring offset (2 position, middle to end)
  - LM : 1 solenoid (a), spool is spring offset (2 position, end to middle)
- b : only for versions LL, MI, LM, see also functional symbols

(4) Code reserved for options and variants

- C : adjustable limits for main spool stroke
- D : double flow control valve to adjust shifting speed
- G : adjustable limits and adjustable shifting speed
- P : check valve incorporated in P port of the valve

(5) Pilot and drain arrangement

- No designation : internal pilot and external drain (standard)
- I : internal pilot and internal drain
- E : external pilot and external drain

(6) Electric voltage and solenoid coils

- 0000 : no coils
- 012C : coils for V12DC
- 024C : coils for V24DC
- 115A : coils for V110/50 - V115/60 AC
- 230A : coils for V220/50 - V230/60 AC
- See also electric characteristic

(7) Design number (progressive) of the valves

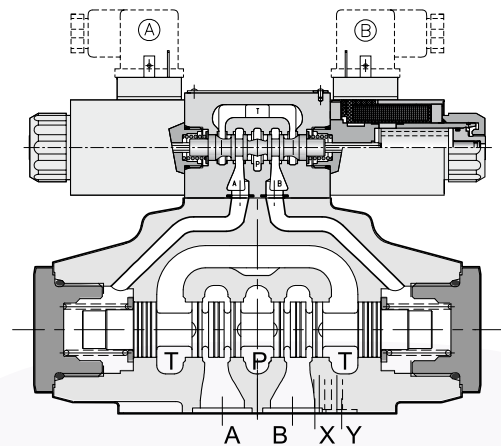
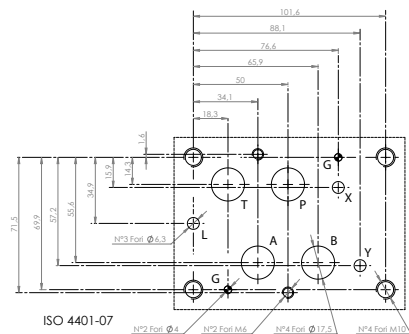

The HD7-ES solenoid operated - hydro-piloted valves are consisting of an HD3-ES type solenoid operated directional control valve (see data sheet HD3-ES) that operates a 4-way hydro-piloted control valve with a connection surface in accordance with the CETOP standards. They are available in various configurations and spool types. The pilot and the drain connections can be made internal or external by inserting or removing the accordant threaded plugs located in the main directional control valve. A wide range of configurations and different solenoid operated-hydro-piloted directional control valve spool positions are available: - 4-way, 3-position directional control valve, with two solenoids; positioning of the spool in center position is obtained with centering springs. - 4-way, 2-position directional control valve with one solenoid; positioning of the spool in center position is determined hydraulically by the pilot valve and mechanically (even without pressure) by the main stage return spring. - 4-way, 2-position directional valve, with two solenoids, with mechanical detent of the shifted pilot spool positions when solenoids are de-energized. The basic surface treatment of the valve housing is phosphate coated and the solenoids are zinc coated.

### 3 TECHNICAL DATA

Max. recommended flow (spring centering)	250 l/min
Max. recommended flow (hydraulic centering and hydraulic off set)	350 l/min
Max pressure at P, A, B ports	320 bar
Max pressure at T port (internal drain)	160 bar
Max pressure at T port (external drain)	250 bar
Pilot pressure minimum	5 bar
Pilot pressure Max. recommended	200 bar
Mass:	
HD7-ES	approx. 9 Kg
HD7-HH	approx. 7,5 Kg

### 4 SPOOL IDENTIFICATION AND INTERMEDIATE POSITION TRANSITORIES

1C			77C		
0C			56C		
3C			8C		
4C			76C		
Two positions with return spring			Two positions with mechanical detent on pilot valve		
1LL			1N		
0LL			0N		
1ML					
1LLb					
0LLb					
1MLb					

## 5 TYPICAL DIAGRAMS

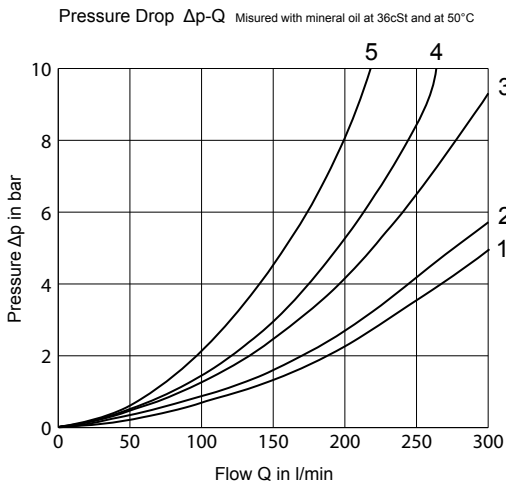

Spool type	spool position	Connections				
		P-A	P-B	A-T	B-T	P-T
Curves on graph						
1C	Energized	1	1	2	3	
0C	De-energized	5	5	1	2	6*
3C	De-energized			4	4	
	Energized	1	1	1	2	
4C	De-energized			3	4	6
	Energized	6	6			
67C	De-energized	1	4	2	3	
	Energized		5			
77C	De-energized			2	4	6°
	Energized	1	1		2	
55C	De-energized			3	4	6
	Energized	6	6			
56C	De-energized			4	3	
	Energized	6	6			
35C	Energized	1	1	2	3	
8C	De-energized	4°	4	2	3	
	Energized	5	5			
76C	De-energized			3	3	
	Energized	1	1	1		
65C	De-energized	4		2	3	
	Energized	5	1			
1LL,OLL,1ML	De-energized	1		2	3	
	Energized		1			
1N,ON	Energized	1	1	2	3	

## 6 INSTALLATION DIMENSION

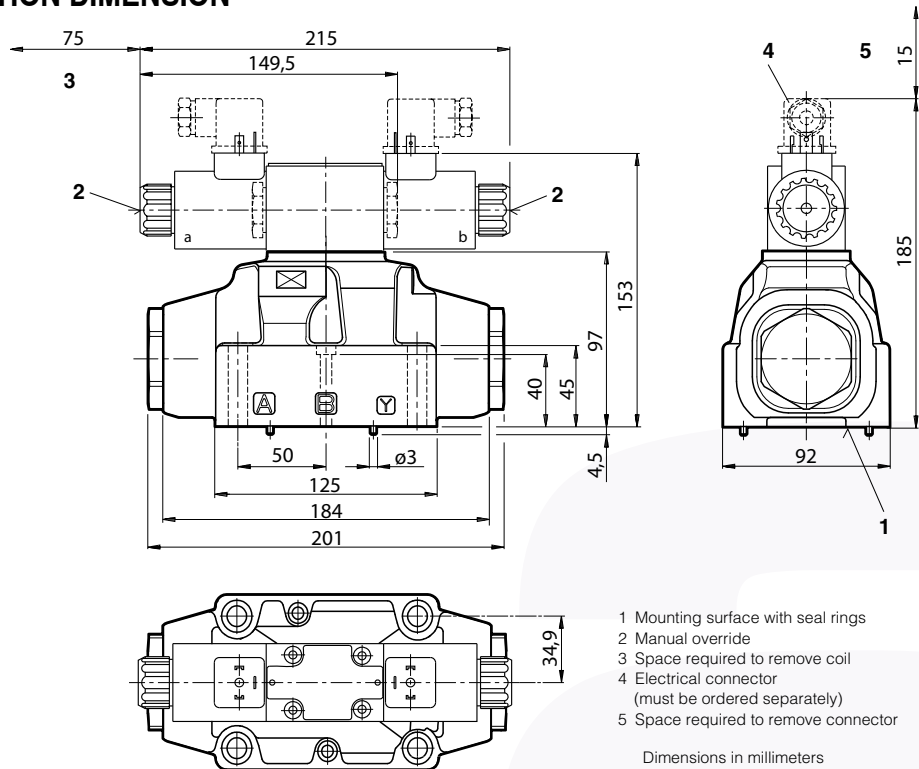

Single valve fastening:	4 bolts M10 x 60 * 2 bolts M6 x 60 *	* Bolts is not supplied
Bolt torque:	M10 x 60: 40 Nm - bolts A 8.8 M6 x 60: 8 Nm - bolts A 8.8	
Threads of mounting holes:	M6 x 18; M10 x 18	
Seal rings:	4 O-rings type 22.22 x 2.62 (OR 130) 2 O-rings type 10.82 x 1.78 (OR 2043)	



## 7 TYPE OF COMMAND

### Solenoid control: HD7-ES

The valve is supplied with a pilot solenoid valve type HD3-ES.

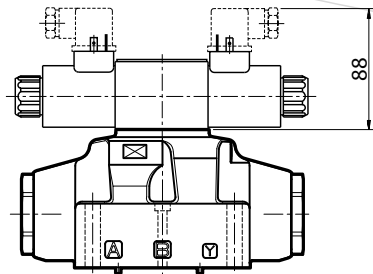

### Hydraulic control: HD7-HH

The valve is supplied as main body.

X and Y connections are used for the hydraulic control of the valve.

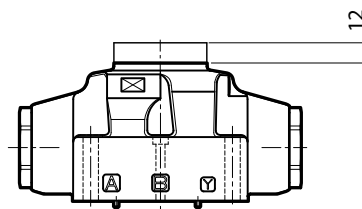

## 8 CONTROLS

### Control of the main spool stroke: C

It is possible to introduce special stroke controls in the heads of the hydro-piloted valve so as to vary the maximum spool stroke. This solution allows control of the flow rate from the pump to the actuator and from the actuator to the outlet, obtaining a double adjustable control on the actuator. Add the letter **C** to the identification code to request this device.

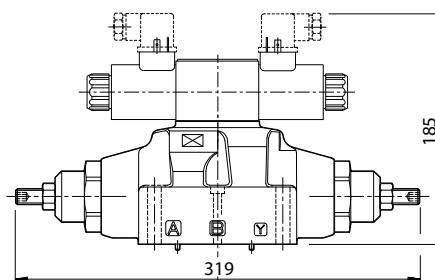

### Control of the main spool shifting speed: D

By placing a double flow control valve between the pilot solenoid valve and the hydro-piloted valve, the piloted flow rate can be controlled and therefore the shifting speed can be varied. Add the letter **D** to the identification code to request this device.

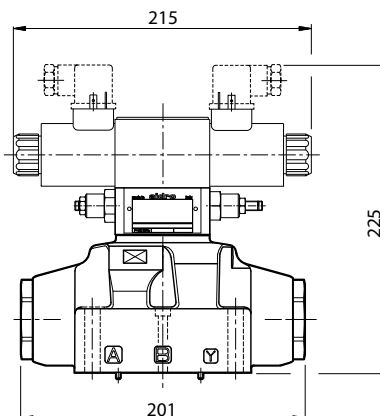

### Control of the main spool stroke and shifting speed: G

It is possible to have the valve fitted with both the spool stroke device and the piloting flow rate control device. Add the letter **G** to the identification code to request this solution.

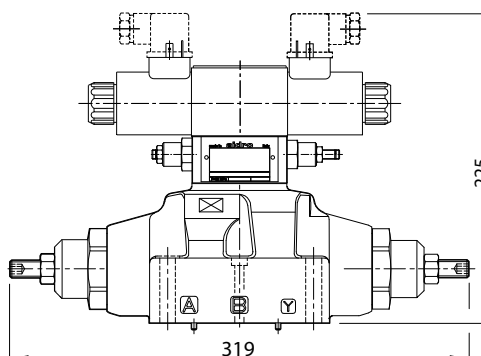

## 9 SPECIAL CONFIGURATION

### Solenoid valves with special spools

Besides the standard configurations (see pages 2 and 3), we can develop, on request, connection diagrams with special spools for a wide range of applications: consult our technical department for their identification, feasibility and operating limits.

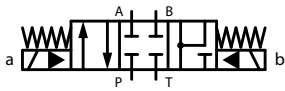

19C

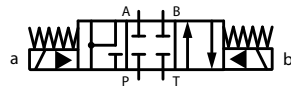

18C

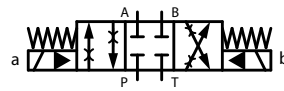

15C

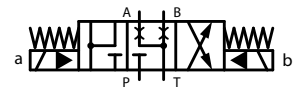

38C

### Check valve incorporated on line P: P

Valve HD7 is available upon request with check valve incorporated on line P. This is particularly useful to obtain the necessary piloting pressure when the main control valve, in the rest position, has line P connected to the T outlet. The cracking pressure is 5 bar. Add P to the identification code for this request.

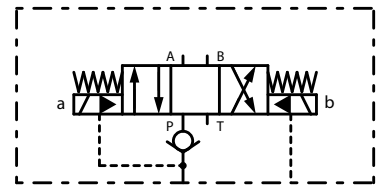

## 10 PILOT and DRAIN

The HD7 valves are available with pilot and drain, both internal and external. The version with external drain allows for a higher back pressure on the outlet.

Type of valve		Plug assembly	
		X	Y
HD7-ES-**/*	Internal pilot and external drain	NO	YES
HD7-ES-**/*I	Internal pilot and internal drain	NO	NO
HD7-ES-**/*E	External pilot and external drain	YES	YES
HD7-ES-**/*EI	External pilot and internal drain	YES	NO

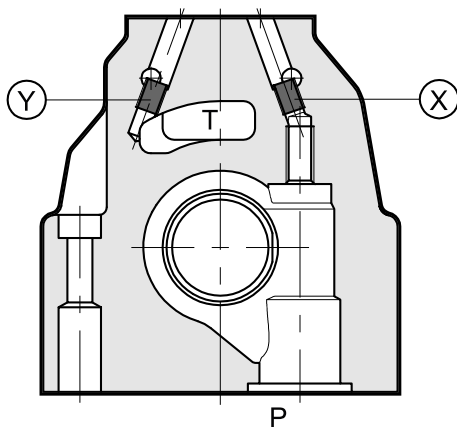

X: plug M6 x 8 for external pilot  
Y: plug M6 x 8 for external drain

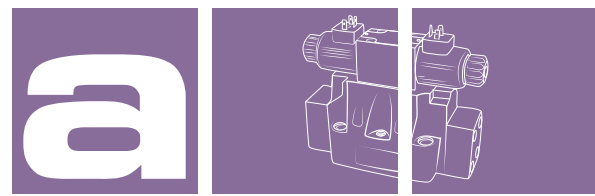

## 4/2 and 4/3 WAY DIRECTIONAL CONTROL VALVES PILOT OPERATED HD8-\*

600 l/min 32 MPa (320 bar)

### 1 DESCRIPTION

Valves HD8-ES are directional control valve pilot operated with subplate mounting interface acc. to ISO 4401-08, DIN 24340 (CETOP 08 - NG25).

The body is made with an high quality casting.

The CETOP 3 pilot valve is available with interchangeable metallic DC solenoids, also for AC power supply using a built-in rectifier bridge inside the coil.

In the standard version the valve housing is phosphated.

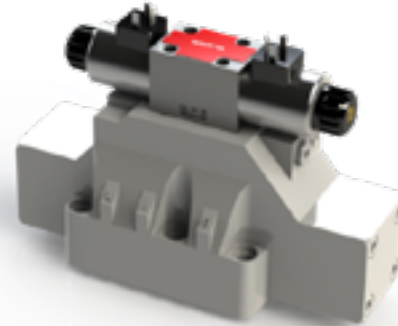

### 2 ORDERING CODE

(1)	(2)	(3)	(4)	(5)	(6)	(7)
HD8	-	-	/		-	/ 40

(1) HD8: 4-way directional control valve CETOP 07 - Pressure 32 MPa (320 bar)

(2) ES : electrically controlled, standard  
HH : hydraulically piloted (main body)

(3) Spool type:

-number is the main spool type

-letter is the solenoid or spring arrangement:

C : 2 solenoids spool is spring centered (3 position)

N : 2 solenoids pilot is detented (2 position)

LL : 1 solenoid (a), spool is spring/hydr. offset (2 position, end to end)

ML : 1 solenoid (a), spool is spring offset (2 position, middle to end)

LM : 1 solenoid (a), spool is spring offset (2 position, end to middle)

b : only for versions LL, MI, LM, see also functional symbols

(4) Code reserved for options and variants

C : adjustable limits for main spool stroke

D : double flow control valve to adjust shifting speed

G : adjustable limits and adjustable shifting speed

P : check valve incorporated in P port of the valve

(5) Pilot and drain arrangement

no designation: internal pilot and external drain (standard)

I : internal pilot and internal drain

E : external pilot and external drain

(6) Electric voltage and solenoid coils

0000 : no coils

012C : coils for V12DC

024C : coils for V24DC

115A : coils for V110/50 - V115/60 AC

230A : coils for V220/50 - V230/60 AC

See also electric characteristic

(7) Design number (progressive) of the valves

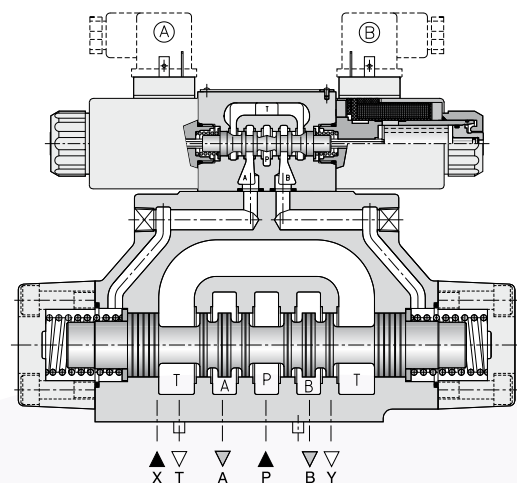
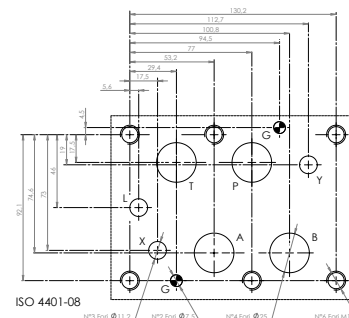

The HD8-ES solenoid operated - hydro-piloted valves are consisting of an HD3-ES type solenoid operated directional control valve (see data sheet HD3-ES) that operates a 4-way hydro-piloted control valve with a connection surface in accordance with the CETOP standards. They are available in various configurations and spool types. The pilot and the drain connections can be made internal or external by inserting or removing the accordant threaded plugs located in the main directional control valve. A wide range of configurations and different solenoid operated-hydro-piloted directional control valve spool positions are available: - 4-way, 3-position directional control valve, with two solenoids; positioning of the spool in center position is obtained with centering springs. - 4-way, 2-position directional control valve with one solenoid; positioning of the spool in center position is determined hydraulically by the pilot valve and mechanically (even without pressure) by the main stage return spring. - 4-way, 2-position directional valve, with two solenoids, with mechanical detent of the shifted pilot spool positions when solenoids are de-energized. The basic surface treatment of the valve housing is phosphate coated and the solenoids are zinc coated.

### 3 TECHNICAL DATA

Max. recommended flow (spring centering)	400 l/min
Max. recommended flow (hydraulic centering and hydraulic off set)	600 l/min
Max pressure at P, A, B ports	32 MPa (320 bar)
Max pressure at T port (internal drain)	16 MPa (160 bar)
Max pressure at T port (external drain)	25 MPa (250 bar)
Pilot pressure minimum	0,5 MPa (5 bar)
Pilot pressure Max. recommended	20 MPa (200 bar)
Mass:	
HD8-ES	approx. 15,50 Kg
HD8-HH	approx. 14,00 Kg

### 4 SPOOL IDENTIFICATION AND INTERMEDIATE POSITION TRANSITORIES

1C			67C		
0C			77C		
3C			55C		
4C			56C		
Two positions with return spring					
1LL			35C		
0LL			8C		
1ML			76C		
1LLb			65C		
0LLb					
1MLb					
Two positions with mechanical detent on pilot valve					
1N					
0N					

## 5 TYPICAL DIAGRAMS

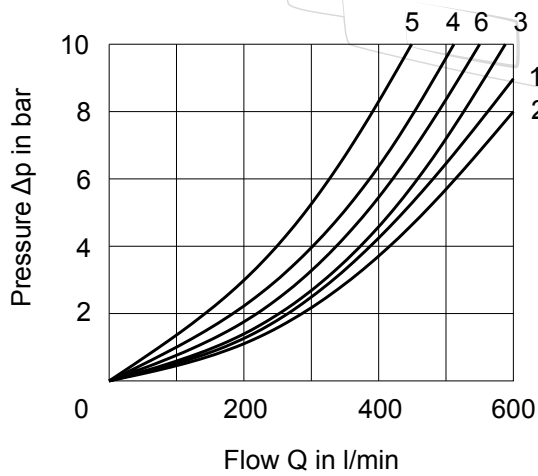

Spool type	Spool position	Connections				
		P-A	P-B	A-T	B-T	P-T
Curves on graph						
1C	Energized	1	1	2	3	
0C	De-energized	2	2	1	2	6*
3C	De-energized			4°	4°	
	Energized	1	1	1	2	
4C	De-energized			3	4	5
	Energized	6	6			
67C	De-energized		4			
	Energized	1	2	2	3	
77C	De-energized				4	
	Energized	1	1	2	2	
55C	De-energized					5°
	Energized	6	6	3	4	
56C	De-energized					5°
	Energized	6	6	4	3	
35C	Energized	1	1	2	3	
8C	De-energized	4°	4°			
	Energized	2	2	2	3	
76C	De-energized			3		
	Energized	1	1	1	3	
65C	De-energized	4				
	Energized	2	1	2	3	
1LL,OLL, 1ML	De-energized	1				
	Energized		1	2	3	
1N,ON	Energized	1	1	2	3	

## 6 INSTALLATION DIMENSION

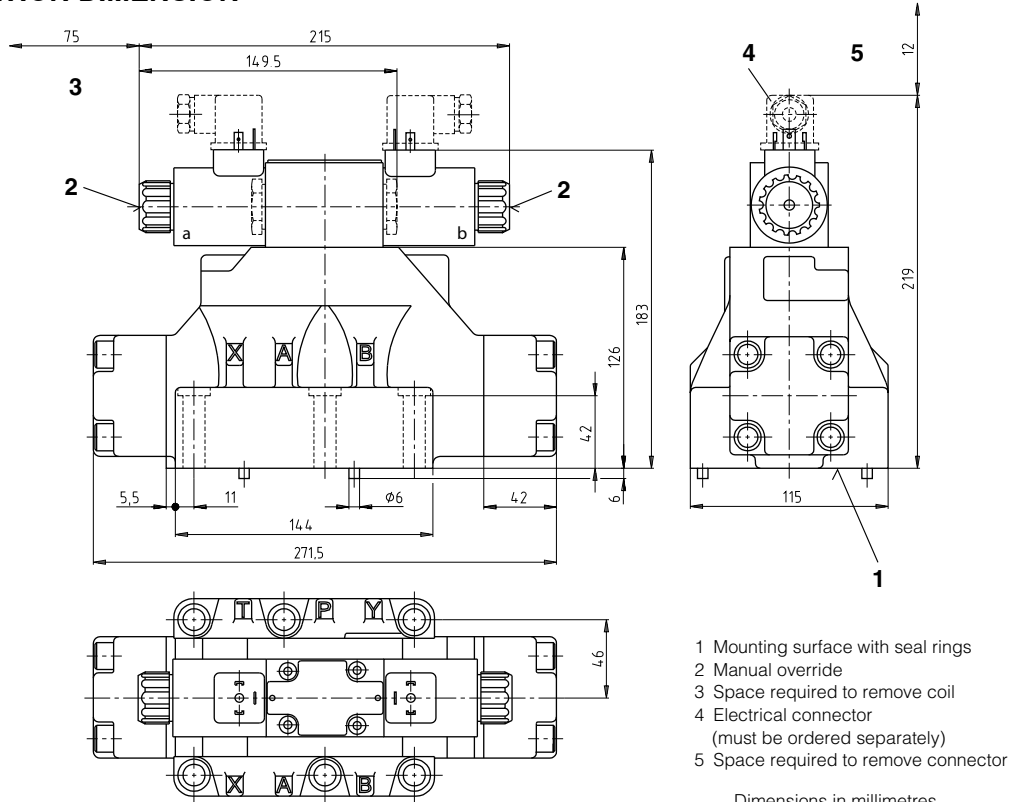

- 1 Mounting surface with seal rings
- 2 Manual override
- 3 Space required to remove coil
- 4 Electrical connector  
(must be ordered separately)
- 5 Space required to remove connector

Dimensions in millimetres

Single valve fastening:	6 bolts M12 x 60 *
Bolt torque:	69 Nm - bolts A 8.8; 1155 Nm - bolts A 12.9
Threads of mounting holes:	M12 x 20
Seal rings:	4 O-rings type 29.82 x 2.62 2 O-rings type 20.24 x 2.62

## 7 TYPE OF COMMAND

### Solenoid control: HD8-ES

The valve is supplied with a pilot solenoid valve type HD3-ES.

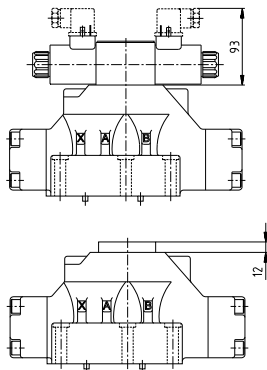

### Hydraulic control: HD8-HH

The valve is supplied as main body.

X and Y connections are used for the hydraulic control of the valve.

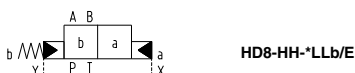
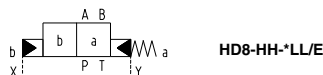
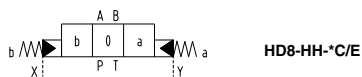

## 8 CONTROLS

### Control of the main spool stroke: C

It is possible to introduce special stroke controls in the heads of the hydropiloted valve so as to vary the maximum spool stroke. This solution allows control of the flow rate from the pump to the actuator and from the actuator to the outlet, obtaining a double adjustable control on the actuator. Add the letter **C** to the identification code to request this device.

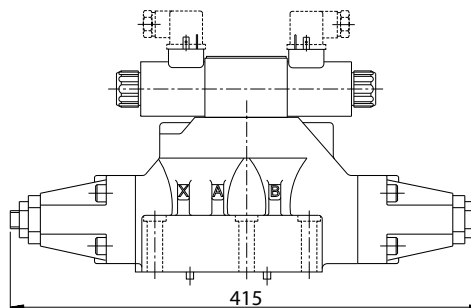

### Control of the main spool shifting speed: D

By placing a double flow control valve between the pilot solenoid valve and the hydropiloted valve, the piloted flow rate can be controlled and therefore the shifting speed can be varied. Add the letter **D** to the identification code to request this device.

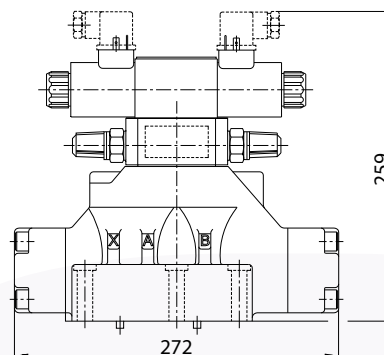

### Control of the main spool stroke and shifting speed: G

It is possible to have the valve fitted with both the spool stroke device and the piloting flow rate control device. Add the letter **G** to the identification code to request this solution.

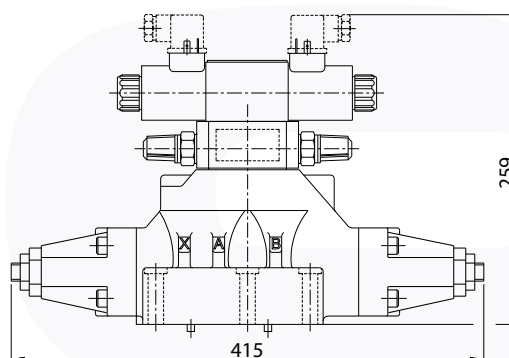

## 9 SPECIAL CONFIGURATION

### Solenoid valves with special spools

Besides the standard configurations (see pages 2 and 3), we can develop, on request, connection diagrams with special spools for a wide range of applications: consult our technical department for their identification, feasibility and operating limits.

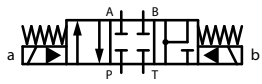

19C

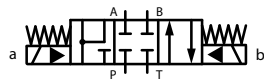

18C

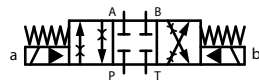

15C

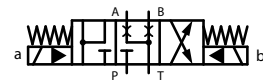

38C

### Check valve incorporated on line P: P

Valve HD8 is available upon request with check valve incorporated on line P. This is particularly useful to obtain the necessary piloting pressure when the main control valve, in the rest position, has line P connected to the T outlet. The cracking pressure is 5 bar. Add P to the identification code for this request.

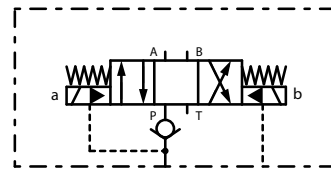

## 10 PILOT and DRAIN

The HD8 valves are available with pilot and drain, both internal and external. The version with external drain allows for a higher back pressure on the outlet.

Type of valve		Plug assembly	
		X	Y
HD8-ES-**/*	Internal pilot and external drain	NO	YES
HD8-ES-**/*I	Internal pilot and internal drain	NO	NO
HD8-ES-**/*E	External pilot and external drain	YES	YES
HD8-ES-**/*EI	External pilot and internal drain	YES	NO

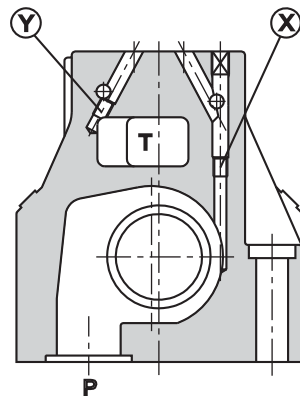

X: plug 1/16 NPT for external pilot  
Y: plug M6 x 8 for external drain





## 3 TECHNICAL DATA

Max. flow	up to 500	Hydraulic fluids: Seals and materials used on standard valves GMG*/40 are fully compatible with hydraulic fluids of mineral base, upgraded with antifoaming and anti oxidizing agents. The hydraulic fluid must be kept clean and filtered to ISO 4406 class 19/17/14, or better, and used in a recommended viscosity range from 10 cSt to 60 cSt.
Max. nominal pressure	35 MPa (350 bar)	
Ambient T	-20 + 50 °C	
Fluid T range	-20 + 80 °C	
Fluid viscosity range	10 - 400 cSt	
Recommended viscosity	10 cSt - 60 cSt	

## 4 TYPICAL DIAGRAMS

Typical P-Q curves for valves GMG\*/40 are obtained with mineral oil at viscosity 36 cSt at T = 50 °C.

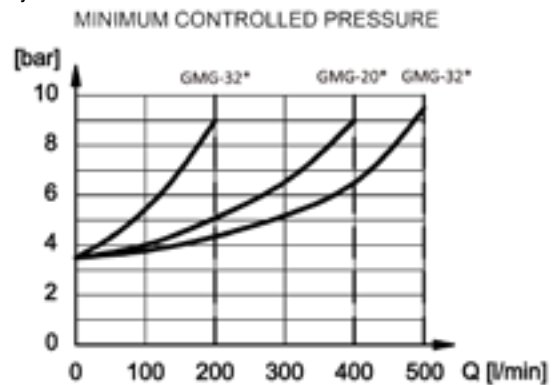
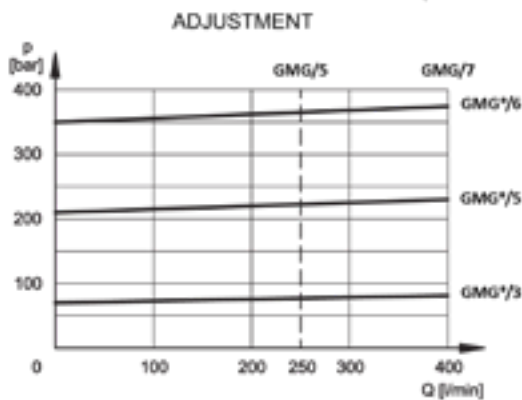

## 5 VERSIONS

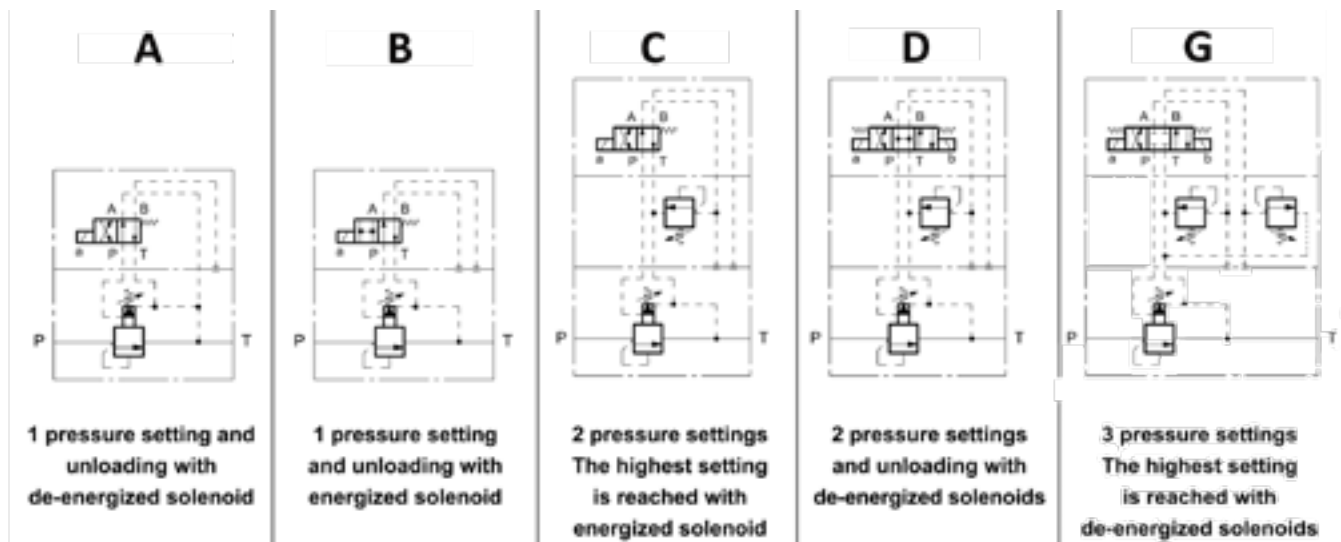

## 6 HYDRAULIC FLUIDS

Seals and materials used on standard valves GMG\*/40 are fully compatible with hydraulic fluids of mineral base, upgraded with antifoaming and anti oxidizing agents. The hydraulic fluid must be kept clean and filtered to ISO 4406 class 19/17/14, or better, and used in a recommended viscosity range from 10 cSt to 60 cSt.

## 7 INSTALLATION DIMENSIONS (mm)

dimensions are in mm

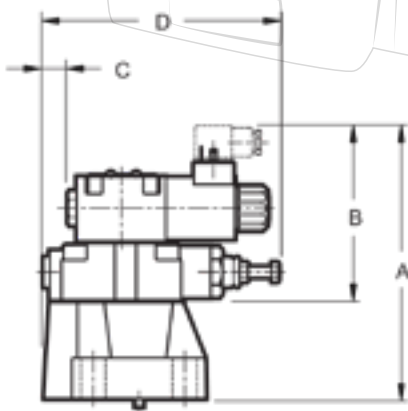

**GMG\*/A**  
**GMG\*/B**

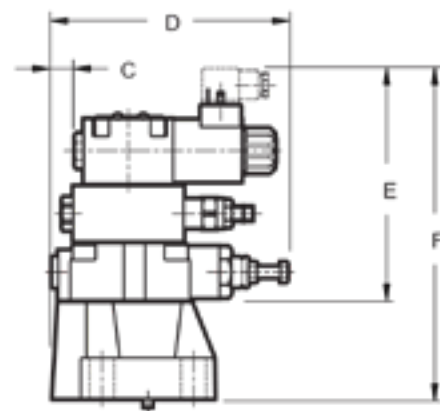

**GMG\*/C**

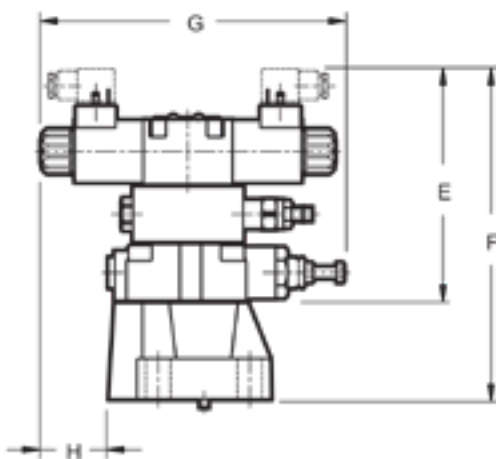

**GMG\*/D**

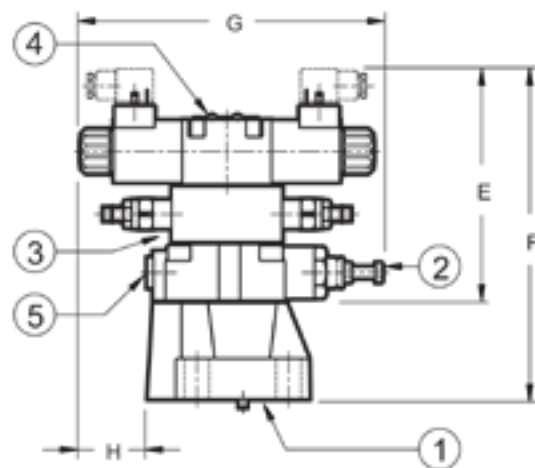

**GMG\*/G**

	A	B	C	D	E	F	G	H
GMG-10*	186	126	22	179	164	226	223	44
GMG-20*	192	126	14	170	164	236	222	52
GMG-32*	206	126	25	180	164	246	221	41

## 8 FASTENING BOLTS AND SEALING RINGS

	GMG-10*	GMG-20*	GMG-32*
Fastening (4bolts)	M 12x40	M 16x50	M 18x60
Torque	69 Nm	170 Nm	235 Nm
Sealing rings	2 OR type 123 1 OR type 109	2 OR type 3118 1 OR type 109	2 OR type 4137 1 OR type 109

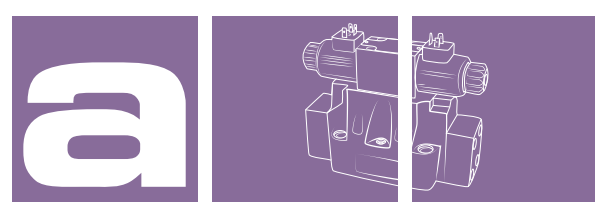

## PRESSURE RELIEF VALVE WITH UNLOADING AND PRESSURE SELECTION

### GMG\*-\* /60

400 l/min 35 MPa (350 bar)

#### 1 DESCRIPTION

Solenoid pressure relief valve with unloading and pressure selection. There are two different sizes for flow rates up to 400 l/min and 5 different configurations which permit a wide range of hydraulic configurations. The pilot valve is a CETOP 3 HD3-ES valve.



#### 2 ORDERING CODE

(1)	(2)	(3)	(4)	(5)	(6)	(7)
GMG	-	-	-	-	-	/ 60

(1) GMG: Pressure relief valve pilot operated

(2) Nominal dimensions

5: max flow rate 250 l/min

7: max flow rate 400 l/min

(3) Pressure adjustment range

3: up to 70 bar

5: up to 210 bar

7: up to 350 bar

(4) Versions: A, B, C, D, G ( see 5 )

(5) Standard - screw regulation

M - SICBLOC knob available on the main pressure control

(6) Electric voltage and solenoid coils (DIN 43650-A ISO 4400)

012C: coil(s) for V12DC

024C: coil(s) for V24DC

115A: coil(s) for V110/50 – V 115/60 AC

230A: coil(s) for V220/50 – V 230/60 AC

(7) Series number

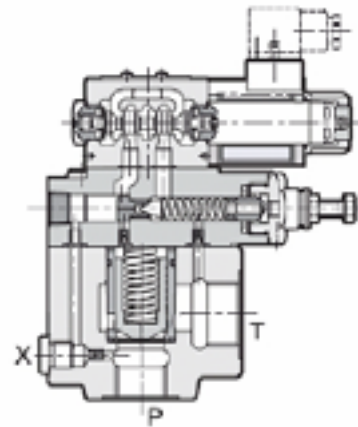

GMG\*-/60 are pilot operated pressure relief valves, available in 5 versions and up to 3 selections of pressure values. In order to set the 2nd and 3rd value, a pressure relief valve must be placed between the main body and the solenoid valve. Valves are normally supplied with a hexagonal head adjustment screw (SICBLOC adjustment knob on the main pressure control is available upon request)

### 3 TECHNICAL DATA

Max. flow	up to 400	Hydraulic fluids: Seals and materials used on standard valves GMG*/60 are fully compatible with hydraulic fluids of mineral base, upgraded with antifoaming and anti oxidizing agents. The hydraulic fluid must be kept clean and filtered to ISO 4406 class 19/17/14, or better, and used in a recommended viscosity range from 10 cSt to 60 cSt.
Max. nominal pressure	35 MPa (350 bar)	
Ambient T	-20 + 50 °C	
Fluid T range	-20 + 80 °C	
Fluid viscosity range	10 - 400 cSt	
Recommended viscosity	10 cSt - 60 cSt	

### 4 TYPICAL DIAGRAMS

Typical P-Q curves for valves GMG\*/60 are obtained with mineral oil at viscosity 36 cSt at T = 50 °C.

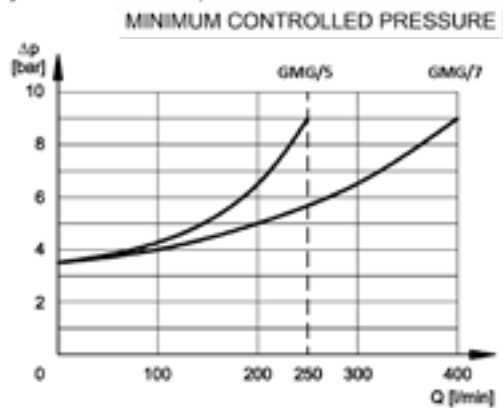
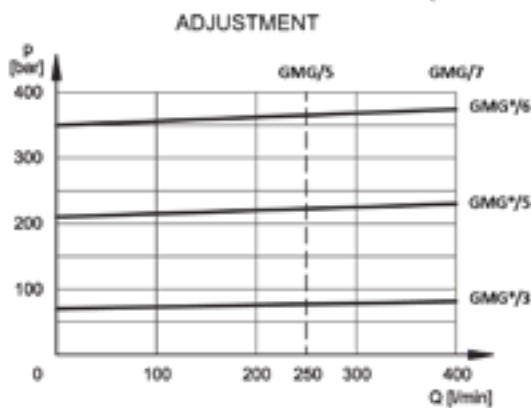

### 5 VERSIONS

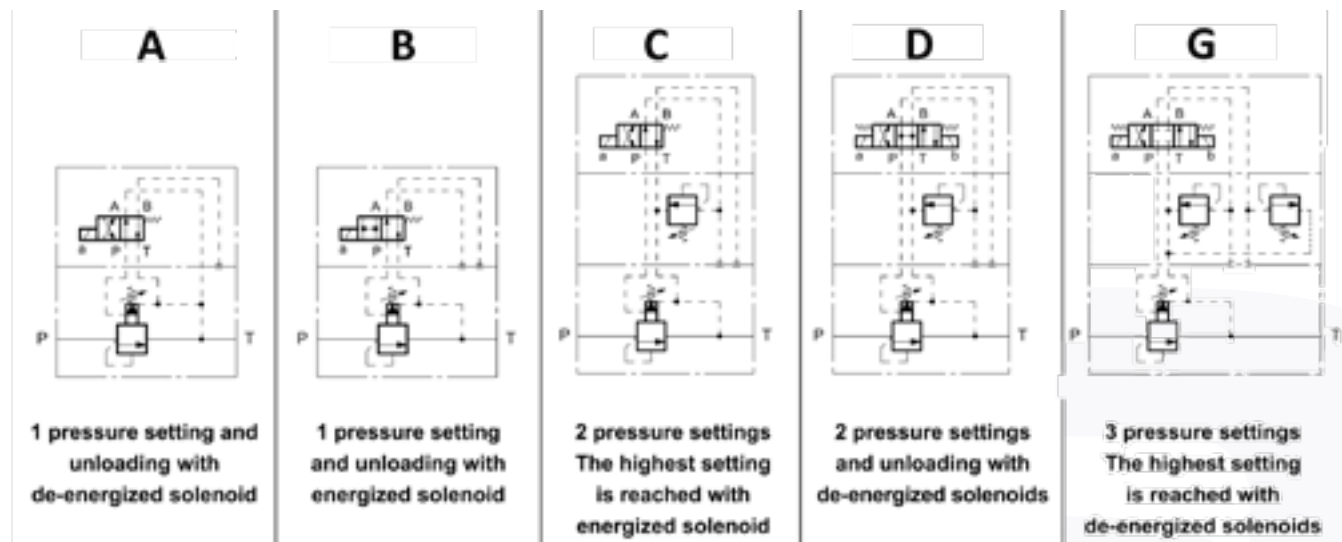

## 6 INSTALLATION DIMENSIONS

GMG\*/A  
GMG\*/B

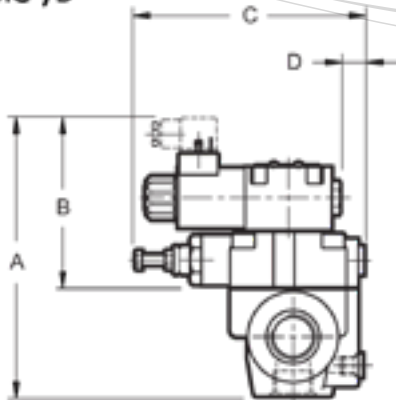

GMG\*/C

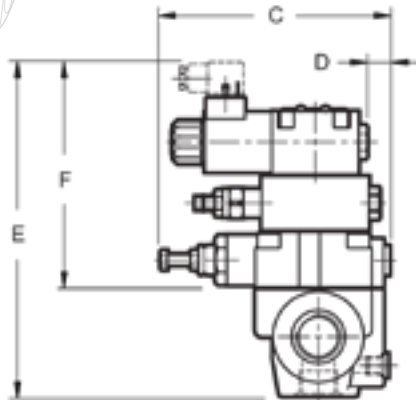

GMG\*/D

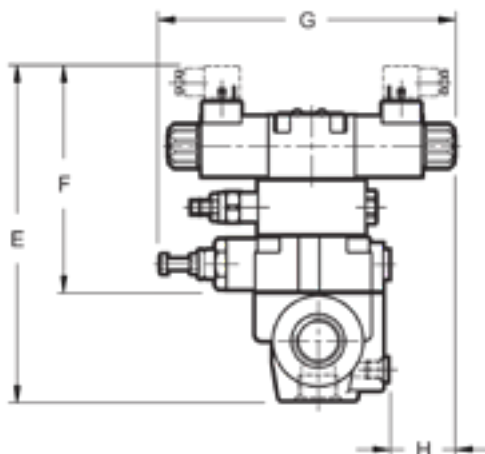

GMG\*/G

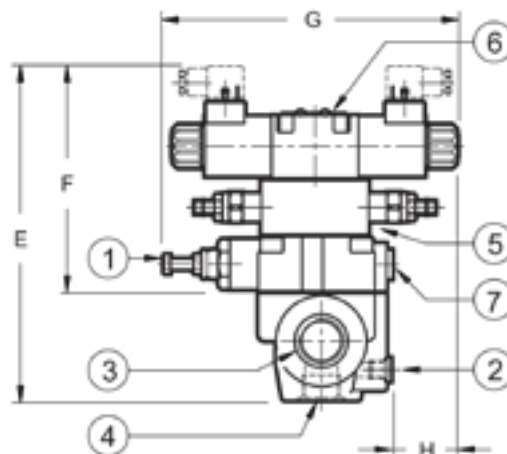

	A	B	C	D	E	F	G	H
GMG-5*	186	126	22	179	164	226	223	44
GMG-7*	192	126	14	170	164	236	222	52





## 7 HYDRAULIC FLUIDS

Seals and materials used on standard valves GMG\*/60 are fully compatible with hydraulic fluids of mineral base, upgraded with antifoaming and anti oxidizing agents. The hydraulic fluid must be kept clean and filtered to ISO 4406 class 19/17/14, or better, and used in a recommended viscosity range from 10 cSt to 60 cSt.



# SUMMARY



<b>DIRECTIONAL CONTROL VALVES- CETOP 03</b>  <b>proof II 2 GD, Ex d IIC T5</b> <b>HD3 - EX - *</b>	<b>0001</b>
<b>HYDRAULIC SCREW-IN VALVES</b>  <b>proof II 2 GD, Ex d IIC T5</b> <b>EVX-*-C5</b>	<b>0005</b>
<b>HYDRAULIC SCREW-IN VALVES</b>  <b>proof II 2 GD, Ex d IIC T5</b> <b>EVX-06-D5</b>	<b>0007</b>
<b>PROPORTIONAL 4-WAY CONTROL VALVES</b>  <b>- proof II 2 GD, Ex d IIC T5</b> <b>HD3-PX</b>	<b>0009</b>
<b>DIRECTIONAL CONTROL VALVES</b>  <b>- proof II 2 GD, EEx d IIC T5</b> <b>HD5-EX</b>	<b>0013</b>

# DIRECTIONAL CONTROL VALVES– CETOP 03 proof II 2 GD, Ex d IIC T5

## HD3-EX-\*

### 40 l/min 25 MPa (250 bar)

## 1 DESCRIPTION

Valves HD3-EX are ATEX directional control valve solenoid operated with subplate mounting interface acc. to ISO 4401, DIN 24340 (CETOP 03).

The design of the body is an high quality five chamber casting. The valve is available with ATEX metallic DC and AC solenoids. In the standard version, the valve housing is phosphated for 240 h salt spray protection acc. to ISO 9227 . Enhanced surface protection for specific applications is available (ISO 9227, 520 h salt spray).



## 2 ORDERING CODE

(1)	(2)	(3)	(4)	(5)	(6)
HD3	-	EX	-	-	/ 25

(1) HD3 : 4-way directional valve Cetop 03 – Pressure 25 Mpa (250 bar)

(2) EX : electrically controlled, Ex-proof solenoid

(3) Spool type (see 4):

-number is the main spool type

-letter is the solenoid or spring arrangement:

C : 2 solenoids spool is spring centered (3 position)

N : 2 solenoids spool is detented (2 position) see 9

LL : 1 solenoid (a), spool is spring offset (2 position, end to end)

ML: 1 solenoid (a), spool is spring offset (2 position, middle to end)

LM: 1 solenoid (a), spool is spring offset (2 position, end to middle)

(4) Code reserved for option and variants

b: only for LL, ML, LM sol. b installed (instead of sol. a)

S-\*\*: calibrated orifice on P port, see 10

ZT: zinc trivalent plated valve, see 11

(5) Electric voltage and solenoid coils

012C: coil(s) for V12DC

024C: coil(s) for V24DC

110A: coil(s) for V110/50 – V115/60 AC

230A: coil(s) for V220/50 – V230/60 AC

(6) Design number of the valves Atex solenoid for G and D

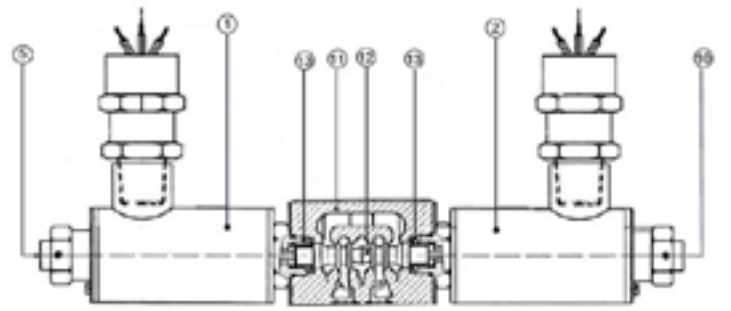
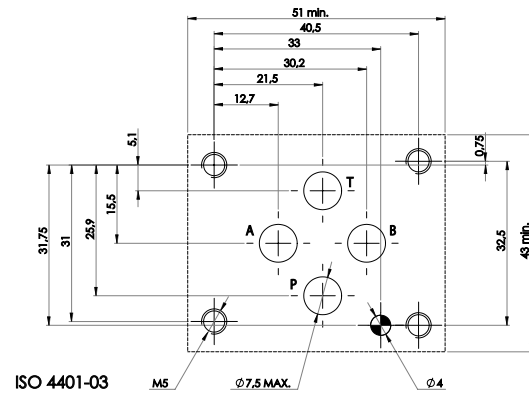

The spool 12 shifts into the valve body 11 subject to the action of springs 13 and solenoids 2. Spool 12, depending from its shape and its position in the valve body, opens and/ or closes passages between P, A, B and T ports, thus controlling the direction of the hydraulic flow.



### 3 TECHNICAL DATA

Nominal flow	32 l/min	<b>Electric Characteristics:</b> Valves type HD3-EX-* are operated by solenoid that are energized: • directly from a D.C. voltage supply: V 12 DC = 012 C V 24 DC = 024 C • by the use of coils that incorporate a full wave bridge rectifier, from A.C. voltage supply: V 110/50-V 115/60 = 110 A V 220/50-V 230/60 = 230 A Other voltages are available. Permissible supply voltage variation: + 5%. Ex-proof solenoid according to ATEX 94/9/EC,  II 2GD, class Exd IIC T5 – see <a href="#">7</a> Power consumption: max 11 w. Currents are, at nominal voltage and at 25°C: V12DC = 0,92A V115AC = approx 0,1A V24DC = 0,46A V230AC = approx 0,05A
Maximum rec. flow rate	40 l/min	
Maximum nominal pressure (P,A,B)	25 MPa (250 bar)	
Maximum pressure at T port	25 MPa (250 bar)	
Pressure drops	See <a href="#">5</a>	
Protection to DIN 40050	IP 67	
Duty cycle	100%	
Service life	≥ 10 <sup>7</sup> cycles	
Dimensions and Installation	see <a href="#">6</a>	
Mass	Approx 2,6 / 3,7 kg	

### 4 SPOOL IDENTIFICATION AND INTERMEDIATE POSITION TRANSITORIES

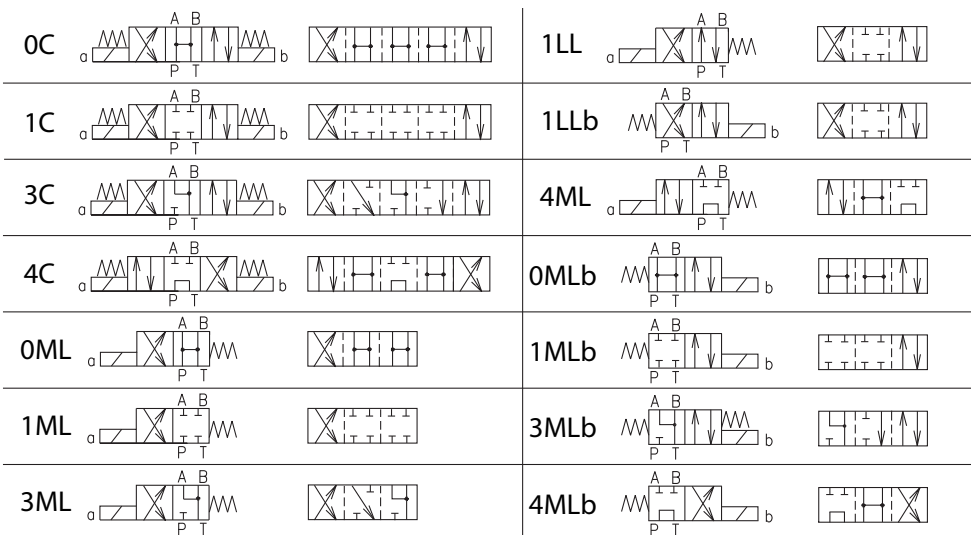

Spools, springs and solenoids combination permit to obtain almost every type of ports (P, A, B, T) connection and sequence. For almost all types of solenoids/springs combination and for all type of spools (with the exceptions of spool 4), when solenoid “a” is energized, hydraulic connections are P-> B and A ->T; to obtain P -> A and B-> T solenoid “b” must be energized. The hydraulic connections that are obtained in the “central” (neutral) position when solenoids are not energized is the characteristic mark of the spool shape and from it derives its identification number:

- 0 = P, A, B, T connected
- 1 = P, A, B, T closed
- 3 = P closed, A, B, T, connected.

### 5 TYPICAL DIAGRAMS

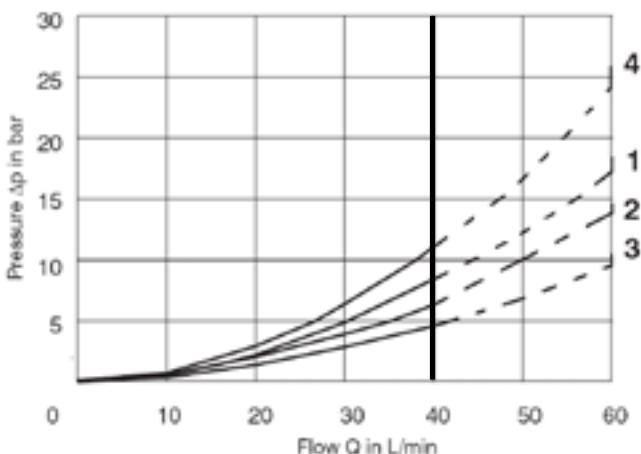

	P-A	P-B	A-T	B-T	P-T
1C	2	2	2	2	-
4C	4	4	4	4	2
0C	2	2	3	3	2
3C	2	2	3	3	-
1LL	3	3	4	4	-
1LLb	3	3	4	4	-
1ML	-	2	2	-	-
4ML	4	-	-	4	2
0ML	2	-	-	3	2
3ML	2	-	-	2	-

## 6 INSTALLATION DIMENSIONS

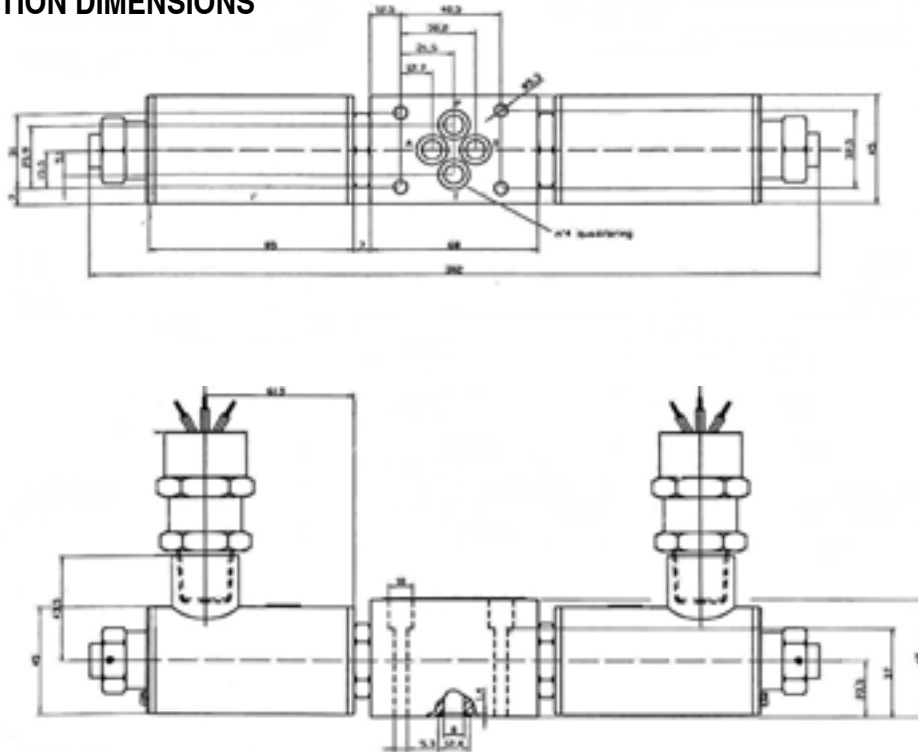

All valves HD3-\* conform with ISO and CETOP specifications for mounting surface dimensions (see also front page) and for valves height. When assembled to its mounting plate valve HD3-\* must be fastened with 4 bolts M5 X 45 mm (or M5 x \*\* according to the number of modules) tightened at 8 Nm torque. Leakage between valve and mounting surface is prevented by the positive compression on their seats of 4 seals of QUAD/O Ring type 9,25x1,68x1,68.

## 7 EXPLOSION PROOF SOLENOID GMA-6/HD SERIES 271 GD

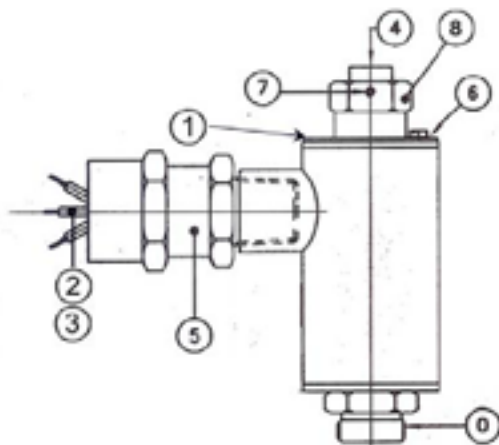

Atex Certificates :  
INERIS 05ATEX0028X/02 for Gas and Dust

0: Ex proof solenoid according to ATEX 94/9/EC.  
II 2GD Exd IIC T5.

Solenoid outside surfaces are zinc-nickel plated, with 7 minimum thickness  
1: Solenoid label indicates supply voltage, protection class Exd, certification number by INERIS and maximum absorbed power.

2: 3-wires cable, according to CEI 20-22, of standard length of 1,5 m, is fastened to the coil and locked by cable gland.

3: Wires have 1,5 mm<sup>2</sup> section; earth connection wire is green-yellow. Electric connection must be in accordance with Ex-proof norm ATEX.

4: Manual override operation is by pushing the extended pin.

5: Normalised cable gland –torque 8 Nm + 1 – device has threaded attachment 1/2" conical – ISO 7/1

6: Earth connection screw

7: Threaded plug (socket hexagon 1,5 mm) to lock the retaining coil nut

8: Nut for retaining the coil –torque 6 Nm + 1 – hexagon 24 mm.

**Conformity of unit to the norms is not granted if coil is used separately from its electromagnetic tube.**

## 8 HYDRAULIC FLUIDS

Seals and materials used on standard valves HD3-\* are fully compatible with hydraulic fluids of mineral oil base, upgraded with antifoaming and anti-oxidizing agents. The hydraulic fluid must be kept clean and filtered to ISO 4406 class 19/17/14, or better, and used in a recommended viscosity range from 10 cSt to 60 cSt.

## 9 VERSION "N": MECHANICAL DETENT ON SPOOL

Solenoid valves with detent typically are 2 position, 2 solenoid, nospring valve where the spool is kept at the extreme ends of its stroke by a mechanical device. This permits that solenoids are energized by short time current pulses and that the spool remains at its position regardless of forces due to hydrodynamics or gravitational/inertial effects (vibrations).

## 10 VERSION "S\*": CALIBRATED ORIFICE ON P PORT

Option "S\*" is represented by elements , suitably shaped to be inserted on P port of the solenoid valve, having a calibrated orifice (of various sizes) able to restrict, at the requested P value, the flow rate entering the solenoid valve. Those elements have the following orifice diameter:

3S - 10  $\varnothing D = 1 \text{ mm}$

3S - 20  $\varnothing D = 2 \text{ mm}$

3S - 25  $\varnothing D = 2,5 \text{ mm}$

and are kept sealed on the P port of the valve by an OR of 9,25x1,78 mm sizes (example OR 110 - 2037).

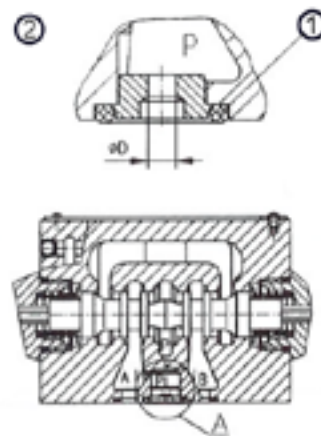

## 11 VERSION "ZT": ZINC PLATED VALVES

Solenoid valves according to "ZT" version have central body zinc trivalent plated and protected against every type of corrosion due to saline ambiance or other aggressive chemicals. Zinc thickness are on the valve body: 10-15  $\mu\text{m}$ .

# HYDRAULIC SCREW-IN VALVES proof II 2 GD, Ex d IIC T5

## EVX-\*-C5

### 25 l/min 25 MPa (250 bar)

#### 1 DESCRIPTION

Valves EVX-\*-C5 are ATEX directional control valve in cartridge style poppet type. It is suitable for 2 way metric cavity M22 x 1,5 or cavity SAE 08 . The valve is available with ATEX metallic DC and AC solenoids. The coil is Zinc-nichel coated for an enhanced surface protection (ISO 9227, 520 h salt spray).

Protection according to IEC 144: Class IP67- External surfaces zinc-nichel coated (min. thickness 7 micron)

Connection: 3,5 mm<sup>2</sup> wire cable (CEI 20-22), length 1,5 m already connected to coil. Electrical connection must be accordance to Ex-proof norm ATEX. Earth connection both internal, with yellow-green wire in the cable, and external with a minimum 4mm<sup>2</sup> cable fastened to earth screw.



#### 2 ORDERING CODE

(1)	(2)	(3)	(4)
EVX	-	-	C5

(1) EVX: Ex-proof solenoid operated screw-in poppet valve

(2) Size:

06: metric cavity M22x1,5 See [5](#)

34: SAE 08 cavity 3/4" 16 UNF See [5](#)

(3) C5: two way type

(4) Coils:

012C: 12V DC-0,92A

024C: 24V DC-0,46A

115A: 115V AC-0,10A

230A: 230V AC-0,05A

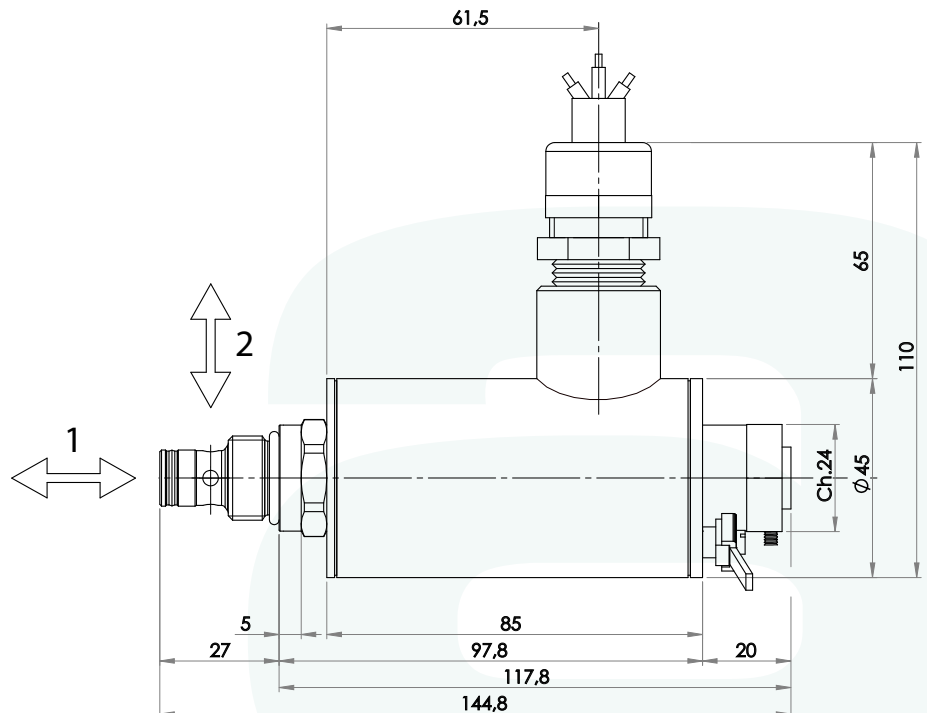
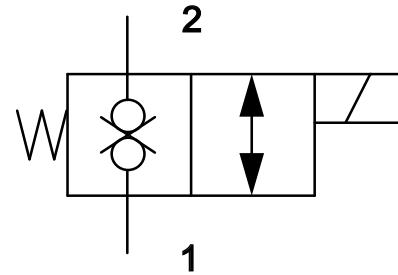

### 3 TECHNICAL DATA

Suitable for standard cavity:	M22 x 1,5 or SAE 08
Solenoids according to ATEX 94/9/CE and conform to EN 50281-1-1	
ATEX code/class:	II 2 GD Ex d II C T5
Certificate:	INERIS 05ATEX0028X/02
Max. operating pressure:	250 bar
Max. flow rate:	25 l/min
Duty cycle:	100%
Materials:	Steel body, poppet in tempered and grinded steel
Mass	1,40 kg (coil included)

### 4 TYPICAL DIAGRAMS

Typical  $\Delta p$ -Q curves for valves EVX-\*-C5 in standard configuration, with mineral oil at 26 cSt and 50 °C

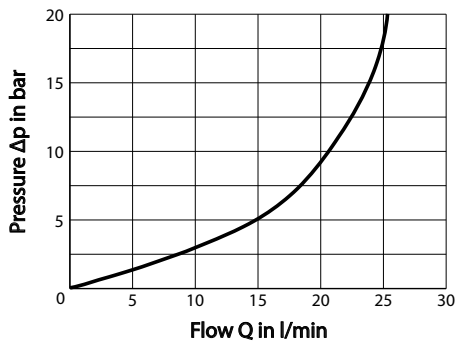

Typical p-Q curves of operating limits for maximum hydraulic power transferred by valves EVX-\*-C5

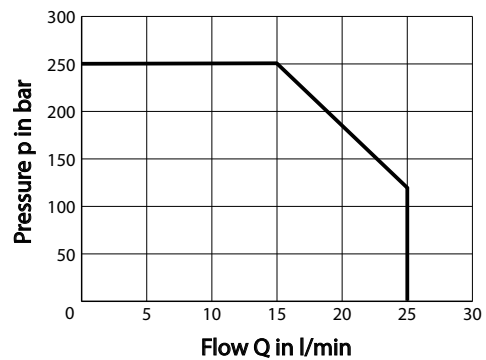

### 5 INSTALLATION DIMENSIONS (mm)

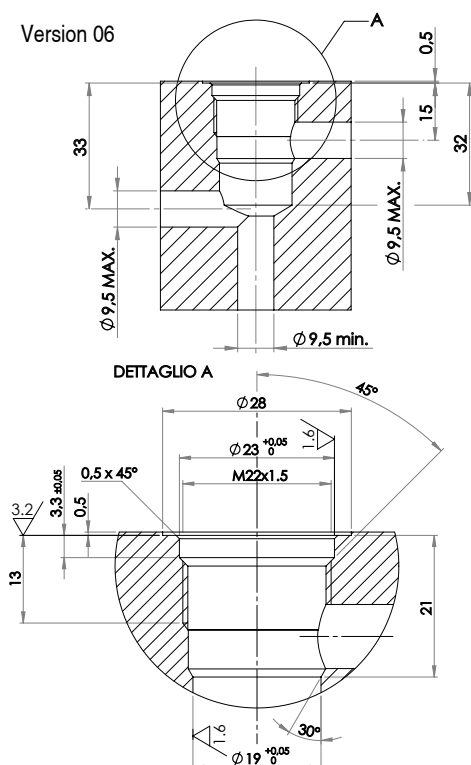

# HYDRAULIC SCREW-IN VALVES proof II 2 GD, Ex d IIC T5

## EVX-06-D5

25 l/min 25 MPa (250 bar)

### 1 DESCRIPTION

Valves EVX-06-D5 are ATEX directional control valve in cartridge style poppet type. It is suitable for a 3 way metric cavity M22 x 1,5. The valve is available with ATEX metallic DC and AC solenoids. The coil is Zinc-nichel coated for an enhanced surface protection (ISO 9227, 520 h salt spray). Protection according to IEC 144: Class IP67- External surfaces nickel coated (min. thickness 7 microm) Connection: 3X1,5mm<sup>2</sup> wire cable (CEI 20-22), length 1,5m already connected to coil. Electrical connection must be accordance to Ex-proof norm ATEX. Earth connection both internal, with yellow-green wire in the cable, and external with a minimum 4mm<sup>2</sup> cable fastened to earth screw.



### 2 ORDERING CODE

(1)	(2)	(3)	(4)
EVX	- 06	- D5	-

- (1) EVX: Ex-proof solenoid operated screw-in poppet valve
- (2) 06: normal port size
- (3) D5: three way type
- (4) Coils:
  - 012C: 12V DC-0,92A
  - 024C: 24V DC-0,46A
  - 115A: 115V AC-0,10A
  - 230A: 230V AC-0,05A

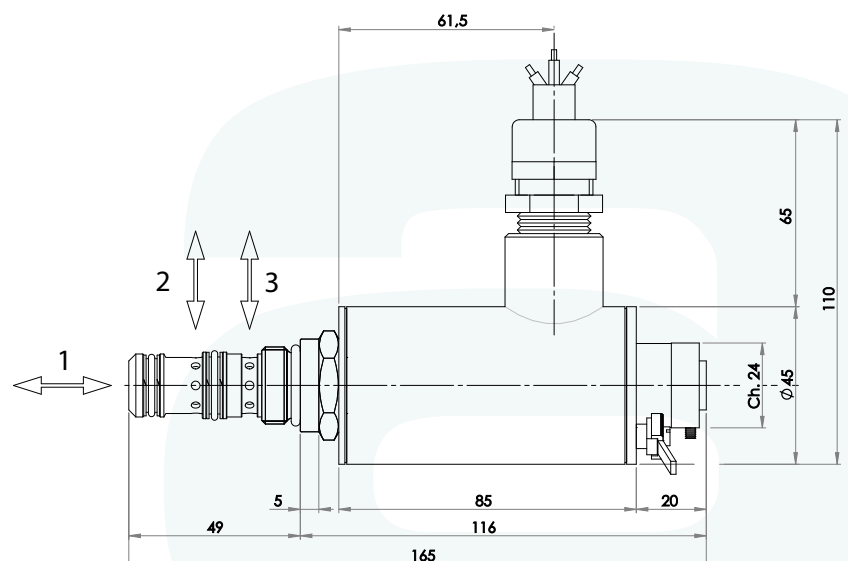
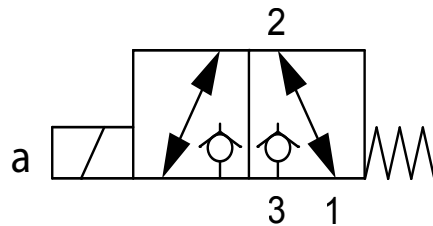

### 3 TECHNICAL DATA

Suitable for standard cavity:	M22 x 1,5
Solenoids according to ATEX 94/9/CE and conform to EN 50281-1-1	
ATEX code/class:	II 2 GD Ex d II C T5
Certificate:	INERIS 05ATEX0028X/01 (on request)
Max. operating pressure:	250 bar
Max. flow rate:	25 l/min
Duty cycle:	100%
Materials:	Steel body, poppet in tempered and grinded steel
Mass	1,45 kg (coil included)

### 4 TYPICAL DIAGRAMS

Typical  $\Delta p$ -Q curves for valves EVX-06-D5 in standard configuration, with mineral oil at 26cSt and 50 °C

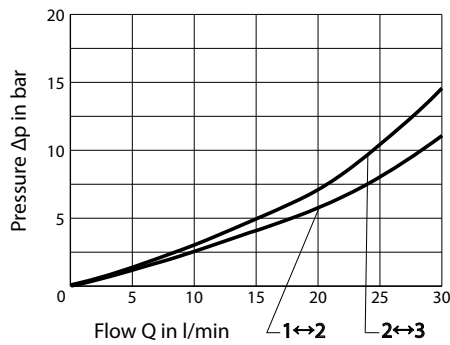

Typical p-Q curves of operating limits for maximum hydraulic power transferred by valves EVX-06-D5. Input voltage 10% less than nominal rate.

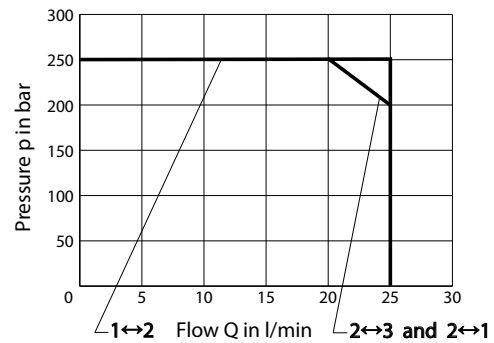

### 5 INSTALLATION DIMENSIONS (mm)

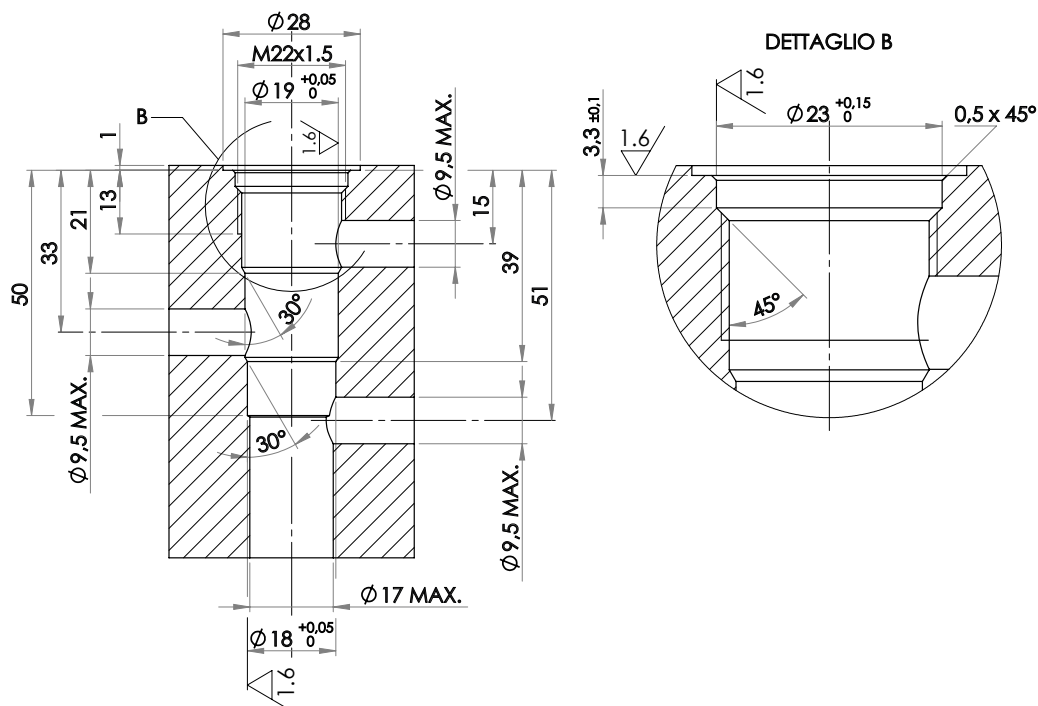

# PROPORTIONAL 4-WAY CONTROL VALVES $\text{Ex}$ - proof II 2 GD, Ex d IIC T5

## HD3-PX

32 l/min 25 MPa (250 bar)

### 1 DESCRIPTION

Valves HD3-PX are ATEX proportional directional control valve with subplate mounting interface acc. to ISO 4401, DIN 24340 (CETOP 03). The design of the body is an high quality five chamber casting. The valve is available with ATEX metallic DC and AC solenoids. In the standard version, the valve housing is phosphated for 240 h salt spray protection acc. to ISO 9227. Enhanced surface protection for specific applications is available (ISO 9227, 520 h salt spray).



### 2 ORDERING CODE

(1)	(2)	(3)	(4)	(5)	(6)	(7)
HD3	-	PX	-	-	-	/

(1) HD3: : 4-way directional valve Cetop 03 – Pressure 25 Mpa (250 bar)

(2) PX : Proportional electric control, Ex-proof solenoid (see 7)

(3) Functional spool type (see 5)

- number:

1 : closed center (P, A, B, T blocked)

3 : P blocked, A, B, T connected

-spool nominal flow:

P : 32 l/min with P = 1 Mpa (10 bar) (PA+BT or PB+AT)

R : 16 l/min with P = 1 Mpa (10 bar) (PA+BT or PB+AT)

05 : 05 l/min with P = 1 Mpa (10 bar) (PA+BT or PB+AT)

D : differential  $Q_b = 2Q_a$ : 32/16 l/min with P = 1 Mpa (10 bar)

(4) Solenoids and springs arrangements (see 5)

C : 2 sol., spool is springs centered

ML : 1 sol. ("a") spool is centered + 1 end position

MLb : 1 sol. ("b") spool is centered + 1 end position

(5) Options and variants

ZC : zinc plated valves (see 10)

(6) Type of coil(s) and supply voltages (see 7)

R2 : standard V12DC (R=11,3 )

R4 : standard V24DC (R=45,3 )

(7) Design number (progressive) of the valve.

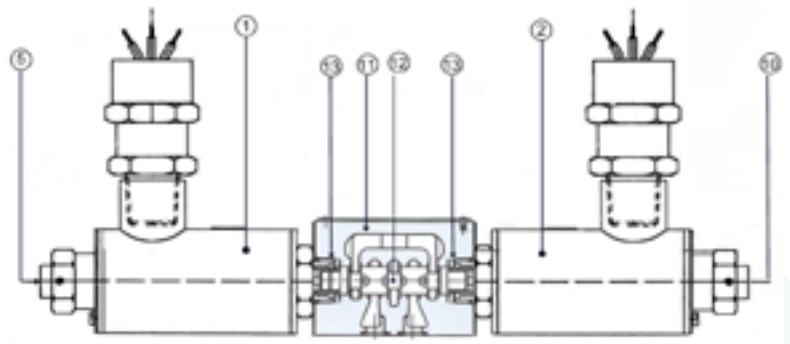
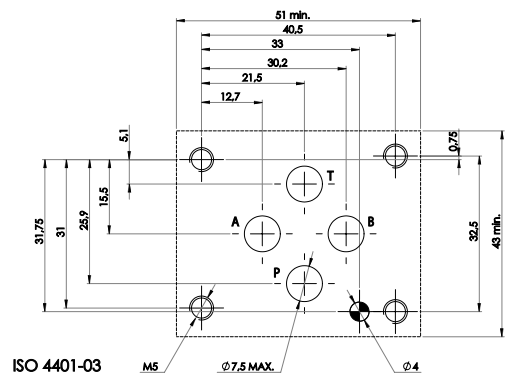

The spool 12 shifts in to the valves body 11 subject to the action of springs 13 and proportional solenoids 1 and 2. Spool 12, depending from its shape and its position in the valves body 11, opens and/or closes passages between P, A, B, T ports, thus controlling the direction and the rate of the hydraulic flow. Solenoids 1 and 2 and are energized by electric current flowing-in through cables; in case of electric cut-offs, the spool can be manually shifted by acting on the emergency pins, located at the end of the solenoids and accessible through the retaining nuts.



## 3 TECHNICAL DATA

Nominal flow rates	5, 16, 32 l/min	<b>Electric characteristics:</b> Valves type HD3-PX-* are valves operated by Ex-proof proportional solenoids ATEX qualified for class EExd IIc T5 – see 9. <b>On valves type HD3-PX-*, the max permissible power consumption on each solenoid is 11w and, therefore, the currents to solenoids have to be limited to:</b> • I max = 0,92 A for coils R2 (R=11,3) • I max = 0,46 A for coils R4 (R=45,3)  Currents to hydraulic proportional valves are normally supplied by an electronic driver based on PWM mode of operation, capable of full control of min and max values of current – see 14.
Maximum nominal pressure (P,A,B)	25 Mpa (250 bar)	
Maximum pressure at T port	25 Mpa (250 bar)	
Maximum rec. Pressure drops	5 Mpa (50 bar) (see 5)	
Protection to DIN 40050	IP 67	
Duty cycle	100%	
Service life	> 10 <sup>7</sup> cycles	
Dimensions and installation	(see 8)	
Mass	Approx 2,6 / 3,7 kg	

## 4 TYPICAL DIAGRAMS

Typical flow curves of valves HD3-PX-\* in standard configuration measured with mineral oil at 36 cSt and at 50°C at ΔP=01 Mpa (10 bar) for flow P → B, A → T

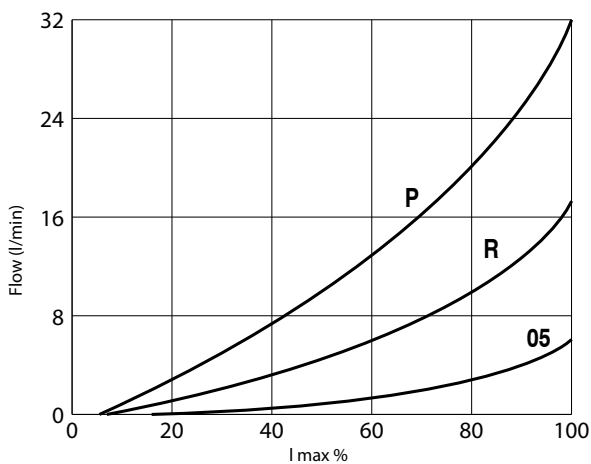

## 6 FLOW RATES AND PRESSURE DIFFERENTIAL

For a given ΔP on a given valve the flow rates are proportional to the driving current (see 4); for a given driving current on a given valve, the flow rates increase with the increasing of the ΔP up to certain limits. Typical limit curves are:

## 5 SPOOL IDENTIFICATION AND INTERMEDIATE POSITION TRANSITORIES

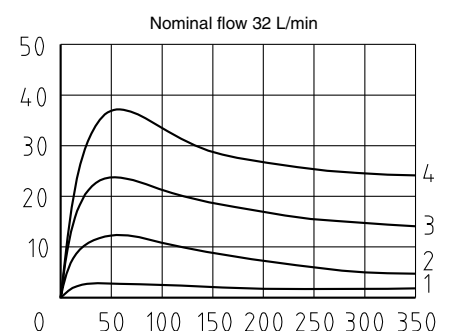
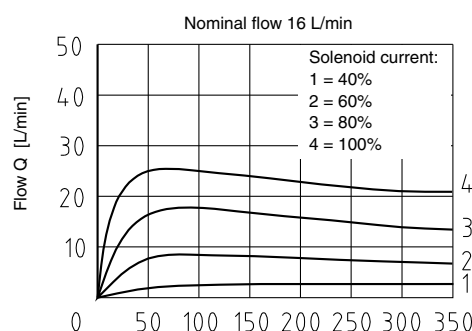
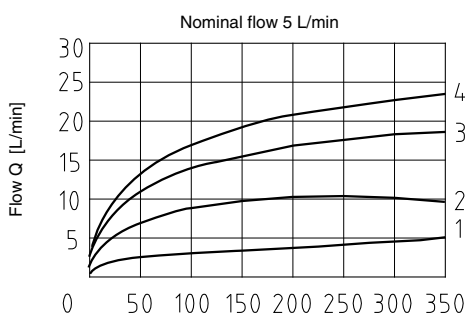
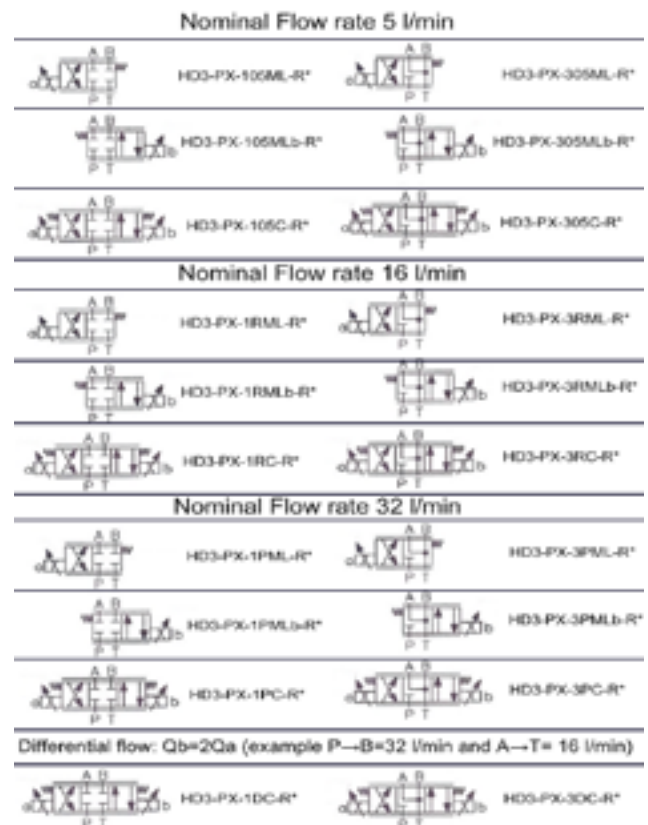



## 9 HYDRAULIC FLUIDS

Seals and materials used on standard valves HD3-\* are fully compatible with hydraulic fluids of mineral oil base, upgraded with antifoaming and anti-oxidizing agents. The hydraulic fluid must be kept clean and filtered to ISO 4406 class 19/17/14, or better, and used in a recommended viscosity range from 10 cSt to 60 cSt.

## 10 VERSION "ZC": ZINC PLATED VALVES

Solenoid valves according to "ZC" version have central body zinc plated and protected against every type of corrosion due to saline ambiance or other aggressive chemicals. Zinc thickness are on the valve body: 10-15  $\mu$ m.

## 11 PRESSURE COMPENSATOR MODULES

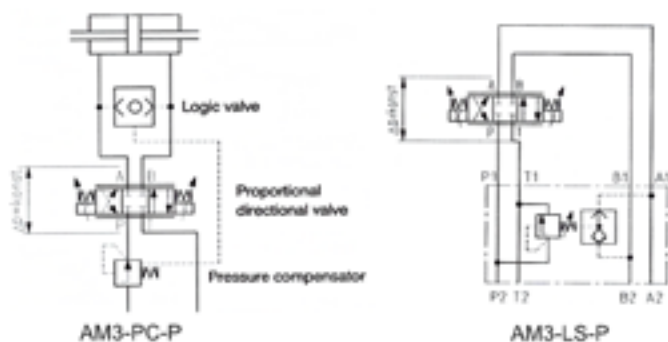

2-way pressure compensator for meter-in application type AM3-PCP – see table AM-391. When using the 2-way pressure compensators in meter-in application, shown in the circuit diagram, a constant pressure difference across the metering edge of the proportional direction valve is held. In this case, the pressure variations due to loading changes, as well as pump pressure changes, are compensated. That means that a pressure change cannot result in flow increase. 3-way pressure compensator type AM3-LS-P is able to operate as "load sensing" device, by discharging at T port, at the same pressure of the user, the flow that exceeds the flow rates required by the controlled opening of the proportional 4-way valve.

# DIRECTIONAL CONTROL VALVES - proof II 2 GD, EEx d IIC T5

## HD5-EX

### 150 l/min 32 MPa (320 bar)

## 1 DESCRIPTION

HD5-EX-\*\* Ex proof electrically are pilot operated 4 way valves of size ISO 05 with mounting surface according to Cetop 4.2-4 P05-320  
 Characteristics of the Ex proof, electrically operated, pilot valve type HD3-EX-\*\* are described on Aidro table HD-3EX rev.

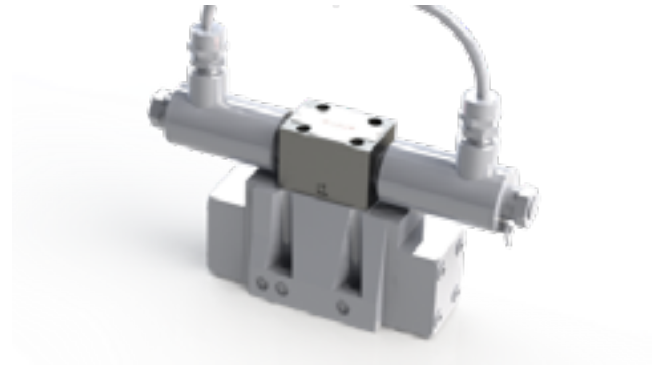

## 2 ORDERING CODE

(1)	(2)	(3)	(4)	(5)	(6)	(7)	(8)
HD5	-	EX	-	-	-	-	/ 40

(1) HD5: 4-way directional control valve Cetop 05- Pressure 32 MPa (320 bar)

(2) Variants:

- EX: electrically controlled, EX Proof ATEX
- HH: hydraulically piloted (main body)

(3) Spool type:

- number is the main spool type
- letter is the solenoid or spring arrangement:
  - C : 2 solenoids, spool is spring centered (3 position)
  - LL : 1 solenoid (a), spool is spring/hydr. offset (2 position, end to end)
  - ML: 1 solenoid (a), spool is spring offset (2 position, middle to end)
  - LM: 1 solenoid (a), spool is spring offset (2 position, end to middle)
- b: only for versions LL, ML, LM see also functional symbols

(4) Location of X and Y ports.

- no designation: standard, according to CETOP 4.2-4 P05-320
- R05: according to CETOP 4.2-4R05-320 and ISO/ CD 4401-05

(5) Code reserved for options and variants

- C: adjustable limits for main spool stroke
- D: double flow control valve to adjust shifting speed
- G: adjustable limits and adjustable shifting speed

(6) Pilot and drain arrangement

- no designation: internal pilot and external drain (standard)
- I : internal pilot and internal drain
- E: external pilot and external drain

(7) Electric voltage and solenoid coils

- 012C : coils for V12DC
- 024C : coils for V24DC
- 115A : coils for V110/50 - V 115/60 AC
- 230A : coils for V220/50 - V 230/60 AC
- See also electric characteristics

(8) Design number (progressive) of the valves

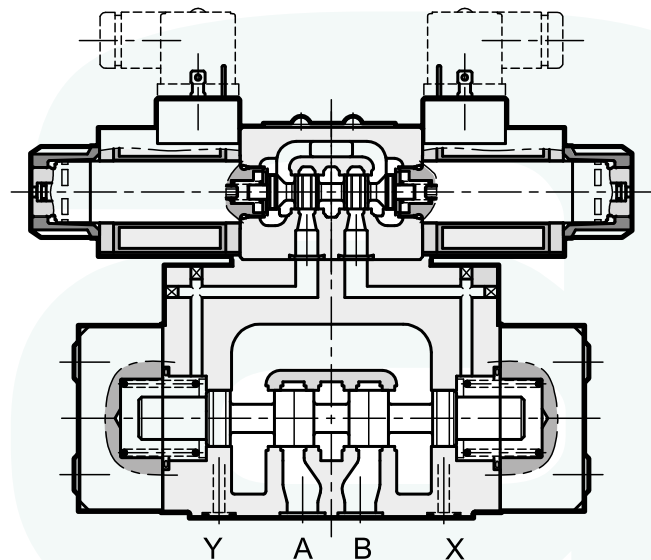
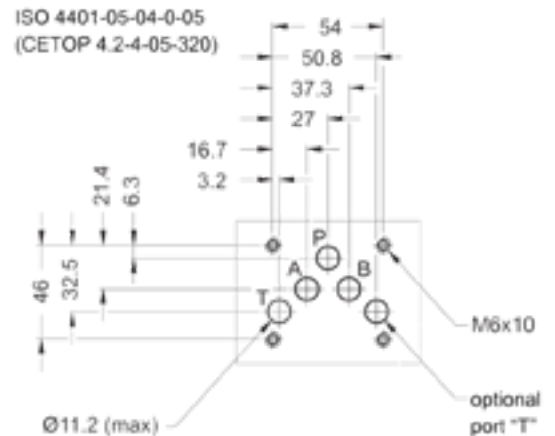

### 3 TECHNICAL DATA

max recommended flow (spring centering)	150 l/min	Note: When valves HD5-EX-** are made with internal pilot and internal drain ("I" configuration), ports X and Y are not used and valves can be installed on normal 05 surface mounting plates according to ISO 4401-05.
Maximum pressure (P,A,B)	32 MPa (320 bar)	
Maximum pressure at T port (internal drain)	16 MPa (160 bar)	
Maximum pressure at T port (external drain)	25 MPa (250 bar)	
Pilot pressure minimum	0,5 MPa (5 bar)	
Pilot pressure maximum recommended	20 MPa (200 bar)	
Dimensions and installation	see 6	
Mass	Approx 9,00/10,2 kg	

### 4 PRESSURE DROP

$\Delta p$ -Q  
Measured at  $v = 166$  SUS (35 mm<sup>2</sup>/s) and  $t = 122$  °F (50 °C)

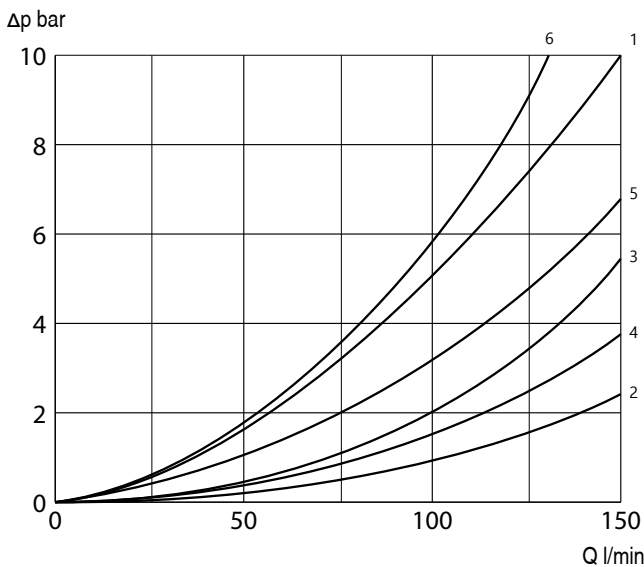

### 5 SPOOL IDENTIFICATION AND INTERMEDIATE POSITION TRANSITORIES

Three positions with spring centering

1C		
0C		
3C		
4C		

Two positions with return spring

1LL		
0LL		
1ML		
1LLb		
0LLb		
1MLb		

Three positions with spring centering - special spools

77C		
56C		
8C		
76C		

**6** INSTALLATION DIMENSIONS (mm)

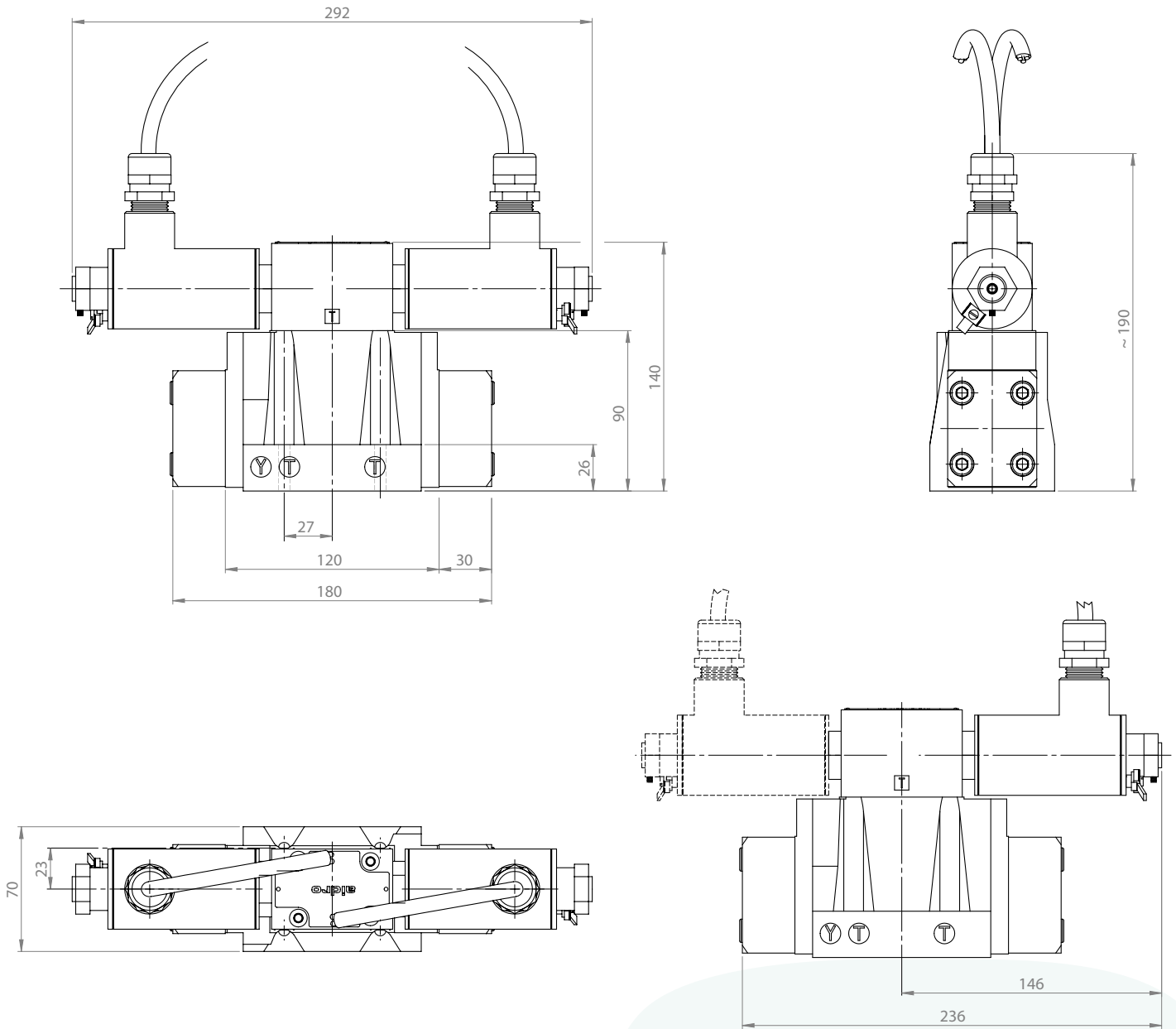



Spool type	Spool position	Connections				
		P-A	P-B	A-T	B-T	P-T
		Curves on graph				
1C	Energized	1	1	2	3	
0C	De-energized					6*
	Energized	5	5	1	2	
3C	De-energized			4*	4°	
	Energized	1	1	1	2	
4C	De-energized					6
	Energized	6	6	3	4	
1LL,0LL	De-energized	1			3	
1ML	Energized		1	2		
77C	De-energized				4	
	Energized	1	1	2	2	
56C	De-energized					6*
	Energized	6	6	4	3	
8C	De-energized	4*	4°			
	Energized	5	5	2	3	
76C	De-energized			3		
	Energized	1	1	1	3	

\* A-B blocked  
 · B blocked  
 ° A blocked

### Control of the main spool stroke: C

It is possible to introduce special stroke controls in the heads of the hydropiloted valve so as to vary the maximum spool stroke. This solution allows control of the flow rate from the pump to the actuator and from the actuator to the outlet, obtaining a double adjustable control on the actuator. Add the letter **C** to the identification code to request this device.

### Control of the main spool shifting speed: D

By placing a double flow control valve between the pilot solenoid valve and the hydropiloted valve, the piloted flow rate can be controlled and therefore the shifting speed can be varied. Add the letter **D** to the identification code to request this device.

### Control of the main spool stroke and shifting speed: G

It is possible to have the valve fitted with both the spool stroke device and the piloting flow rate control device. Add the letter **G** to the identification code to request this solution.





# SUMMARY



## PROPORTIONAL VALVE

PROPORTIONAL 4-WAY CONTROL VALVES SOLENOID OPERATED  
**HD3-PS-\***

0001

PROPORTIONAL 4-WAY CONTROL VALVES SOLENOID OPERATED  
**HD5-PS-\***

0004

PILOT OPERATED PRESSURE RELIEF VALVE  
**PMO-78/\***

0007

DIRECT OPERATED PRESSURE REDUCING VALVE  
**PRO-M24.\***

0009

UNIVERSAL ELECTRONIC DRIVER  
**UED-\***

0011

UNIVERSAL ELECTRONIC DRIVER  
**UED-KA**

0015

**aidro**  
hydraulics



## PROPORTIONAL 4-WAY CONTROL VALVES SOLENOID OPERATED

### HD3-PS-\*

32 l/min 32 MPa (320 bar)

#### 1 DESCRIPTION

Valves HD3-PS are proportional directional control valve with subplate mounting interface acc. to ISO 4401, DIN 24340 (CETOP 03).

The design of the body is an high quality five chamber casting. The valve is available with different spools able to control different flow ranges. In the standard version, the valve housing is phosphated for 240 h salt spray protection acc. to ISO 9227.

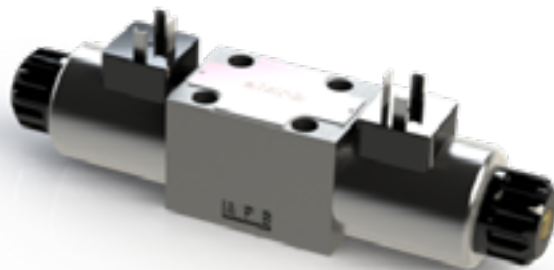

#### 2 ORDERING CODE

(1)	(2)	(3)	(4)	(5)	(6)
HD3	-	PS	-	-	/ 10

(1) 4-way directional valve CETOP 03 – Pressure 32 MPa (320 bar)

(2) PS : Proportional electric control

(3) Functional spool type (see 4):

-number is the main spool type

1: closed center (P, A, B, T blocked)

3: P blocked, A, B, T connected

-spool nominal flow

P : 32 l/min with P = 1 MPa (10 bar) (PA+BT or PB+AT)

R : 16 l/min with P = 1 MPa (10 bar) (PA+BT or PB+AT)

05 : 05 l/min with P = 1 MPa (10 bar) (PA+BT or PB+AT)

D : differential  $Q_b = 2Q_a$ : 32/16 l/min with P = 1 MPa (10 bar)

-letter is the solenoid or spring arrangement:

C : 2 solenoids, spool is springs centred

ML : 1 solenoid ("a") spool is centred + 1 end position

MLb : 1 solenoid ("b") spool is centred + 1 end position

(4) Options and variants:

K : extended manual overrides (see 7)

AK : extended manual overrides with air bleeding valves (see 8)

ZC : zinc plated valves (see 9)

(5) Type of coil and supply voltages

R2 : R= 2,3 standard for V12DC; R3 : R= 4,5

R4 : R=13,4 standard for V24DC; R5 : R=18,6

(6) Design number (progressive) of the valve.

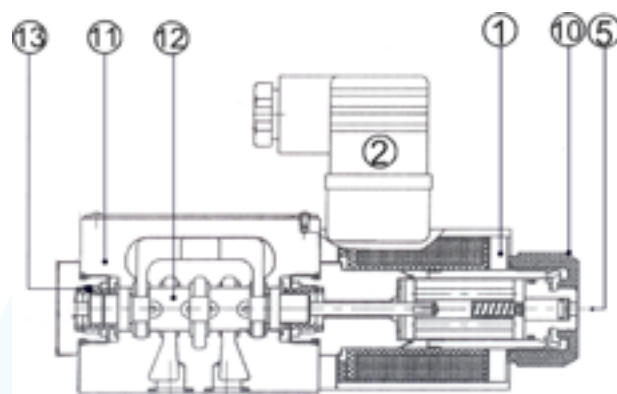
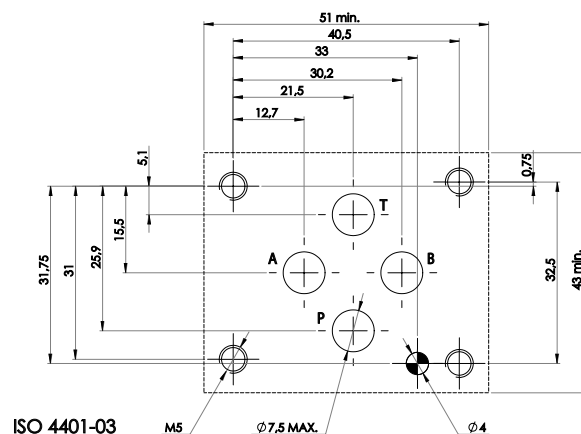

The spool 12 shifts in to the valves body 11 subject to the action of springs 13 and proportional solenoid 1. Spool 12, depending from its shape and its position in the valves body 11, opens and/or closes passages between P, A, B, T ports, thus controlling the direction and the rate of the hydraulic flow. Solenoid 1 is energized by electric current flowing-in through cables; in case of electric cut-offs, the spool can be manually shifted by acting on the emergency pins 5, located at the end of the solenoids and accessible through the retaining nuts 10.

### 3 TECHNICAL DATA

Nominal flow rates	5, 16, 32 l/min	<b>Electric Characteristics:</b> Valves type HD3-PS-* are operated by proportional solenoids that are rated for an average max power of 13,5 w. The values of nominal max. current are: for coils type R2 ( 2,3 Ω): I max = 2,4 A R3 ( 4,5 Ω): I max = 1,7 A R4 (13,4 Ω): I max = 1,0 A R5 (18,6 Ω): I max = 0,85 A  Currents to hydraulic proportional valves are normally supplied by an electronic driver based on PWM mode of operation, capable of full control of min and max values of current for drivers type UED-*
Maximum nominal pressure (P,A,B)	32 MPa (320 bar)	
Maximum pressure at T port	16 MPa (160 bar)	
Maximum rec. Pressure drops	10 MPa (100 bar) see [8]	
Protection DIN 40050	IP 67	
Duty cycle	100%	
Service life	≥ 10 <sup>7</sup> cycles	
Installation and Dimensions	(see [10])	
Mass	Approx 1,6 / 2,1 kg.	

### 4 SPOOL IDENTIFICATION AND NOMINAL FLOW RATE

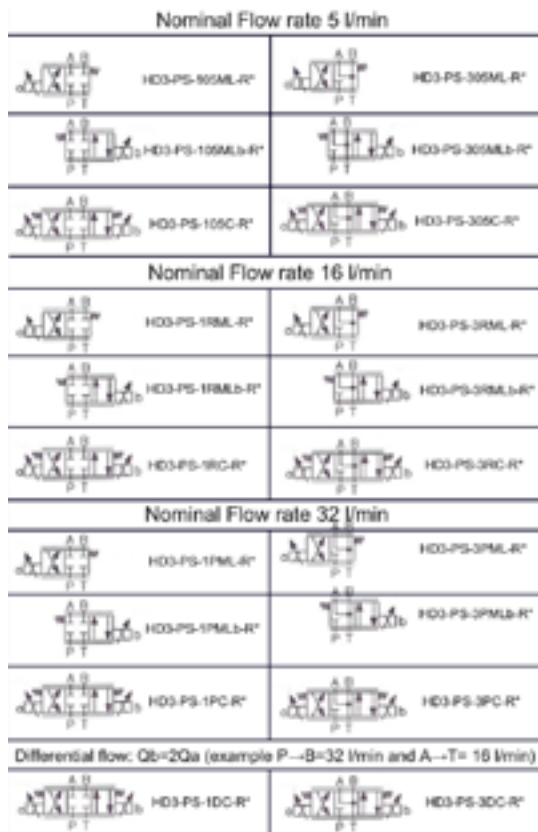

### 5 TYPICAL DIAGRAMS

Typical flow curves of valves HD3-PS-\*, with spools type P, R, 05, in standard configuration measured with mineral oil at 36 cSt and at 50°C at ΔP=01 MPa (10 bar) for flow P->B A -> T

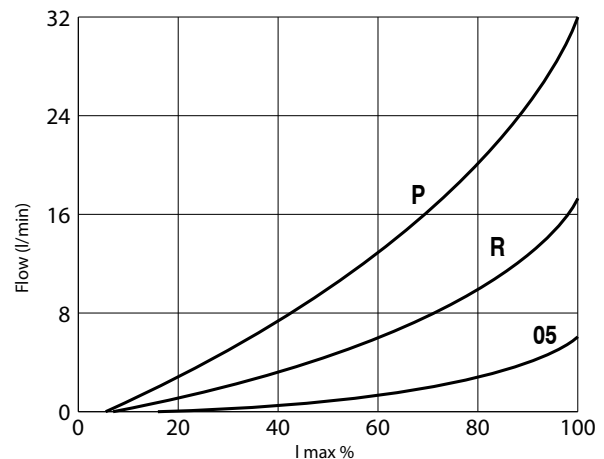

### 6 FLOW RATES AND PRESSURE DIFFERENTIAL

For a given ΔP on a given valve the flow rates are proportional to the driving current; for a given driving current on a given valve, the flow rates increase with the increasing of the ΔP up to certain limits. Typical limit curves are:

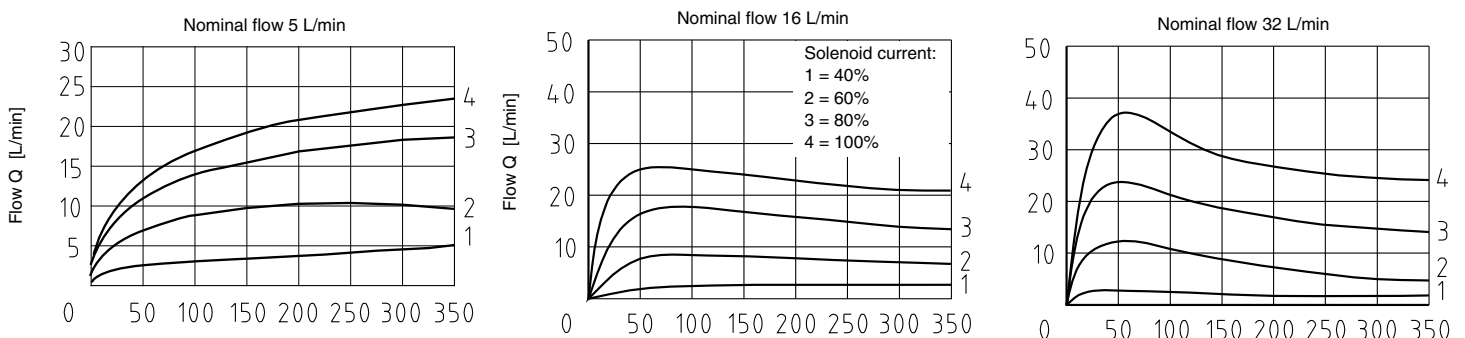

## 7 VERSION "K": EXTENDED EMERGENCY PIN

Solenoid valves according to "K" version have extended emergency actuator pins protruding from the solenoid shape, that permit a quick and easy "Hand operation" of the valves, without the need of any tool. The actuator pin and the end of the solenoid are protected by a flexible rubber cap that makes easy operation and protects from moisture and water splashes.

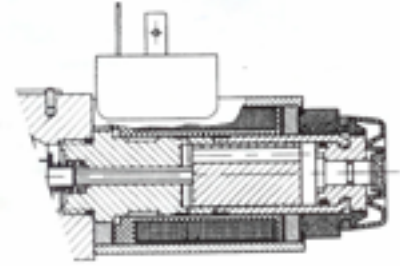

## 8 VERSION "AK": EXTENDED PIN AND AIR VALVES

Proportional valves according to "AK" version have extended emergency actuator pins that incorporate air bleeding valves, to purge air from the solenoid tube for a simplified start-up of the system. The actuator pin and the end of the solenoid are protected by a flexible rubber cap that makes easy operation and protects from moisture and water splashes.

## 9 VERSION "ZC": ZINC PLATED VALVES

Solenoid valves according to "ZC" version have central body zinc plated and protected against every type of corrosion due to saline ambiance or other aggressive chemicals. Zinc thickness are on the valve body: 10-15  $\mu$ m; and 8/12  $\mu$ m on solenoids.

## 10 INSTALLATION DIMENSIONS (mm)

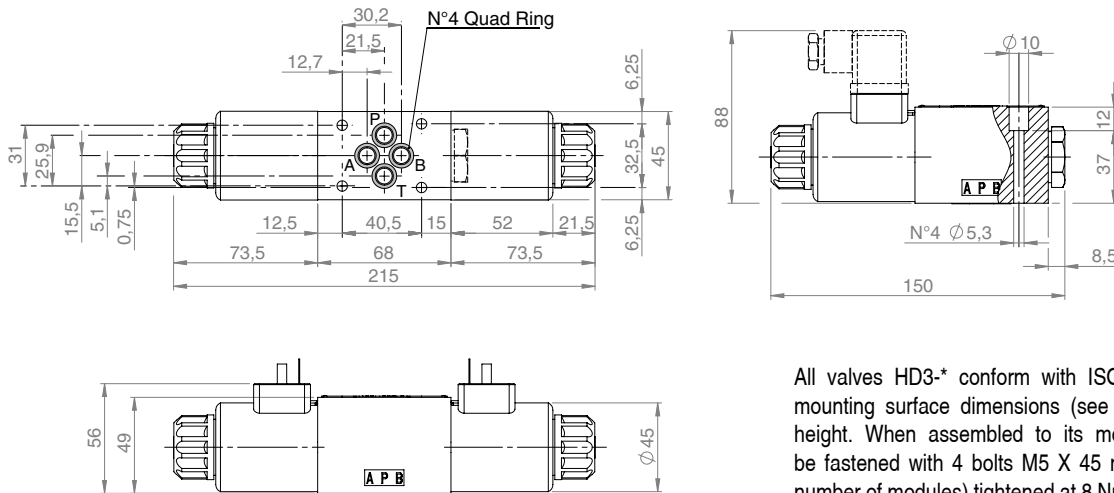

All valves HD3-\* conform with ISO and CETOP specifications for mounting surface dimensions (see also front page) and for valves height. When assembled to its mounting plate valve HD3-\* must be fastened with 4 bolts M5 X 45 mm (or M5 x \*\* according to the number of modules) tightened at 8 Nm torque. Of special interest is the mounting of pressure compensator modules with HD3-P proportional valves. Leakage between valve and mounting surface is prevented by the positive compression on their seats of 4 seals of QUAD/O Ring type 9,25x1,68x1,68.

## 11 HYDRAULIC FLUIDS

Seals and materials used on standard valves HD3-\* are fully compatible with hydraulic fluids of mineral oil base, upgraded with antifoaming and anti-oxidizing agents. The hydraulic fluid must be kept clean and filtered to ISO 4406 class 19/17/14, or better, and used in a recommended viscosity range from 10 cSt to 60 cSt.

## 12 PRESSURE COMPENSATOR MODULES.

2-way pressure compensator for meter-in application type AM3-PCP – see table AM-391. When using the 2-way pressure compensators in meter-in application, shown in the circuit diagram, a constant pressure difference across the metering edge of the proportional directional valve is held. In this case, the pressure variations due to loading changes, as well as pump pressure changes, are compensated. That means that a pressure change cannot result in flow increase. 3-way pressure compensator type AM3-LS-P is able to operate as "load sensing" device, by ischarging at T port, at the same pressure of the user, the flow that exceeds the flow rates required by the controlled opening of the proportional 4-way valve.

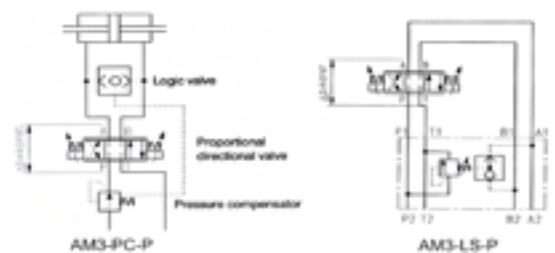

**PROPORTIONAL 4-WAY CONTROL VALVES SOLENOID OPERATED**

**HD5-PS-\***

**63 l/min 32 MPa (320 bar)**

**1 DESCRIPTION**

Valves HD5-PS are proportional directional control valve with subplate mounting interface acc. to ISO 4401, DIN 24340 (CETOP 05). The design of the body is an high quality five chamber casting. The valve is available with different spools able to control different flow ranges. In the standard version, the valve housing is phosphated for 240 h salt spray protection acc. to ISO 9227.

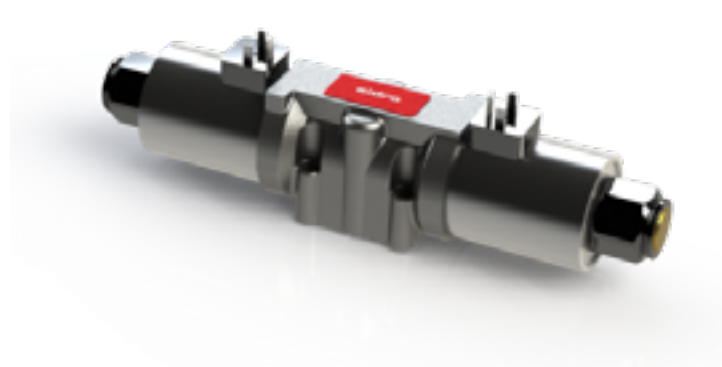

**2 ORDERING CODE**

(1)	(2)	(3)	(4)	(5)	(6)
HD5	-	PS	-	-	/ 10

(1) HD5 : 4-way directional valve CETOP 05 – Pressure 32 MPa (320 bar)

(2) PS : Proportional electric control

(3) Functional spool type (see 4)

-number is the main spool type

1: closed center (P, A, B, T blocked)

3: P blocked, A, B, T connected

-spool nominal flow

P: 63 l/min with  $\Delta P = 1$  MPa (10 bar) (PA+BT or PB+AT)

R: 32 l/min with  $\Delta P = 1$  MPa (10 bar) (PA+BT or PB+AT)

D: differential  $Q_b = 2Q_a$ : 63/32 l/min with  $P = 1$  MPa (10 bar)

-solenoid and springs arrangements

C : 2 solenoid, spool is springs centred

ML : 1 solenoid ("a") spool is centred + 1 end position

MLb : 1 solenoid ("b") spool is centred + 1 end position

(4) Options and variants:

K : extended manual overrides(see 7)

AK : extended manual overrides with air bleeding valves (see 8)

ZC : zinc plated valves (see 9)

(5) Type of coils and supply voltages

R1 : R= 3,78  $\Omega$

R2 : R= 4,7  $\Omega$  standard for V12DC;

R4 : R=13,9  $\Omega$  standard for V24DC;

(6) Design number (progressive) of the valve.

ISO 4401-05-04-0-05  
(CETOP 4.2-4-05-320)

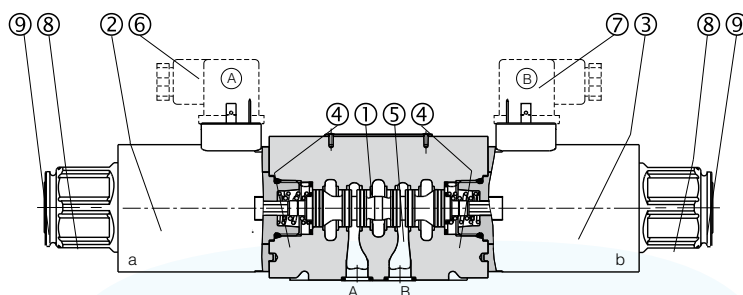
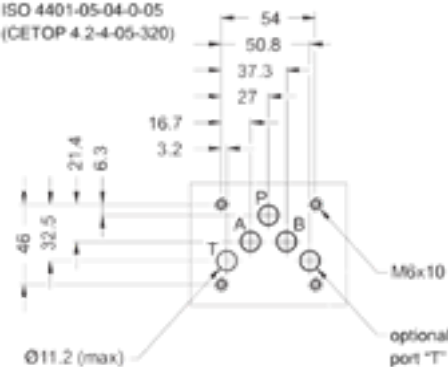

The spool 1 shifts in to the valves body 5 subject to the action of springs 4 and proportional solenoid 2 and 3. Spool 1, depending from its shape and its position in the valves body, opens and/or closes passages between P, A, B, T ports, thus controlling the direction and the rate of the hydraulic flow. Solenoid 2 and 3 is energized by electric current flowing-in through cables; in case of electric cut-offs, the spool can be manually shifted by acting on the emergency pins, located at the end of the solenoids and accessible through the retaining nuts.

### 3 TECHNICAL DATA

Nominal flow rates	32, 63 l/min	<b>Electric Characteristics:</b> Valves type HD5-PS-* are operated by proportional solenoids that are rated for an average max power of 13,5 W. The values of nominal max. current are: for coils type R1 ( 3,78 Ω): I max = 2,4 A R2 ( 4,7 Ω): I max = 1,9 A R4 (13,9 Ω): I max = 1,1 A Currents to hydraulic proportional valves are normally supplied by an electronic driver based on PWM mode of operation, capable of full control of min and max values of current for drivers type UED-*
Maximum nominal pressure (P,A,B)	32 MPa (320 bar)	
Maximum pressure at T port	21 MPa (210 bar)	
Maximum rec. Pressure drops	10 MPa (100 bar) (see 6)	
Protection DIN 40050	IP 67	
Duty cycle	100%	
Service life	≥ 10 <sup>7</sup> cycles	
Installation and Dimensions	(see 10)	
Mass	Approx 4,3 / 5,8 kg.	

### 4 SPOOL IDENTIFICATION AND NOMINAL FLOW RATE

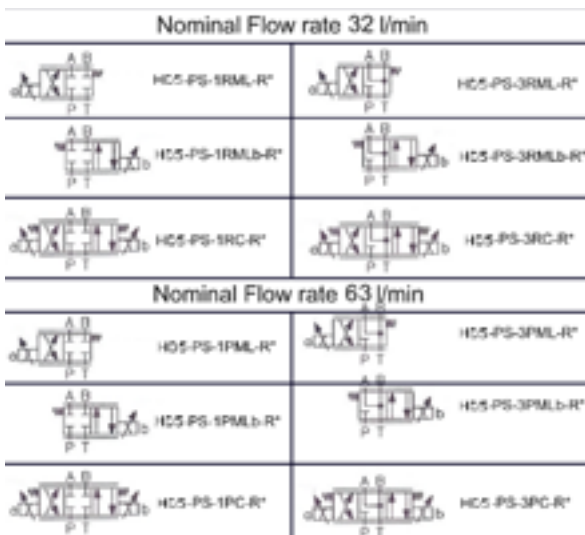

### 5 TYPICAL DIAGRAMS

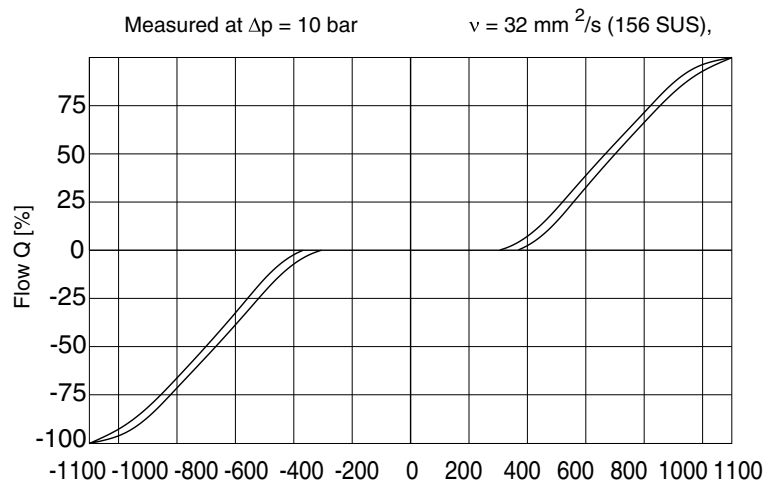

### 6 FLOW RATES AND PRESSURE DIFFERENTIAL

For a given  $\Delta P$  on a given valve the flow rates are proportional to the driving current; for a given driving current on a given valve, the flow rates increase with the increasing of the  $\Delta P$  up to certain limits. Typical limit curves are:

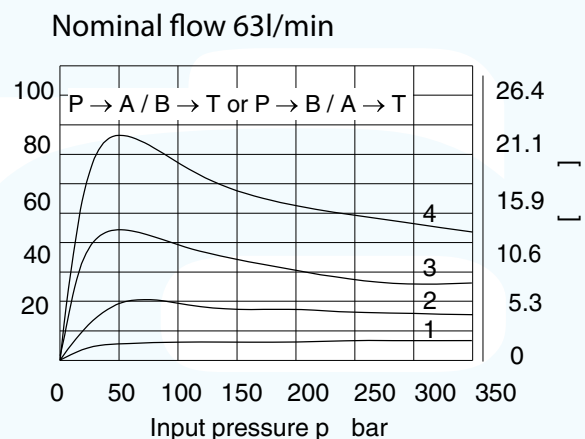
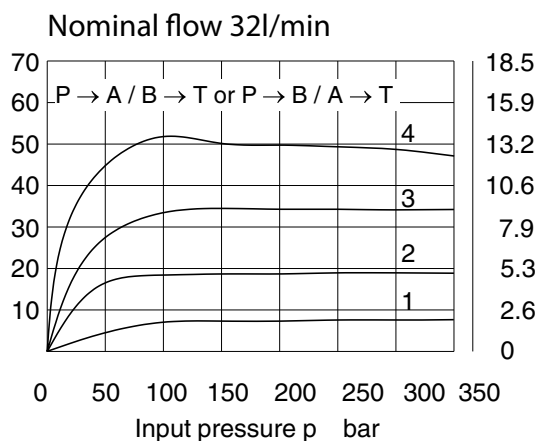

## 7 VERSION "K": EXTENDED EMERGENCY PIN

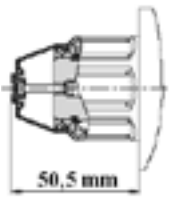

Solenoid valves according to "K" version have extended emergency actuator pins protruding from the solenoid shape, that permit a quick and easy "Hand operation" of the valves, without the need of any tool. The actuator pin and the end of the solenoid are protected by a flexible rubber cap that makes easy operation and protects from moisture and water splashes.

## 8 VERSION "AK": EXTENDED PIN AND VALVE AIR BLEEDING

Proportional valves according to "AK" version have extended emergency actuator pins that incorporate air bleeding valves, to purge air from the solenoid tube for a simplified start-up of the system. The actuator pin and the end of the solenoid are protected by a flexible rubber cap that makes easy operation and protects from moisture and water splashes.

## 9 VERSION "ZC": ZINC PLATED VALVES

Solenoid valves according to "ZC" version have central body zinc plated and protected against every type of corrosion due to saline ambiance or other aggressive chemicals. Zinc thickness are on the valve body: 10-15 µm; and 8/12 µm on solenoids.

## 10 INSTALLATION DIMENSIONS (mm)

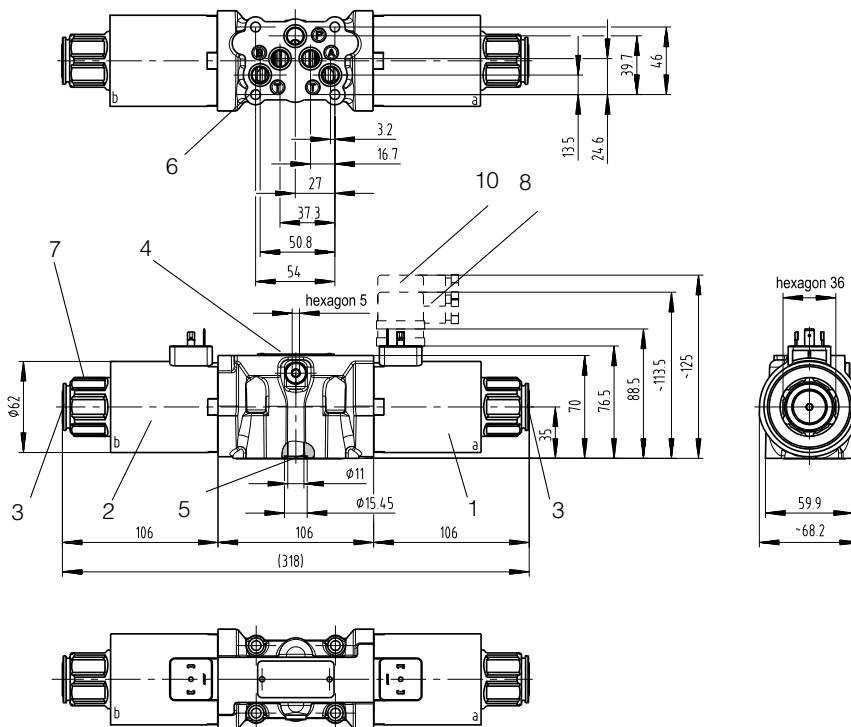

All valves HD5-PS-\* conform with ISO and CETOP specifications for mounting surface dimensions (see also front page) and for valves height. When assembled to its mounting plate, valve HD5-ES-\* must be fastened with 4 fixing bolts (socket head screws to ISO 4762) M6 x 40 mm (or M6 x \* according to the number of modules) of class 12,9 (ISO898) tightened at 12 Nm torque. Leakage between valve and mounting surface is prevented by the positive compression on their seats of 5 seals of Quad-Ring type 12,42 x 1,68 x 1,68 mm.

## 11 HYDRAULIC FLUIDS

Seals and materials used on standard valves HD5-\* are fully compatible with hydraulic fluids of mineral oil base, upgraded with antifoaming and anti-oxidizing agents. The hydraulic fluid must be kept clean and filtered to ISO 4406 class 19/17/14, or better, and used in a recommended viscosity range from 10 cSt to 60 cSt.

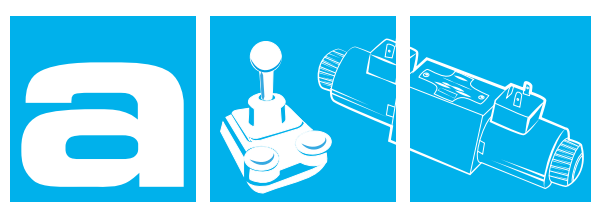

## PILOT OPERATED PRESSURE RELIEF VALVE

### PMO-78/\*

60 l/min 35 MPa (350 bar)

#### 1 DESCRIPTION

Proportional pressure relief valve in cavity 7/8" 14 UNF.

The valve is available in two configurations: standard, where with no current there is no pressure in the system, and positive where with no current you have the desired pressure in the system.

Valves are normally supplied with coils with integrated quenching diode in order to protect the electronics connected with the valve.

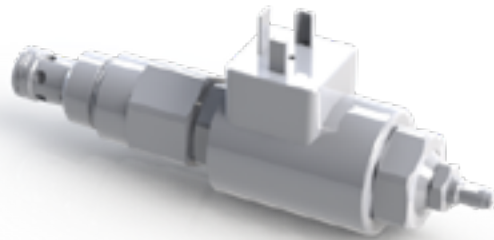

#### 2 ORDERING CODE

(1)	(2)	(3)	(4)	(5)	(6)
PMO	-	78	/	-	

(1) PMO : Proportional pressure relief valve

(2) Function:

no designation : Standard (relief 0 bar with 0 current)  
 P: Positive (relief 180 bar with 0 current)

(3) 78: cavity SAE10 (7/8" 14 UNF)

(4) Pressure range:

12: up to 120 bar (1740 PSI)  
 21: up to 210 bar (3046 PSI)  
 35: up to 350 bar (5076 PSI)

(5) Electric voltage and solenoid coils

012C: coil(s) for V12DC with quenching diode  
 024C: coil(s) for V24DC with quenching diode

(6) Coil connection

no designation : DIN 43650-A ISO 4400  
 AMP: Amp Junior Timer  
 D: Deutsch DT04-2P

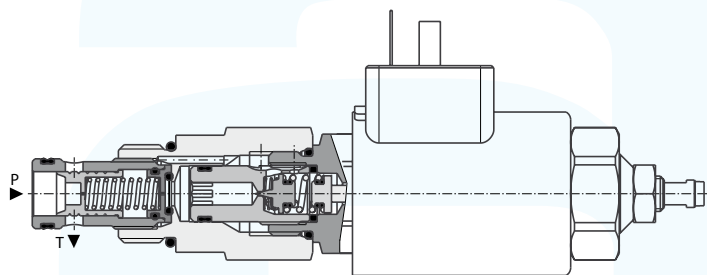
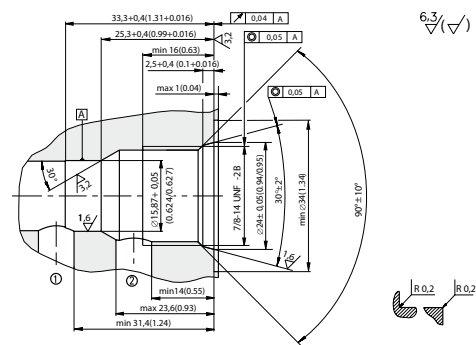
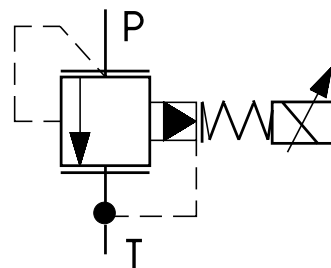

The valve is designed for continuous regulation of pressure in the circuit. It is pilot operated from a pilot stage. The increase/decrease of the pressure P in the system is proportional to the energizing current at solenoid. For a self bleeding of the valve it is recommended to install the valve in vertical position with coil on the bottom. If it is not possible, it is necessary to act on the bleeding screw in order to assure a proper function of the valve.



## 3 TECHNICAL DATA

Nominal flow	50 l/min	Electric characters:
Maximum rec. flow rate	50 l/min	Valve type PMO*.78 are operated by solenoid that are energized from a D.C. voltage supply:
Maximum nominal pressure	35 MPa (350 bar)	V 12 DC = 012C
Optimal dither control	250 Hz	V 24 DC = 024C
Valve Hysteresis	<5 %	With an appropriate electrical driver in order to control the input current at the valve
Protection	IP 67	Coils have an integrated quenching diode and their characteristics are:
Duty cycle	100%	V 12 DC - limit current 1,0 A - 6,5 Ohm
Installation and dimension	(see [5])	V 24 DC - limit current 0,6 A - 20,8 Ohm
Valve Body	Steel	
Mass	0,58 kg	
Note: pressure in T line influences valve performances		

## 4 TYPICAL DIAGRAMS

Typical P-Q curves for valves PMO\*.78 in standard configuration, with mineral oil at  $v=32 \text{ mm}^2/\text{s}$  and at  $T=40^\circ\text{C}$ .

### p-I Chart

Measured at  $v = 32 \text{ mm}^2/\text{s}$  (156 SUS)

$p = f(I)$ ,  $Q = 5 \text{ L/min}$  (1.321 GPM)

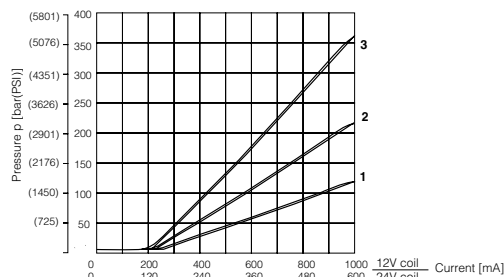

3	Pressure range 35
2	Pressure range 21
1	Pressure range 12

#### Attention:

The proportional pressure relief valve is not mechanically protected and it does not perform the relief valve function.

### p-Q Chart

Measured at  $v = 32 \text{ mm}^2/\text{s}$  (156 SUS)

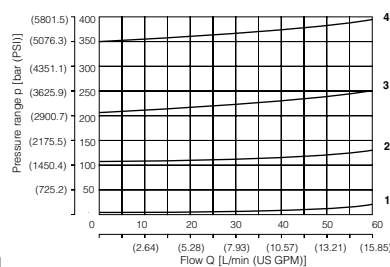

4	Pressure range 35
3	Pressure range 21
2	Pressure range 12
1	Min. pressure (range 35)

### PMOP.78 pressure setting

p-I Characteristics

Valve performance flow 5 dm<sup>3</sup>/min, direction P-T

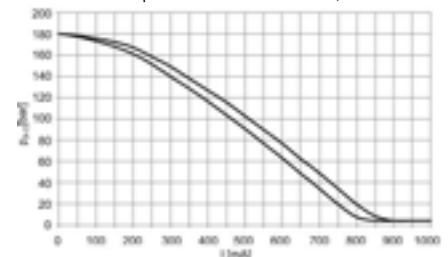

## 5 INSTALLATION DIMENSIONS (mm)

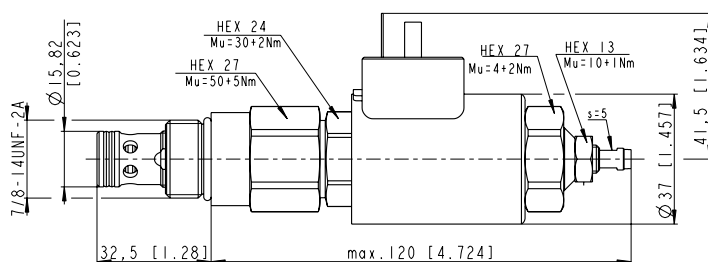

## 6 HYDRAULIC FLUIDS

Seals and materials used on standard valves PMO\*.78 are fully compatible with hydraulics fluids of mineral base, upgraded with antifoaming and anti oxidizing agents. The hydraulic fluid must be kept clean and filtered to ISO 4406 class 19/17/14, or better, and used in a recommended viscosity range from 10 cSt to 60 cSt.

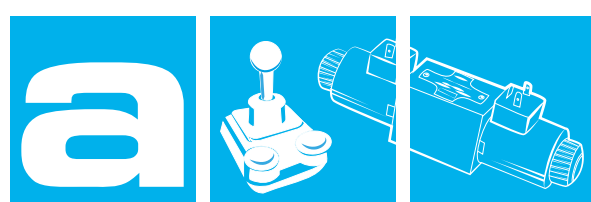

## DIRECT OPERATED PRESSURE REDUCING VALVE PRO-M24.\* 40 l/min 9 MPa (90 bar)

### 1 DESCRIPTION

Proportional pressure reducing valve direct operated in cavity M24 x 1,5. The valve is available in different pressure ranges and his robust design permits a stable and reliable functioning. Valves are normally supplied with coils with integrated quenching diode in order to protect the electronics connected with the valve.



### 2 ORDERING CODE

(1)	(2)	(3)	(4)	(5)
PMO	-	M24	/	-

(1) PRO:Proportional pressure reducing valve direct operated

(2) M24:metric cavity M24x1,5 (see drawing)

(3) Max. reducing pressure

- 18 bar
- 20 bar
- 30 bar
- 80 bar

(4) Electric voltage and solenoid coils

- 012C: coil(s) for V12DC with quenching diode
- 024C: coil(s) for V24DC with quenching diode

(5) Coil connection:

- AMP: Amp Junior Timer
- D: Deutsch DT04-2P

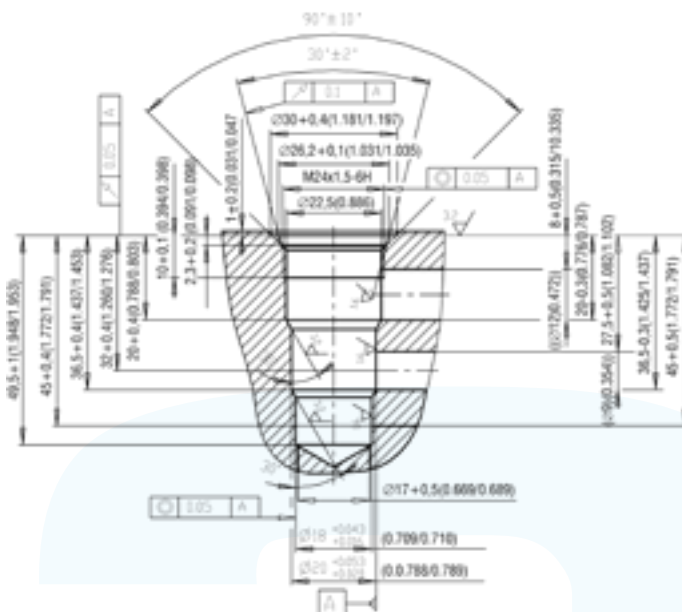
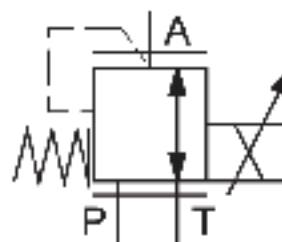

The valve is designed for continuous regulation of pressure in the circuit. It is direct operated. The increase/decrease of the pressure P in the system is proportional to the energizing current at solenoid. The reduced pressure is defined by coil current as shown on the static pressure characteristic.

## 3 TECHNICAL DATA

Nominal flow	40 l/min	Electric characters:
Maximum nominal pressure	9 MPa (90 bar)	Valve type PRO-M24 are operated by solenoid that are energized from a D.C. voltage supply V 12 DC = 012C V 24 DC = 024C
Optimal PWM freq.	150 Hz	with an appropriate electrical driver in order to control the input current at the valve
Protection	IP 67 or IP69K (Deutsch)	Coils have an integrated quenching diode and their characteristics are: V 12 DC - limit current 1,5 A - 5,0 Ohm V 24 DC - limit current 1,0 A - 13,4 Ohm
Duty cycle	100%	
Installation and dimension	(see 5)	
Valve Body	Steel	
Mass	0,4 kg	

## 4 TYPICAL DIAGRAMS

Reduced pressure related to control signal

Port A, range 0 - 20 bar (290 PSI), Q = 0 lpm (GPM)  
Port P, inlet pressure 50 bar (730 PSI)

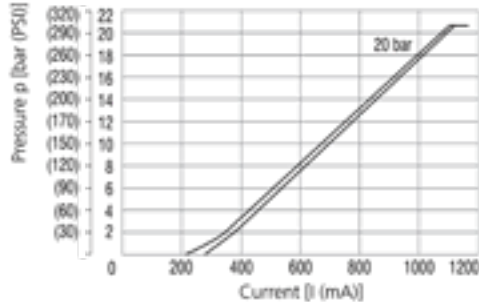

Reduced pressure related to control signal

Port A, range 0 - 80 bar (1160 PSI), Q = 0 lpm (GPM)  
Port P, inlet pressure 90 bar (1305 PSI)

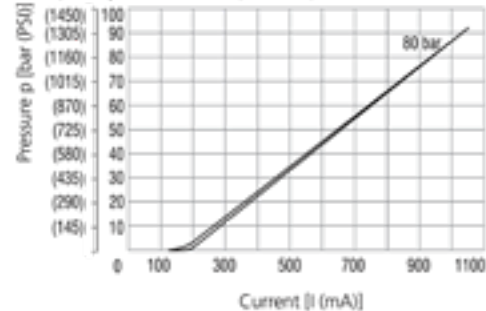

Reduced pressure related to control signal

Port A, range 0 - 18 bar (260 PSI), Q = 0 lpm (GPM)  
Port P, inlet pressure 50 bar (730 PSI)

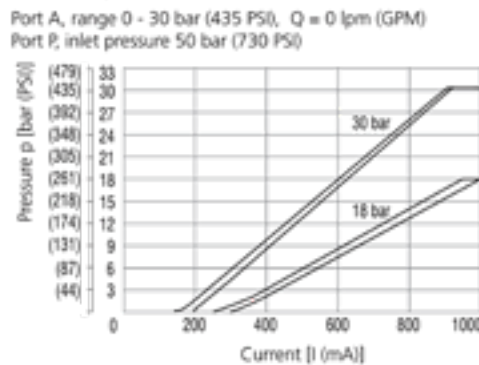

Pressure drop related to flow rate

A-T, Valve coil de-energized (relieving function)  
P-A, Valve coil energized (reducing function)

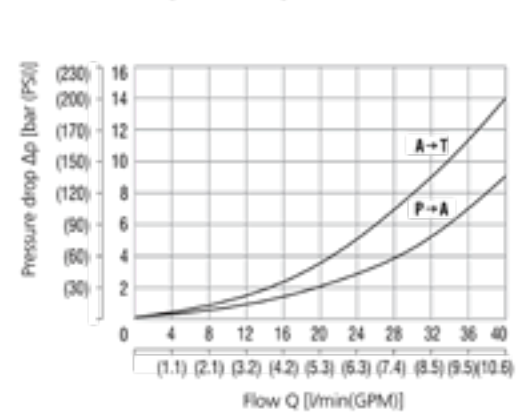

## 5 INSTALLATION DIMENSIONS (mm)

ANP Junior Timer - IP67

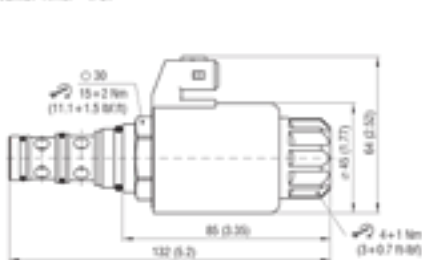

Deutsch DT04-2P - IP69K

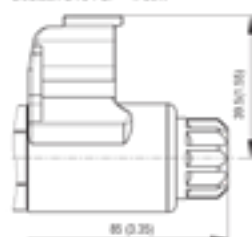

## 6 HYDRAULIC FLUIDS

Seals and materials used on standard valves PRO-78 are fully compatible with hydraulics fluids of mineral base, upgraded with antifoaming and anti oxidizing agents. The hydraulic fluid must be kept clean and filtered to ISO 4406 class 19/17/14, or better, and used in a recommended viscosity range from 10 cSt to 60 cSt.

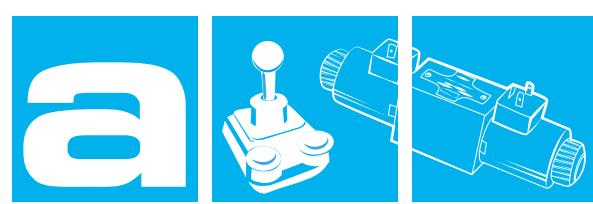

## UNIVERSAL ELECTRONIC DRIVER UED-\* for solenoid operated proportional valves

### 1 DESCRIPTION

The driver controls one or two solenoids of a proportional valve. His construction permits an easy assembly directly on the DIN rail of the electric cabinet. By the use of two selectors it is possible to easily configure all the parameters without the need of special tools or programming devices.

A 4 digit led display shows all the necessary informations.

- Microcontroller design
- Independent adjustments (ramp up - ramp down)
- 4 digit led display
- Display and adjust actual values (current&voltage)
- Easy access to the menu setup
- Wide ramp time range
- Simple control with analog input, locally supplied reference voltage
- No heat sink required
- Electronic limiting circuit/short circuit proof
- Reverse polarity, command input protection
- Load can be connected and disconnected live

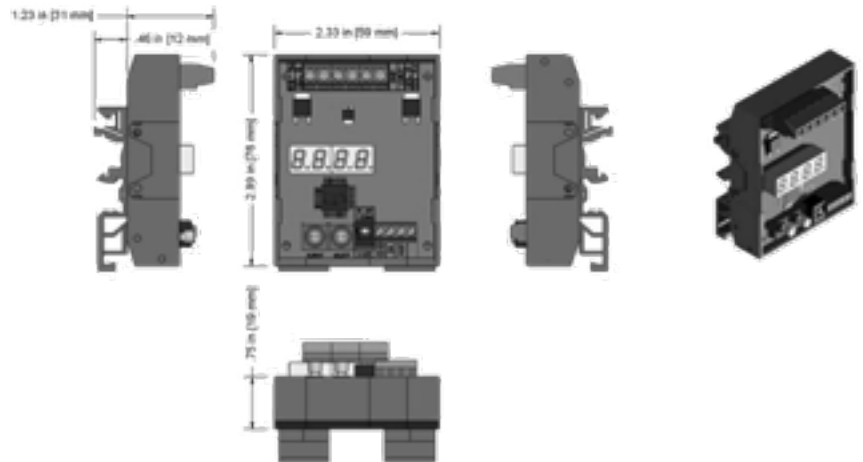

### 2 ORDERING CODE

(1)	(2)
UED	-

(1) UED: Universal Electric Driver for Proportional valves

(2) Configuration:

- S: for single solenoid proportional valves
- D: for double solenoid proportional valves

### 3 SET UP PROCEDURE

Available input selection UED-S	Available input selection UED-D
	DIP Switch in ON/UP position
"in" :10 -->(0 to 10V) ** default	"in" :10 -->(0 to 10V) ** default
"in" :5 --> (0 to 5V)	"in" :5 --> (0 to 5V)
"in" :420 --> ( 4 to 20 mA)	"in" :420 --> ( 4 to 20 mA)
	DIP Switch in OFF/Down position
	"in" : -10 -->(-10 to 10V)

(1) At power up, the display will show either the output current signal or the input signal (Default display setting shows the output signal).  
The decimal point will be flashing.

(2) Rotate SELECT to enter the set-up mode. Parameter abbreviation is indicated on the display

(3) When you reach the setting you want to modify, rotate ADJUST up or down to the desired value.

(4) To modify another setting, rotate SELECT again and repeat.

(5) The Driver is fully functional during the set-up procedure with any adjustments effective immediately.

(6) In order to write the new settings in the memory and return to normal mode of operation, rotate „SELECT“ until the display shows „SR“ and then rotate „ADJUST“ from 0 to 1 or wait for 100 seconds.

(7) If you do not want to save the new settings you have just modified, you must disconnect the Driver from the power supply before the end of the 100 seconds to restore precious settings.

(8) After saving parameters to memory, the decimal point will be flashing and the Driver display will be back showing either the output current signal or input signal depending on your „di“ selection.

(9) To start over completely, you can restore the factory settings by rotating SELECT to rFP and then rotate ADJUST up past 10 for the display to reset (NOTE for Step 9: you may have to adjust your Input Signal Setting again if you reset to factory settings.)

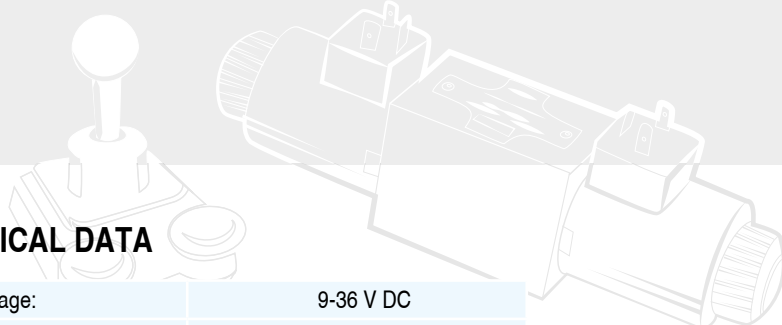

#### 4 TECHNICAL DATA

Operating voltage:	9-36 V DC
Maximum output current:	3,00 A
Input signal:	0-5 V; 0-10V; 4-20 mA
Maximum ramp time:	99,5 s
Linearity:	40-450 Hz
Operating Temperature:	-40 .. 80 °C
Mounting:	DIN rail (open)

#### 5 SETTING RANGES

Parameter	Description	Adjustable Range
Hi *	HIGH, Maximum Current Output	0,20 - 3,00 A
Lo *	LOW, Minimum Current Output (see note 1)	0,00 - 2,99 A
rUP *	RAMP UP, Time for Output to increase from min to max	0,0 - 99,5 s
rdn *	RAMP DOWN, Time for Output to decrease from max to min	0,0 - 99,5 s
Cdb	COMMAND DEADBAND, Output disabled if command signal is less then deadband	0 - 5 %
JC	JOYSTICK CALIBRATION / INPUT OFFSET COMPENSATION, midpoint between a and b at 50%	40 - 50 - 60%
dFr	DITHER FREQUENCY	40 - 450 Hz
in	INPUT SIGNAL SELECTION: 5 - Voltage signal 20 - Voltage signal 420 - Current signal	0 - 5 V 0 - 10 V 4 - 20 mA
di	DISPLAYED SIGNAL FOR TROUBLESHOOTING: 0 - Command signal [V] or [mA] 1 - Output signal [A] **Flashing decimal point is an indicator for present display mode** - Fast flashing decimal point, several flashes per second indicates di=0 - Slow flashing decimal point, 1 per second indicates di=1 - No flashing decimal point or no decimal point indicates display in SETTING/ADJUST	
SA	SAVE SETTINGS	
rFP	RESET FACTORY PARAMETERS (see note 2)	
Err	ERROR DETECTION STATE, short circuit, reverse polarity protection and detection: 0 - Error 0 - No errors 1 - Error 1 - Overcurrent in driver likely due to short circuit in Solenoid 2 - Error 2 - Current exceeding 20 mA in 4-20 mA input mode	
CLr	CLEAR ERROR, clear driver or error state (see note 2)	
NOTE 1	When adjusting the HI and LO parameters, note the HI parameter value cannot be adjusted below the LO parameter value as well the LO parameter value cannot exceed the HI parameter value.	
NOTE 2	Adjust Parameter value up past 9 to operate this command setting	
NOTE 3	* in UED-D parameter will be aHi or bHi (as example) when a solenoid or b solenoid is configured	

## 6 SCHEMATIC UED-S

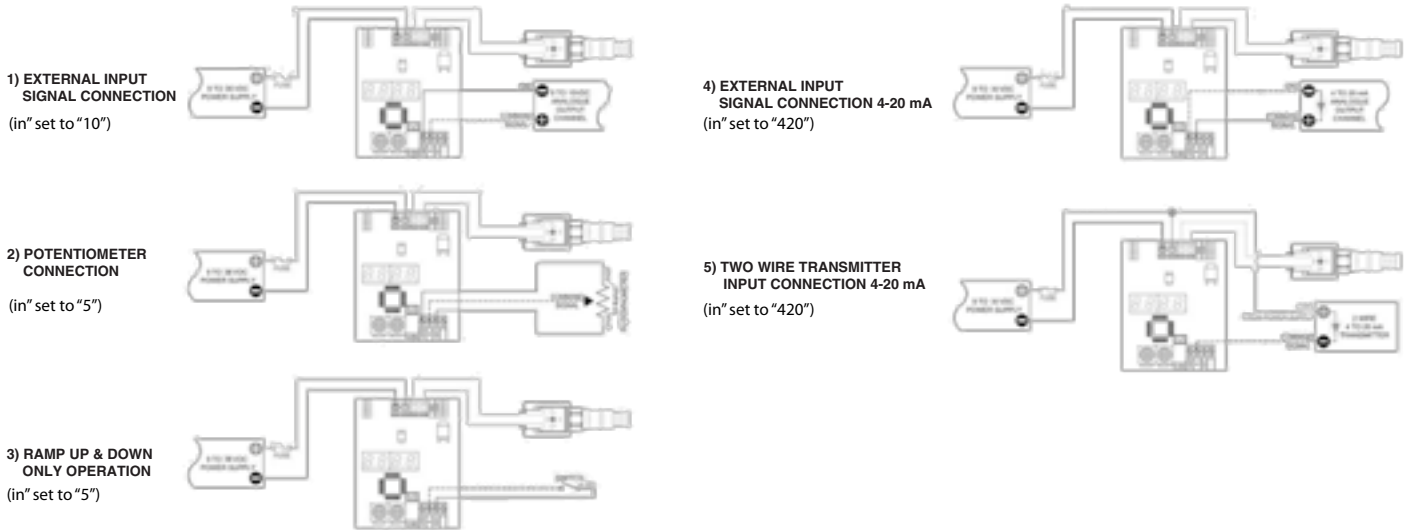

Note: for "0 to 5 VDC" and "0 to 10 VDC" command input drivers, it is recommended to use independent negative conductors for power supply and analogue output channel (PLC/PC) to maintain command signal accuracy due to voltage drop on long cable runs.

## 7 SCHEMATIC UED-D

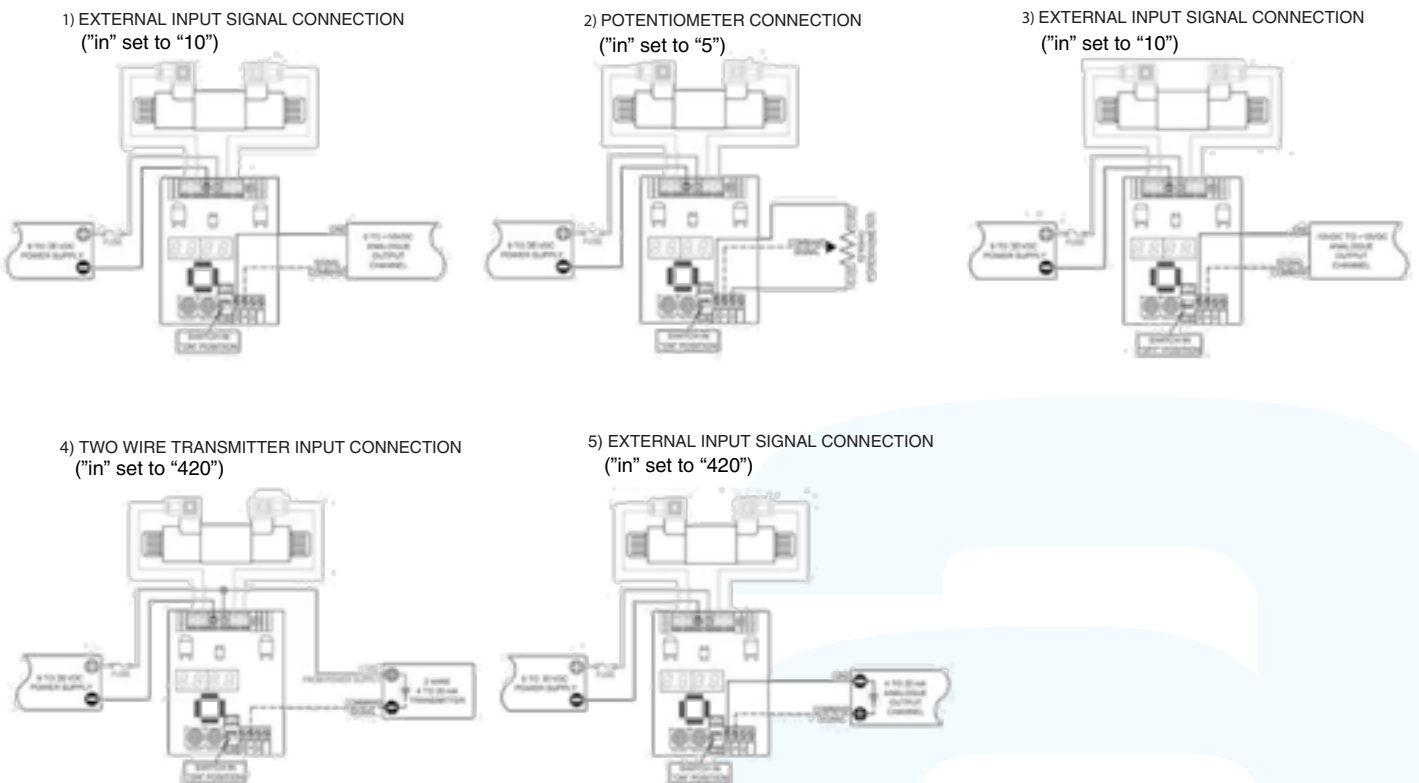

Note: for "0 to 5 VDC" and "0 to 10 VDC" command input drivers, it is recommended to use independent negative conductors for power supply and analogue output channel (PLC/PC) to maintain command signal accuracy due to voltage drop on long cable runs.

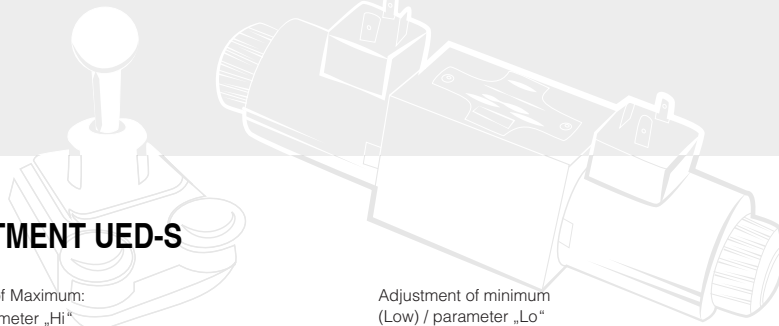

## 8 ADJUSTMENT UED-S

Adjustment of Maximum:  
(High) / parameter „Hi“  
Maximum Current output 0,20 - 3,00 A

Adjustment of minimum  
(Low) / parameter „Lo“  
Maximum Current output 0,00 - 2,99 A

Adjustment Ramp  
(Ramp up) / parameter „rUP“  
Time for Output to Increase from min to max, 0 - 99,5s

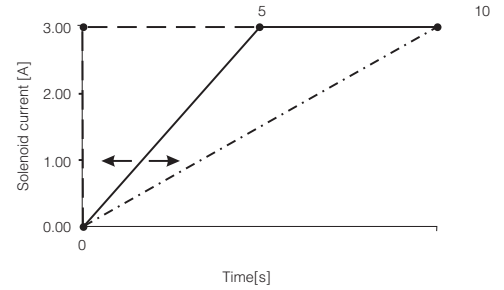
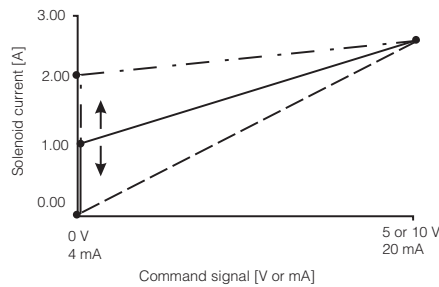
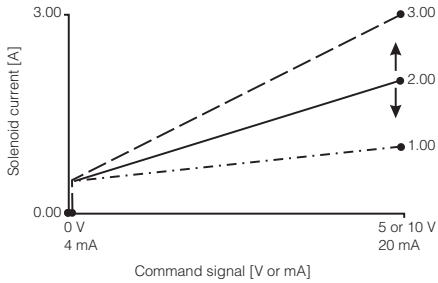

Adjustment Ramp  
(Ramp down) / parameter „rdn“  
Time for Output to Decrease from max to min 0 - 99,5 s

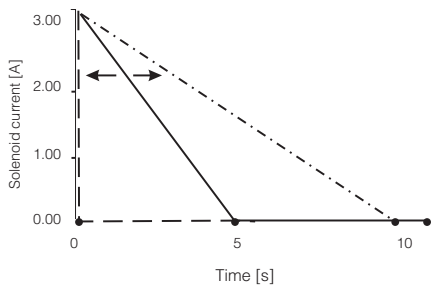

Adjustment (Command deadband) / parameter „Cdb“  
Output disabled if command signal less than deadband  
0 - 5 % of the maximum Command signal

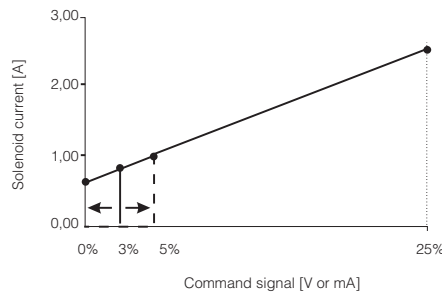

DITHER FREQUENCY / parameter „dFr“  
Frequency settable in a range of 40 - 450 Hz

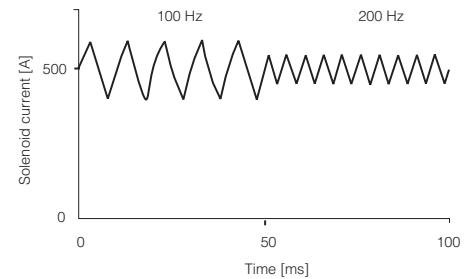

## 9 ADJUSTMENT UED-D

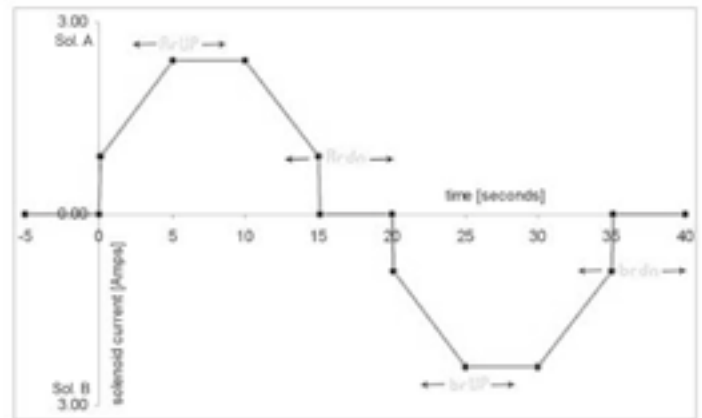
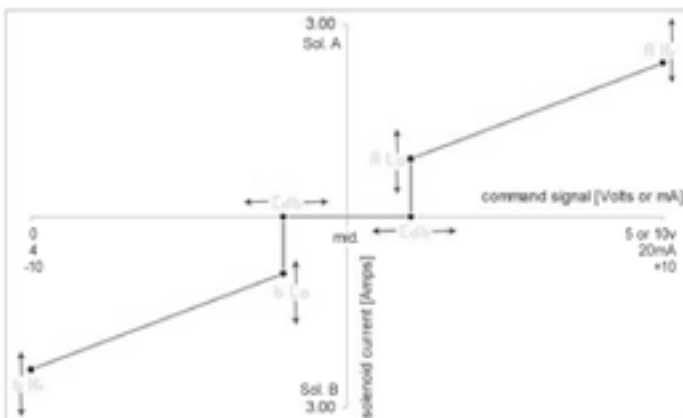

This product has been designed and tested to meet specific standards outlined in the EMC 2004/108/EC  
Emission: EN 61000-6-4:2007  
Immunity: EN 61000-6-2: 2005, EN 61000-4-2, EN 61000-4-4, EN 61000 4-6

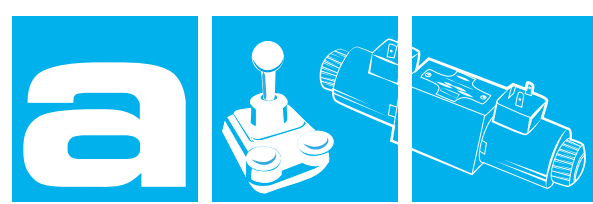

## UNIVERSAL ELECTRONIC DRIVER UED-KA

for solenoid operated proportional valves

### 1 DESCRIPTION

The driver controls one solenoid of a proportional valve. His construction permits an easy assembly directly on the ISO 4400 connection on the valve. By the use of two selectors it is possible to easily configure all the parameters without the need of special tools or programming devices.

A 3 digit led display shows all the necessaries informations.



### 2 ORDERING CODE

(1)		(2)
UED	-	KA

### 3 SET UP PROCEDURE

- (1) At power up, the display will show either the output current signal or the input signal (Default display setting shows the output signal). The decimal point will be flashing.
- (2) Rotate SELECT to enter the set-up mode. Parameter abbreviation is indicated on the display
- (3) When you reach the setting you want to modify, rotate ADJUST up or down to the desired value.
- (4) To modify another setting, rotate SELECT again and repeat.
- (5) The Driver is fully functional during the set-up procedure with any adjustments effective immediately.
- (6) In order to write the new settings in the memory and return to normal mode of operation, rotate „SELECT“ until the display shows „SR“ and then rotate „ADJUST“ from 0 to 1 or wait for 100 seconds.
- (7) If you do not want to save the new settings you have just modified, you must disconnect the Driver from the power supply before the end of the 100 seconds to restore precious settings.
- (8) After saving parameters to memory, the decimal point will be flashing and the Driver display will be back showing either the output current signal or input signal depending on your „di“ selection.
- (9) To start over completely, you can restore the factory settings by rotating SELECT to rFP and then rotate ADJUST up past 10 for the display to reset (NOTE for Step 9: you may have to adjust your Input Signal Setting again if you reset to factory settings.)

### 4 TECHNICAL DATA

Operating voltage:	9-36 V DC
Maximum output current:	3,00 A
Input signal:	0-5 V; 0-10V; 4-20 mA
Maximum ramp time:	99,5 s
Linearity:	40-450 Hz
Operating Temperature:	-40 .. 75 °C
Protection grade:	IP 65*
Recommended cross section of wires:	0,5 .. 0,75 mm <sup>2</sup>
Mounting:	DIN 43650-A/ISO4400 solenoid and cable connector

\* A cable with a circular cross section and outside diameter of 4 .. 6 mm should be used for the electronics supply. Only in this way the declared IP protection can be assured.

### 5 KEY FEATURES

- Microcontroller design
- Independent adjustments (ramp up - ramp down)
- 3 digit led display
- Display and adjust actual values (current&voltage)
- Easy access to the menu setup
- Wide ramp time range
- Simple control with analog input, locally supplied reference voltage
- No heat sink required
- Electronic limiting circuit/short circuit proof
- Reverse polarity, command input protection
- Load can be connected and disconnected live



## 6 SETTING RANGES

Parameter	Description	Adjustable Range
Hi *	HIGH, Maximum Current Output	0,20 - 3,00 A
Lo *	LOW, Minimum Current Output (see note 1)	0,00 - 2,99 A
rUP *	RAMP UP, Time for Output to increase from min to max	0,0 - 99,5 s
rdn *	RAMP DOWN, Time for Output to decrease from max to min	0,0 - 99,5 s
Cdb	COMMAND DEADBAND, Output disabled if command signal is less then deadband	0 - 5 %
dFr	DITHER FREQUENCY	40 - 450 Hz
in	INPUT SIGNAL SELECTION: 5 - Voltage signal 20 - Voltage signal 420 - Current signal	0 - 5 V 0 - 10 V 4 - 20 mA
di	DISPLAYED SIGNAL FOR TROUBLESHOOTING: 0 - Command signal [V] or [mA] 1 - Output signal [A] **Flashing decimal point is an indicator for present display mode** - Fast flashing decimal point, several flashes per second indicates di=0 - Slow flashing decimal point, 1 per second indicates di=1 - No flashing decimal point or no decimal point indicates display in SETTING/ADJUST	
SA	SAVE SETTINGS	
rFP	RESET FACTORY PARAMETERS (see note 2)	
Err	ERROR DETECTION STATE, short circuit, reverse polarity protection and detection: 0 - Error 0 - No errors 1 - Error 1 - Overcurrent in driver likely due to short circuit in Solenoid 2 - Error 2 - Current exceeding 20 mA in 4-20 mA input mode	
CLr	CLEAR ERROR, clear driver or error state (see note 2)	
NOTE 1	When adjusting the HI and LO parameters, note the HI parameter value cannot be adjusted below the LO parameter value as well the LO parameter value cannot exceed the HI parameter value.	
NOTE 2	Adjust Parameter value up past 9 to operate this command setting	

## 7 INSTALLATION DIMENSIONS (mm)

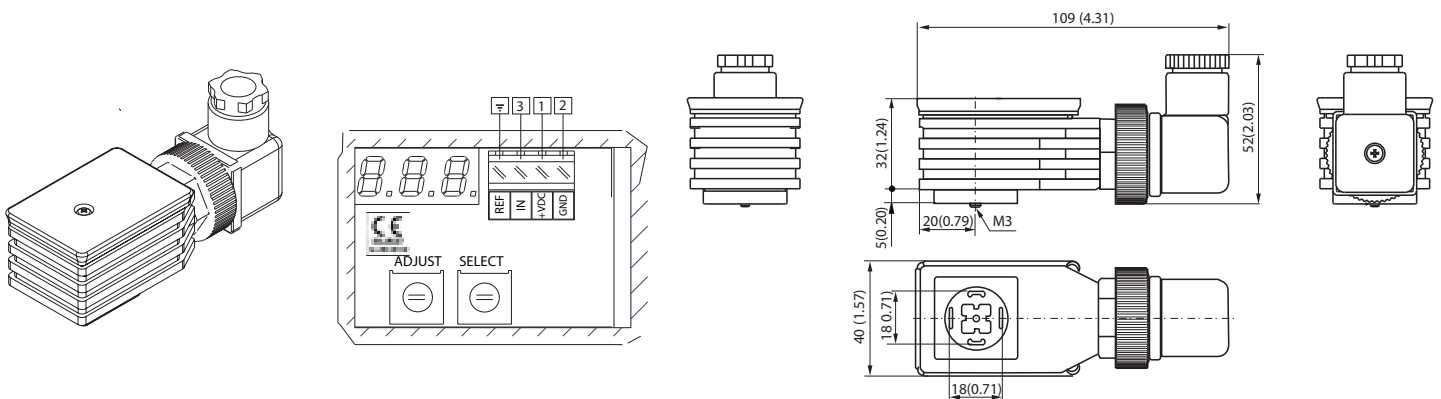

## 8 SCHEMATICS

1) EXTERNAL INPUT SIGNAL CONNECTION  
("in" set to "10")

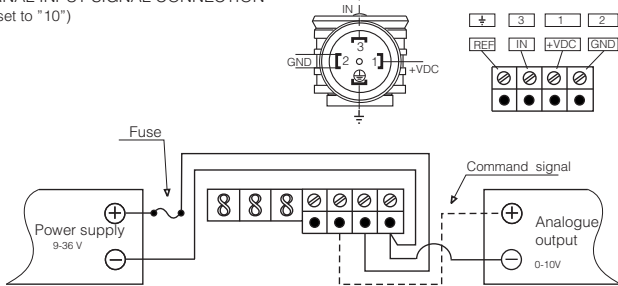

2) POTENTIOMETER CONNECTION  
("in" set to "5")

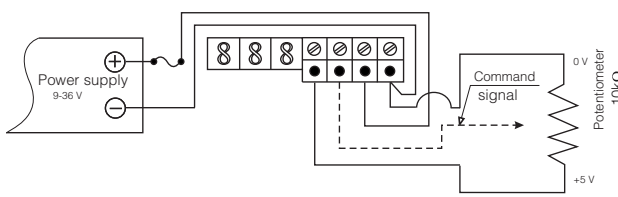

3) RAMP UP & DOWN ONLY OPERATION  
("in" set to "5")

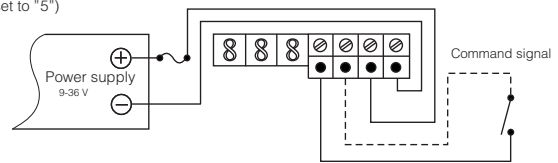

4) EXTERNAL INPUT SIGNAL CONNECTION 4-20 mA  
("in" set to "420")

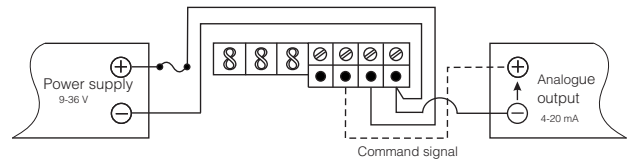

5) TWO WIRE TRANSMITTER INPUT CONNECTION 4-20 mA  
("in" set to "420")

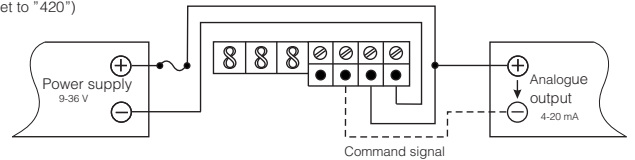

## 9 ADJUSTMENT

Adjustment of Maximum:  
(High) / parameter „Hi“  
Maximum Current output 0,20 - 3,00 A

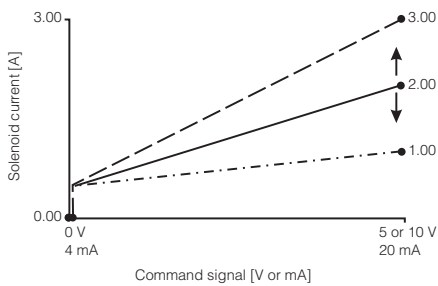

Adjustment of minimum  
(Low) / parameter „Lo“  
Maximum Current output 0,00 - 2,99 A

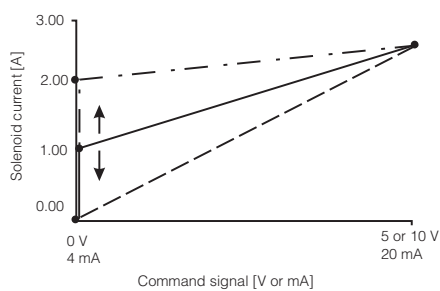

Adjustment Ramp  
(Ramp up) / parameter „rUP“  
Time for Output to Increase from min to max, 0 - 99,5 s

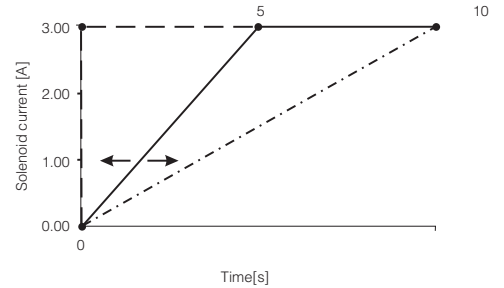

Adjustment Ramp  
(Ramp down) / parameter „rDn“  
Time for Output to Decrease from max to min 0 - 99,5 s

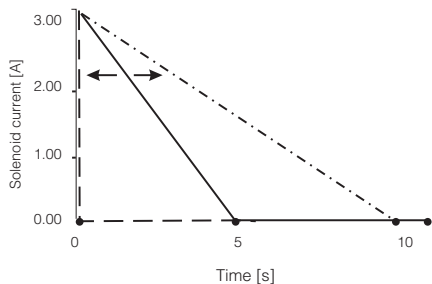

Adjustment (Command deadband) / parameter „Cdb“  
Output disabled if command signal less than deadband  
0 - 5 % of the maximum Command signal

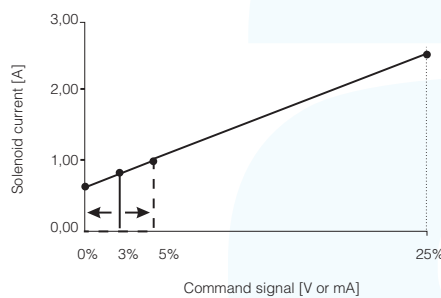

DITHER FREQUENCY / parameter „dFr“  
Frequency settable in a range of 40 - 450 Hz

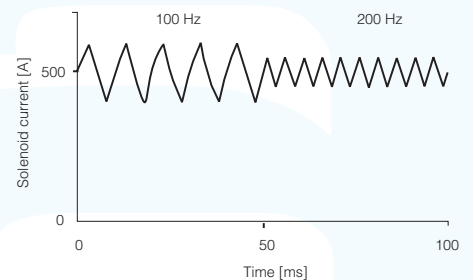

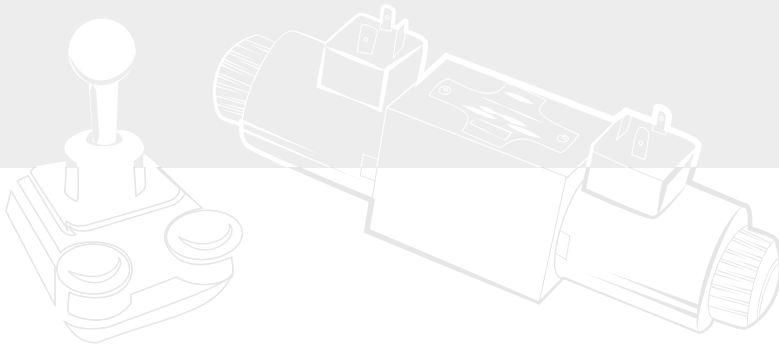



## **8** CARTRIDGE VALVES SAE8-SAE10

SCREW IN, 2-WAY SOLENOID OPERATED POPPET VALVES NORMALLY CLOSED CAVITY 3/4" 16 UNF Ø 12,7 mm ONE DIRECTIONAL FLOW <b>EVSC.34.02</b>	0001
SCREW IN, 2-WAY SOLENOID OPERATED POPPET VALVES NORMALLY CLOSED CAVITY 3/4" 16 UNF Ø 15,87 mm ONE DIRECTIONAL FLOW <b>EVSC.34/2.02</b>	0003
SCREW IN, 2-WAY SOLENOID OPERATED POPPET VALVES NORMALLY CLOSED CAVITY 3/4" 16 UNF Ø 12,7 mm ONE DIRECTIONAL FLOW <b>EVC.34.</b>	0005
SCREW IN, 2-WAY SOLENOID OPERATED POPPET VALVES NORMALLY CLOSED CAVITY 3/4" 16 UNF Ø 12,7 mm TWO DIRECTIONS FLOW <b>EVC2.34.</b>	0007
SCREW IN, 2-WAY DIRECT OPERATED POPPET VALVES, BI-DIRECTIONAL CONTROL CAVITY 3/4" 16 UNF Ø 12,7 mm <b>EVD.34.</b>	0009
SCREW IN, 2-WAY SOLENOID OPERATED POPPET VALVES NORMALLY CLOSED, BI-DIRECTIONAL CONTROL CAVITY 3/4" 16 UNF Ø 12,7 mm <b>EVD2.34.</b>	0011
SCREW IN, 2-WAY SOLENOID OPERATED POPPET VALVES NORMALLY CLOSED, BI-DIRECTIONAL CONTROL CAVITY 3/4" 16 UNF Ø 15,87 mm <b>EVD2.34/2</b>	0013
SCREW IN, 2-WAY SOLENOID OPERATED POPPET VALVES NORMALLY OPEN, ONE DIRECTIONAL FLOW CAVITY 3/4" 16 UNF Ø 12,7 mm <b>EVO.34.</b>	0015
SCREW IN, 2-WAY SOLENOID OPERATED POPPET VALVES NORMALLY OPEN, BI DIRECTIONAL FLOW CAVITY 3/4" 16 UNF Ø 12,7 mm <b>EVO2.34.</b>	0017
SCREW IN, 2-WAY SOLENOID OPERATED SPOOL TYPE DIRECTIONAL VALVES CAVITY 3/4" 16 UNF-SAE 08/2 <b>EV*2*.34.*</b>	0019
SCREW IN, 3-WAY SOLENOID OPERATED DIRECTIONAL VALVE CAVITY 3/4" 16 UNF-SAE 08/3 <b>EV3*.34.*</b>	0022



# **8 CARTRIDGE VALVES** **SAE8-SAE10**

SCREW IN, 2-WAY SOLENOID OPERATED DIRECTIONAL VALVES

CAVITY 3/4" 16 UNF-SAE 08/4

**EV4\*\* .34.\*** 0025

30 mm COIL SERIES

**C30 COILS** 0028

36 mm COIL SERIES

**C36 COILS** 0029

SCREW IN POPPET CHECK VALVE CAVITY 3/4" 16 UNF

**VUC-34\*** 0030

HYDRAULIC SCREW-IN VALVES PRESSURE RELIEF-DIRECT ACTING

**MO-010** 0031

HYDRAULIC SCREW-IN VALVES PRESSURE RELIEF-DIRECT ACTING

**MO-020** 0033

HYDRAULIC SCREW-IN VALVES FLOW CONTROL-ADJUSTABLE

**FT266/VCF** 0035

HYDRAULIC SCREW-IN FLOW CONTROL VALVES- PRESSURE COMPENSATED

**VQF** 0037

LINE ASSEMBLY BODIES FOR 2-WAY SCREW-IN VALVES

**LAB** 0039

HYDRAULIC SCREW-IN VALVES PRESSURE RELIEF-DIRECT ACTING

**MO-4** 0040

HYDRAULIC SCREW-IN VALVES PRESSURE RELIEF-DIRECT ACTING

**MO-4L** 0042

SCREW-IN, 2-WAY SOLENOID OPERATED DIRECTIONAL VALVE CAVITY 7/8" UNF-SAE 10/2 spool type

**EV2\* .78.\*** 0044

SCREW-IN, 3-WAY SOLENOID OPERATED DIRECTIONAL VALVE CAVITY 7/8" 14 UNF-SAE 10/3 spool type

**EV3\* .78.\*** 0047

SCREW-IN, 4-WAY SOLENOID OPERATED DIRECTIONAL VALVE CAVITY 7/8" 14 UNF-SAE 10/4 spool type

**EV4\*\* .78.\*** 0050

**aidro**  
hydraulics



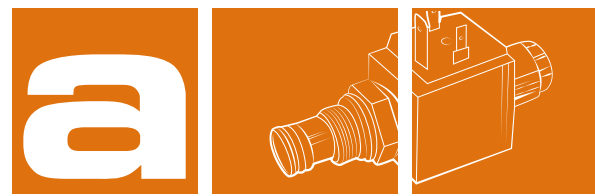

SCREW IN, 2-WAY SOLENOID OPERATED POPPET VALVES NORMALLY CLOSED,  
CAVITY 3/4" 16 UNF Ø 12,7 mm ONE DIRECTIONAL FLOW

## EVSC.34.02

32 l/min 25 MPa (250 bar)

### 1 DESCRIPTION

The valve is 2 way NC poppet type and full optional. It is complete with filter, manual override scREW type, protection cover for the manual override. With his design, it is possible to use the valve with standard coils suitable for AC and DC current without the need of special connectors with integrated rectifiers.



### 2 ORDERING CODE

(1)	(2)	(3)	(4)	(5)	(6)	(7)
EVSC	-	34	-	02	-	-

(1) EVSC : screw in directional solenoid valve with Ø 13 mm solenoid core (see 5),  
2 way, 2 position, poppet type, normally closed, one direction flow

(2) 34 : cavity 3/4" 16 UNF (Ø 12,7 mm)

(3) 02 : filter and manual override of screw type

(4) Electric voltage and solenoid coil (see 8)

- 0000: no coil
- 012C: coil for V 12 DC
- 024C: coil for V 24 DC
- 220R: coil for V 220-230 RAC
- 230/50:coil for V 230/50 AC

(5) Options for coils connections

- no designation: standard connection ISO 4400 / DIN 43650/A
- C: flying leads
- A: AMP Junior

(6) Options for ISO 4400 / DIN 43650/A connectors

- B9: standard connector, black PG9
- D9: black connector, with diode, PG9
- ES: "energy saving" connector with LED
- R\*: rectifier bridge
- L\*: LED
- V\*: LED + varistor

(7) Protective cap on manual override: P

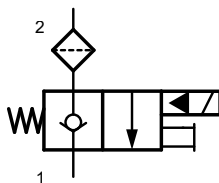
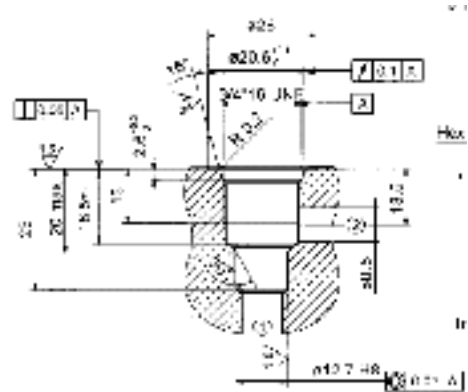

The poppet 7 is pilot operated and it is kept normally closed against its seat 8. When the solenoid is energized, the mobile armature 5 and the pilot pin 17 are shifted and the poppet, unbalanced by pressure, opens permitting flow from 1 to 2. The manual override 1 is of screw type and permits the valve operation in case of electric failure. The filter 18 (0,25 mm) prevents from dirt and better diffuses the flow around the poppet. The cap 2 protects from shocks the manual override and, if locked, may prevent undue tampering of the valve.

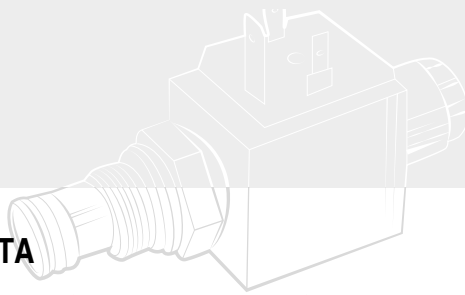

### 3 TECHNICAL DATA

Max. nominal pressure	25 MPa (250 bar)	Electric Characteristics: Those solenoid valves are normally equipped by coils type C30, which are energized from DC or AC supply. Coils type C30-***C are DC energized directly from a V***DC supply. Coils type C30-***R are RAC (Rectified Alternate Current) energized from a V***AC supply, by a full wave bridge rectifier incorporated in the connector. Solenoids valves type EVSC.34 can also be AC energized, directly from a V***AC supply, by using appropriate C30-***/50 or C30-***/60 coils. Coils type C30 are normally provided for use of ISO 4400 / DIN 43650/A connectors. For coils with different connection to the power supply, see table C30
Nominal flow rate	32 l/min	
Max. rec. flow rate	40 l/min	

### 4 INSTALLATION DIMENSIONS (mm)

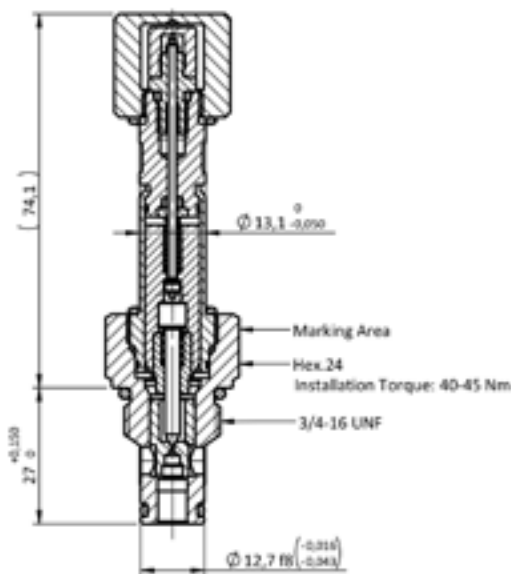

EVSC.34 valves are to be installed in cavity 3/4" 16 UNF with Ø 12,7 mm. Check the appropriate state and position of the seals supplied with the valve :

- O-Ring 9,25 x 1,78 with parbak 9,91 x 1,35
- O-Ring 16,36 x 2,20
- 2 x O-Ring 12,42 x 1,78

Screw the valve in the cavity and lock it with a torque of about 45 Nm applied on the 24mm hexagon.

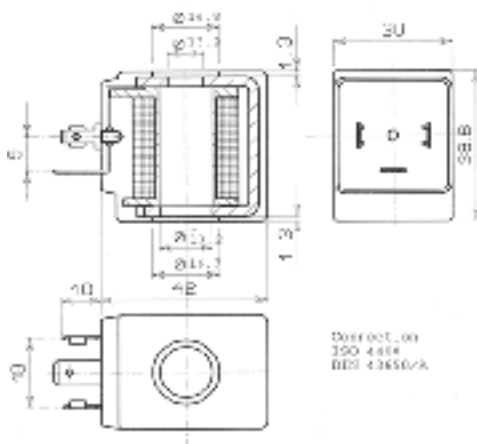

### 5 TYPICAL DIAGRAMS

(measured at  $v=46$  cSt and  $40^{\circ}\text{C}$ )

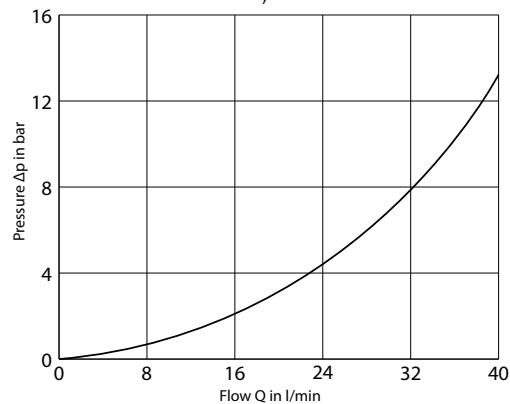

### 6 CONNECTORS

Standard coils are compatible with KA-132 connectors; for some functions ( $R^*$  = bridge rectifier;  $L^*$  = LED, etc.) the voltage has to be specified:

$$1 = V12 - V24 \quad 2 = V115 \quad 3 = V230$$

The "energy saving" connectors (option ES) save current consumption to less than 50% of the nominal and strongly reduce warming up of the coils.

### 7 COILS TYPE C30 (Ø 13mm)

Coils	voltage DC/RAC	nominal current (A)	resistance $20^{\circ}\text{C}$ ( $\Omega$ )	nominal power (W)	insulation class
C30-012C	V 12 DC	1,55	7,7	18,6	F
C30-024C	V 24 DC	0,8	31	19	
C30-024R	V 24 RAC	0,85	27	18,3	
C30-048C	V 48 DC	0,4	116	19	
C30-048R	V 48 RAC	0,4	106	17,3	
C30-110R	V 110-115 RAC	0,16	600	16	
C30-220R	V 220-230 RAC	0,08	2500	16	
	<b>AC</b>	<b>(*)</b>		<b>(VA) (*)</b>	
C30-024/50	24V 50 Hz	0,9	5,3	35	F
C30-110/50	110-115V 50 Hz	0,2	108		
C30-230/50	220-230V 50 Hz	0,1	438		
C30-110/60	110-115V 60 Hz	0,3	92		
C30-220/60	220-230V 60 Hz	0,15	375		

(\*) Caution : with AC operation, the inrush current can be up to 3-4 times the nominal holding value



**SCREW IN, 2-WAY SOLENOID OPERATED POPPET VALVES NORMALLY CLOSED,  
CAVITY 3/4" 16 UNF Ø 15,87 mm ONE DIRECTIONAL FLOW**

**EVSC.34/2.02**  
32 l/min 25 MPa (250 bar)

## 1 DESCRIPTION

The valve is 2 way NC poppet type and full optional. It is complete with filter, manual override screw type, protection cover for the manual override. With his design, it is possible to use the valve with standard coils suitable for AC and DC current without the need of special connectors with integrated rectifiers. This valve has a special design with a 3/4" 16 UNF thread but with a 15,87 mm nose thus permits a lower pressure drop. A special dual seal ring on the nose permits an efficient and reliable sealing system.



## 2 ORDERING CODE

(1)	(2)	(3)	(4)	(5)	(6)	(7)	(8)
EVSC	-	34	/	2	-	02	-

(1) EVSC : screw in directional solenoid valve, valve with Ø 13 mm solenoid core (see 4), 2 way, 2 position, poppet type, normally closed, one direction flow

(2) 34 : cavity 3/4" 16 UNF

(3) 2 : with Ø 15,87 mm (see 4)

(4) 02 : filter and manual override

(5) Electric voltage and solenoid coil (see 3, see 7)

0000: no coil  
012C: coil for V 12 DC  
024C: coil for V 12 DC  
220R: coil for V 220-230 RAC  
230/50: coil for V 230/50 AC

(6) Options for coils connections

no designation: standard connection ISO 4400 / DIN 43650/A  
C: flying leads  
A: AMP Junior

(7) Options for ISO 4400 / DIN 43650/A connectors

B9: standard connector, black PG9  
D9: black connector, with diode, PG9  
ES: "energy saving" connector with LED  
R\*: rectifier bridge  
L\*: LED  
V\*: LED + varistor

(8) Protective cap on manual override: P

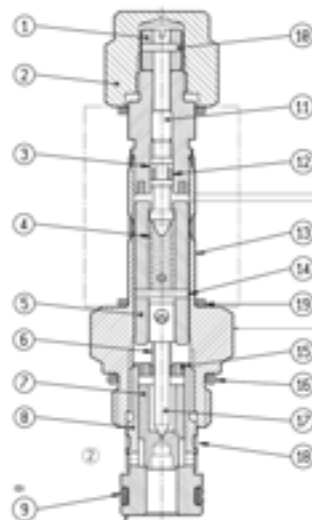
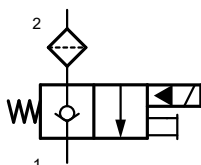
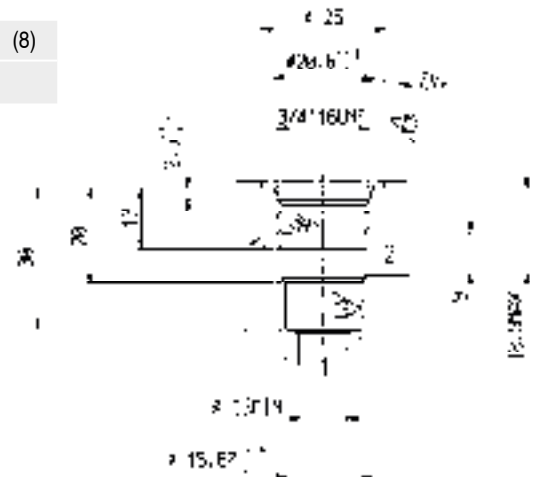

The poppet 7 is pilot operated and it is kept normally closed against its seat 8. When the solenoid is energized, the mobile armature 5 and the pilot pin 17 are shifted and the poppet, unbalanced by pressure, opens permitting flow from 2 to 1.

The manual override 1 is of screw type and permits the valve operation in case of electric failure. The filter 18 (0,25 mm) prevents from dirt and better diffuses the flow around the poppet.





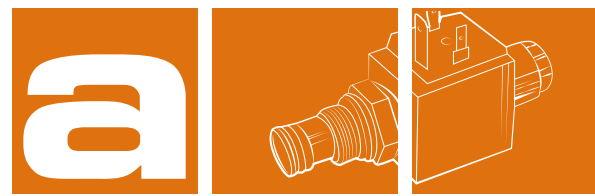

SCREW IN, 2-WAY SOLENOID OPERATED POPPET VALVES NORMALLY CLOSED,  
CAVITY 3/4" 16 UNF Ø 12,7 mm ONE DIRECTIONAL FLOW

## EVC.34.

40 l/min 25 MPa (250 bar)

### 1 DESCRIPTION

The valve is a pilot operated 2 way NC poppet type. It is the basic valve without manual override and filter.

With his design, it is possible to use the valve with standard coils suitable for AC and DC current without the need of special connectors with integrated rectifiers.



### 2 ORDERING CODE

(1)	(2)	(3)	(4)	(5)	(6)
EV	C	- 34	-	-	-

- (1) EV : screw-in directional solenoid valve
- (2) C : valve with Ø 13 mm solenoid core (see 4), 2 way, 2 position, poppet type, normally closed, one direction flow
- (3) 34 : cavity 3/4 " 16 UNF with Ø 12,7 mm - see A
- (4) Electric voltage and solenoid coil (see 3, see 7 )
  - 0000 : no coil
  - 012C : coil for V12DC
  - 024C : coil for V24DC
  - 220R : coil for V220-230 RAC
  - 230/50 : coil for V230/50 AC
- (5) Options for coil connection (see 3 )
  - no designation : standard connection ISO4400/DIN 43650/A
  - C : flying leads;
  - A: AMP Junior
- (6) Options for ISO4400/DIN 43650/A connectors(see 6 )
  - B9 : standard connector, black PG9
  - D9 : black connector, with diode, PG9
  - ES : "energy saving" connector with LED
  - R\* : rectifier bridge;
  - L\*:LED;
  - V\*:LED+varistor

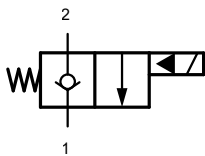
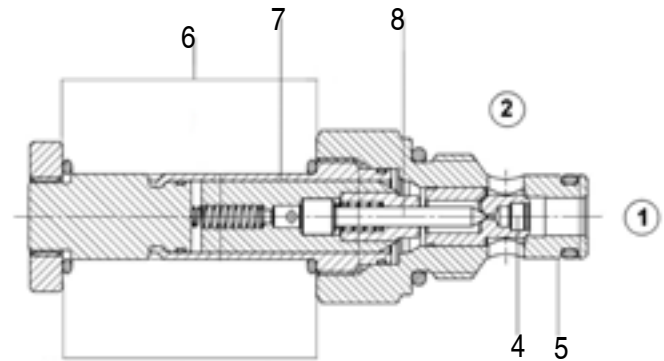
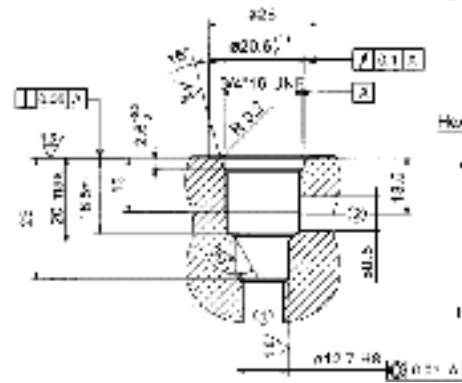

The poppet 4 is pilot operated and it is kept normally closed against its seat 5. When the solenoid 6 is energized, the mobile armature 7 and the pilot pin 8 are shifted and the poppet, unbalanced by pressure, opens permitting flow from 2 to 1.

### 3 TECHNICAL DATA

Max. nominal pressure	25 MPa (250 bar)	Electric Characteristics: Those solenoid valves are normally equipped by coils type C30, which are energized from DC or AC supply (see ). Coils type C30-***C are DC energized directly from V***DC supply. Coils type C30-***R are RAC (Rectified Alternate Current) energized from a V***AC supply, by a full wave bridge rectifier incorporated in the connector. Solenoid valves type EVC.34. can also be AC energized, directly from a V***AC supply, by using appropriate C30-***/50 or C30-***/60 coils. (*) Caution : with AC operation, the inrush current can be up to 3-4 times the nominal holding value. Coils type C30 are normally provided for use of ISO 4400/DIN 43650/A connectors. For coils with different connection to the power supply, see table C30/36.
Nominal flow rate	32 l/min	
Max. rec. flow rate	40 l/min	
Dimension and installation	see 4	
Duty cycle	ED 100%	
Mass (without coil)	0,120 kg	

### 4 INSTALLATION DIMENSIONS (mm)

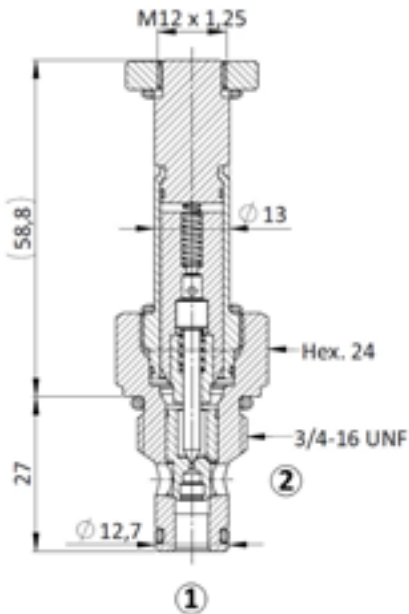

EV\*.34 valves are to be installed in cavity 3/4" 16 UNF with Ø 12,7 mm. Check the appropriate state and position of the seals and , screw the valve in the cavity and lock it with a torque of about 45 Nm applied on the 24 mm hexagon.

### 5 PRESSURE DROPS

Viscosity 42 cSt at 50°C.

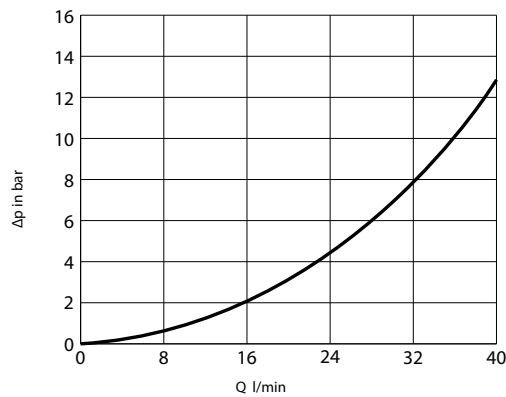

### 6 CONNECTORS

Standard coils are compatible with KA-132 connectors; for some functions (R\* = bridge rectifier, L\* = LED, etc.) the voltage has to be specified :

1 = V12, V24    2 = V115    3 = V230

The "energy saving" connectors – option ES – save current consumption to less than 50% of the nominal and strongly reduce warming up of the coils.

### 7 COILS TYPE C30 ( Ø 13mm- 18w: 35 VA)

Coils ISO/DIN	voltage DC/RAC	nominal current (A)	resistance 20° C (Ω)	nominal power (W)	insulation class
C30-012C	V 12 DC	1,55	7,7	18,6	F
C30-024C	V 24 DC	0,8	31	19	
C30-024R	V 24 RAC	0,85	27	18,3	
C30-048C	V 48 DC	0,4	116	19	
C30-048R	V 48 RAC	0,4	106	17,3	
C30-110R	V 110-115 RAC	0,16	600	16	
C30-220R	V 220-230 RAC	0,08	2500	16	
	<b>AC</b>	<b>(*)</b>		<b>(VA) (*)</b>	
C30-024/50	24V 50 Hz	0,9	5,3	35	F
C30-110/50	110-115V 50 Hz	0,2	108		
C30-230/50	220-230V 50 Hz	0,1	438		
C30-110/60	110-115V 60 Hz	0,3	92		
C30-220/60	220-230V 60 Hz	0,15	375		

(\*) Caution : with AC operation, the inrush current can be up to 3-4 times the nominal holding value

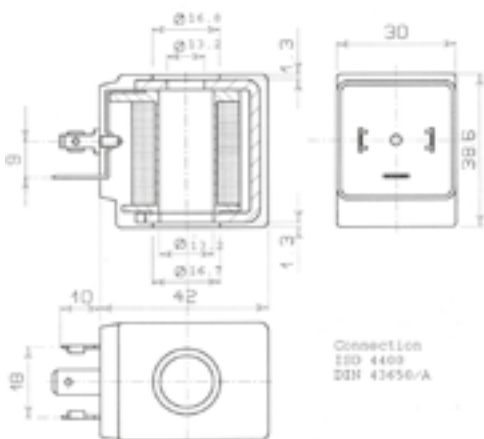

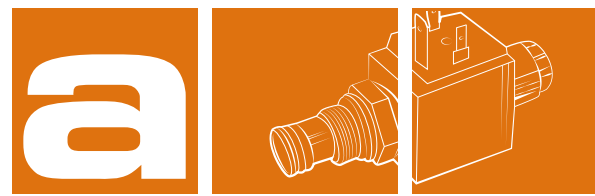

## SCREW IN, 2-WAY SOLENOID OPERATED POPPET VALVES NORMALLY CLOSED, CAVITY 3/4" 16 UNF Ø 12,7 mm TWO DIRECTIONS FLOW

### EVC2.34.

40 l/min 25 MPa (250 bar)

#### 1 DESCRIPTION

The valve is a pilot operated 2 way NC poppet type with bi directional flow. It is available in different configurations. With his design, it is possible to use the valve with standard coils suitable for AC and DC current without the need of special connectors with integrated rectifiers.



#### 2 ORDERING CODE

(1)	(2)	(3)	(4)	(5)	(6)	(7)
EV	C2	- 34	-	-	-	-

- (1) EV : screw-in directional solenoid valve
- (2) C2 : valve with Ø 13 mm solenoid core (see 4), 2 way, 2 position, poppet type, normally closed, two directions flow
- (3) 34 : cavity 3/4 " 16 UNF with Ø 12,7 mm
- (4) Valves variants
  - 01: filter
  - 02: filter and manual override
  - 03: --
  - 04: manual override
  - P\*: manual override protection
- (5) Electric voltage and solenoid coils (see 7)
  - 0000: no coil
  - 012C: coil for V12DC
  - 024C: coil for V24DC
  - 220R: coil for V220-230 RAC
  - 230/50: coil for V230/50 AC
- (6) Options for coil connection
  - no designation: standard connection ISO4400/DIN 43650/A
  - C: flying leads;
  - A: AMP Junior
- (7) Options for ISO4400/DIN 43650/A connectors
  - B9: standard connector, black PG9
  - D9: black connector, with diode, PG9
  - ES: "energy saving" connector with LED
  - R\*: rectifier bridge;
  - L\*:LED;
  - V\*:LED+varistor

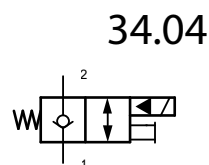
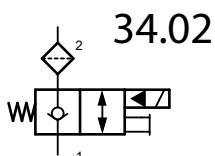
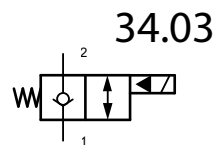
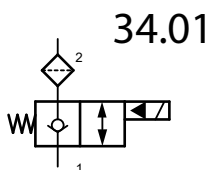
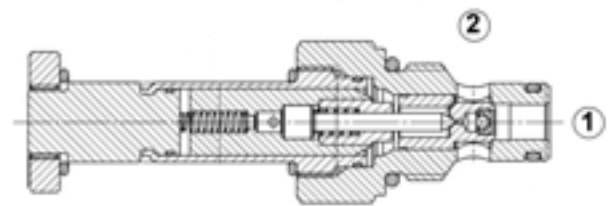
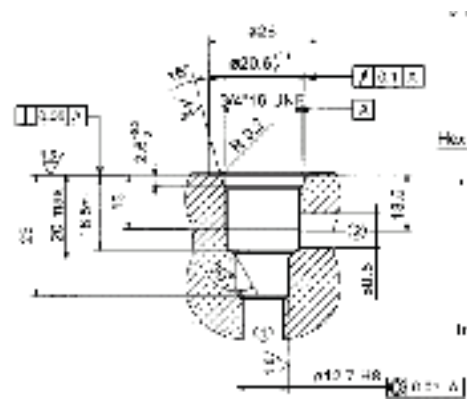

The poppet 4 is pilot operated and it is kept normally closed against its seat 5. When the solenoid 6 is energized, the mobile armature 7 and the pilot pin 8 are shifted and the poppet, unbalanced by pressure, opens permitting flow in both directions. The manual override 9 is of screw type and permits the valve operation in case of electric failure.

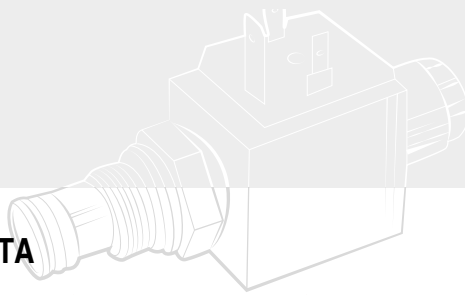

### 3 TECHNICAL DATA

Max. nominal pressure	25 MPa (250 bar)	Electric Characteristics: Those solenoid valves are normally equipped by coils type C30, which are energized from DC or AC supply. Coils type C30-***C are DC energized directly from a V***DC supply. Coils type C30-***R are RAC (Rectified Alternate Current) energized from a V***AC supply, by a full wave bridge rectifier incorporated in the connector. Solenoid valves type EVC2.34. can also be AC energized, directly from a V***AC supply, by using appropriate C30-***/50 or C30-***/60 coils. (*) Caution : with AC operation, the inrush current can be up to 3-4 times the nominal holding value. Coils type C30 are normally provided for use of ISO 4400/DIN 43650/A connectors. For coils with different connection to the power supply, see table C30/36.
Nominal flow rate	32 l/min	
Max. rec. flow rate	40 l/min	
Dimension and installation	see 4	
Duty cycle	ED 100%	
Mass (without coil)	0,120 kg	

### 4 INSTALLATION DIMENSIONS (mm)

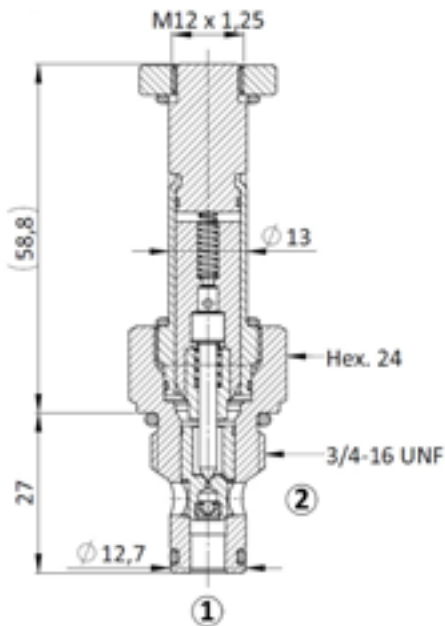

EV\*.34 valves are to be installed in cavity 3/4" 16 UNF with Ø 12,7 mm. Check the appropriate state and position of the seals and , screw the valve in the cavity and lock it with a torque of about 45 Nm applied on the 24 mm hexagon.

### 5 PRESSURE DROPS

Viscosity 42 cSt at 50°C.

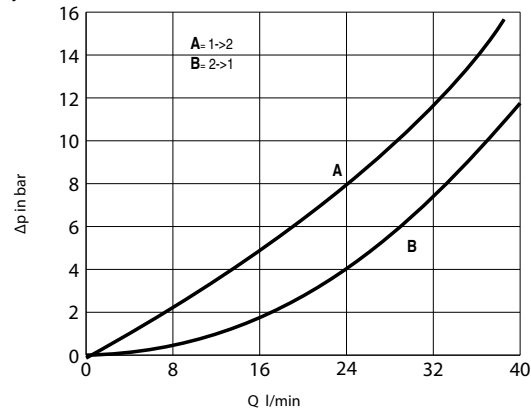

### 6 CONNECTORS

Standard coils are compatible with KA-132 connectors; for some functions (R\*= bridge rectifier, L\*= LED, etc.) the voltage has to be specified :

1 = V12, V24      2 = V115      3 = V230

The "energy saving" connectors – option ES – save current consumption to less than 50% of the nominal and strongly reduce warming up of the coils.

### 7 COILS TYPE C30 ( Ø 13mm- 18w: 35 VA)

Coils ISO/DIN	voltage DC/RAC	nominal current (A)	resistance 20° C (Ω)	nominal power (W)	insulation class
C30-012C	V 12 DC	1,55	7,7	18,6	F
C30-024C	V 24 DC	0,8	31	19	
C30-024R	V 24 RAC	0,85	27	18,3	
C30-048C	V 48 DC	0,4	116	19	
C30-048R	V 48 RAC	0,4	106	17,3	
C30-110R	V 110-115 RAC	0,16	600	16	
C30-220R	V 220-230 RAC	0,08	2500	16	F
	<b>AC</b>	<b>(*)</b>		<b>(VA) (*)</b>	
C30-024/50	24V 50 Hz	0,9	5,3	35	
C30-110/50	110-115V 50 Hz	0,2	108		
C30-230/50	220-230V 50 Hz	0,1	438		
C30-110/60	110-115V 60 Hz	0,3	92		
C30-220/60	220-230V 60 Hz	0,15	375		

(\*) Caution : with AC operation, the inrush current can be up to 3-4 times the nominal holding value

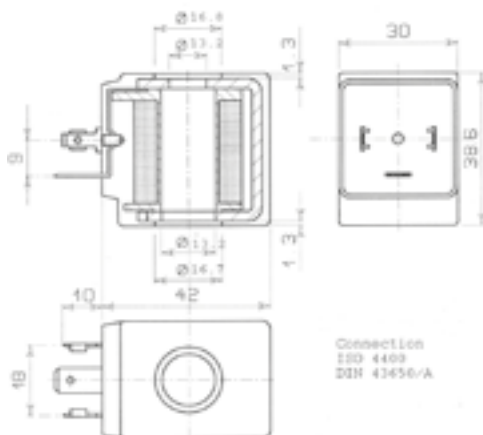

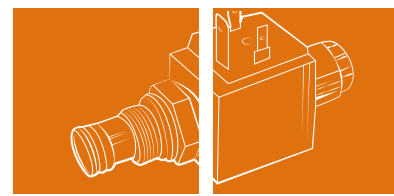

## SCREW IN, 2-WAY DIRECT OPERATED POPPET VALVES, BI-DIRECTIONAL CONTROL CAVITY 3/4" 16 UNF Ø 12,7 mm

### EVD.34.

16 l/min 25 MPa (250 bar)

#### 1 DESCRIPTION

The valve is 2 way poppet type direct operated. It is available in normally open and normally close configuration. It is possible to use the valve with standard coils suitable DC or RAC (rectified alternate current) for AC supply.

A special dual seal ring on the nose permits an efficient and reliable sealing system.



#### 2 ORDERING CODE

(1)	(2)	(3)	(4)	(5)	(6)	(7)	(8)
EV	D	-	34	-	-	-	-

(1) EV : screw-in directional solenoid valve

(2) D : valve with Ø 13 mm solenoid core (see 4), 2 way, 2 position, poppet type, bi-directional control

(3) valve configuration:  
no designation: normally closed valve  
O : normally open valve

(4) 34 : cavity 3/4 " 16 UNF with Ø 12,7 mm - see A, 6

(5) valves variants (see 8)  
02 : filter and manual override  
03 : standard without manual override  
04 : manual override

(6) Electric voltage and solenoid coils (see 3, see 7)  
0000 : no coil  
012C : coil for V12DC  
024C : coil for V24DC  
220R : coil for V220-230 RAC

(7) Options for coil connection  
no designation : standard connection ISO4400/DIN 43650/A  
FL : flying leads;  
A : AMP Junior

(8) Options for ISO4400/DIN 43650/A connectors (see 6)  
B9 : standard connector, black PG9  
D9 : black connector, with diode, PG9  
ES : "energy saving" connector with LED  
R\* : rectifier bridge  
L\* : LED  
V\* : LED+varistor

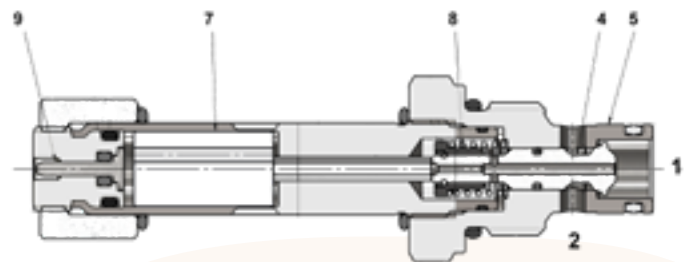
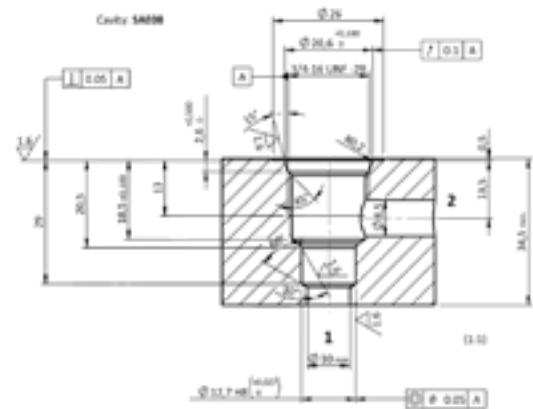

The poppet 4 is balanced by pressure and it is kept normally closed against its seat 5 by spring 8. When the solenoid is energized, the mobile armature 7 moves against spring 8 the poppet 4, thus permitting flow between 2 and 1. The manual override is of the pin type and, when pushed, it permits the valve's operation in case of electric failure .

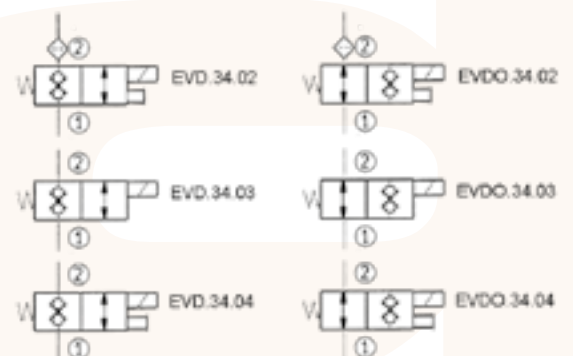

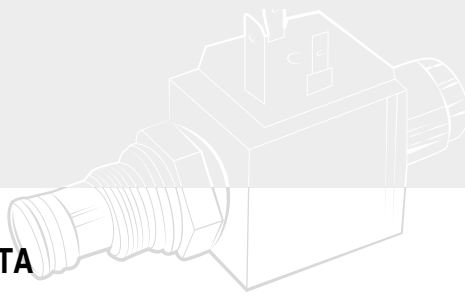

### 3 TECHNICAL DATA

Max. pressure	25 MPa (250 bar)	Electric Characteristics: Those solenoid valves are normally equipped by coils type C30, which are energized from DC or AC supply (see ). Coils type C30-***C are DC energized directly from a V***DC supply. Coils type C30-***R are RAC (Rectified Alternate Current) energized from a V***AC supply, by a full wave bridge rectifier incorporated in the connector. Solenoid valves type EVC2.34. can also be AC energized, directly from a V***AC supply, by using appropriate C30-***/50 or C30-***/60 coils (see ). (*) Caution : with AC operation, the inrush current can be up to 3-4 times the nominal holding value. Coils type C30 are normally provided for use of ISO 4400/DIN 43650/A connectors. For coils with different connection to the power supply, see table C30/36.
Nominal flow rate	10 l/min	
Max. rec. flow rate	16 l/min	
Dimension and installation	see [4]	
Duty cycle	ED 100%	
Mass (without coil)	0,120 kg	

### 4 INSTALLATION DIMENSIONS (mm)

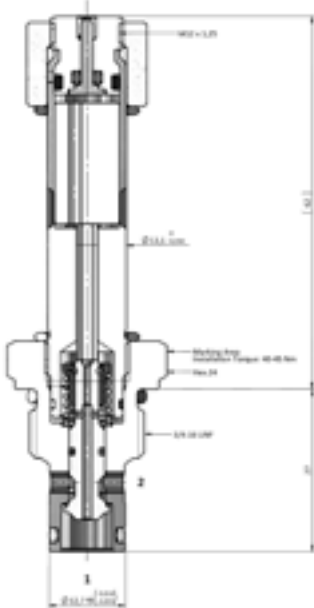

EV\*.34 valves are to be installed in cavity 3/4" 16 UNF with Ø 12,7 mm. Check the appropriate state and position of the seals and , screw the valve in the cavity and lock it with a torque of about 45 Nm applied on the 24 mm hexagon.

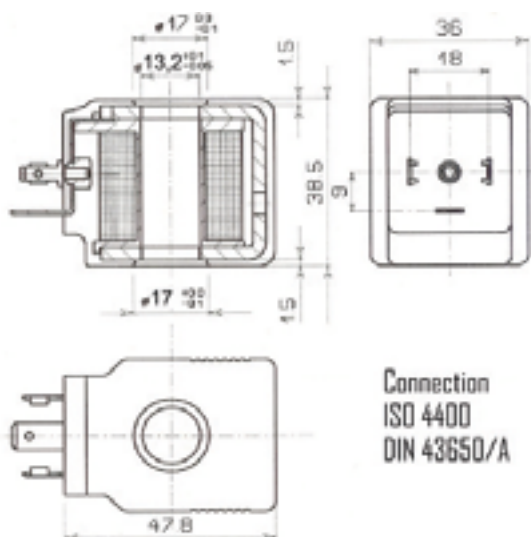

### 5 PRESSURE DROPS

Viscosity 42 cSt at 50°C.

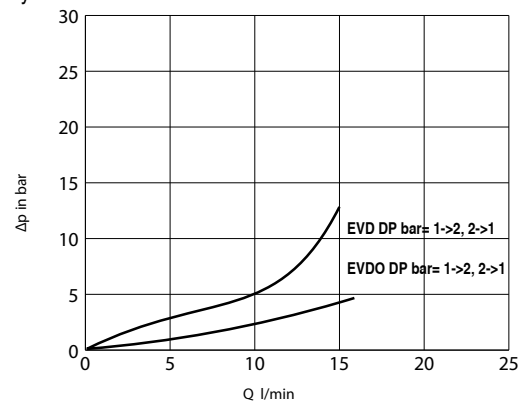

### 6 CONNECTORS

Standard coils are compatible with KA-132 connectorS ; for some functions (R\* = bridge rectifier, L\* = LED, etc.) the voltage has to be specified :

1 = V12, V24                      2 = V115                      3 = V230

The “energy saving” connectors – option ES – save current consumption to less than 50% of the nominal and strongly reduce warming up of the coils.

### 7 COILS TYPE C36 ( Ø 13mm- 22W )

Coils DIN	voltage DC	nominal current (A)	resistance 20° C (Ω)	nominal power (W)	insulation class
C36-012C	V 12 DC	1,90	6,3	22,8	H
C36-024C	V 24 DC	0,95	25,6	22,5	
C36-024R	V 24 RAC	1,05	20,2	23,0	
C36-048C	V 48 DC	0,47	102	22,6	
C36-110R	V 110-115 RAC	0,23	420	22,9	
C36-220R	V 220-230 RAC	0,11	1720	22,3	

### 8 VARIANTS

02 : filter (0,25 mm) on way prevents from dirt and better diffuses the flow around the poppet. 02 and 04 : manual override is of pin type. Push the pin to shift the poppet and open (flow between 1 to 2); release the pin to reinstall the condition of normally closed poppet (no flow between 1 to 2).

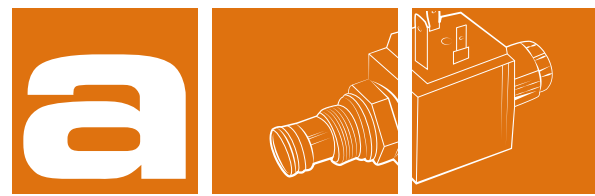

**SCREW IN, 2-WAY SOLENOID OPERATED POPPET VALVES NORMALLY CLOSED, BI-DIRECTIONAL CONTROL  
CAVITY 3/4" 16 UNF Ø 12,7 mm**

## EVD2.34.

25 l/min 21 MPa (210 bar)

### 1 DESCRIPTION

The valve is 2 way poppet type direct operated. It is available also with manual override. It is possible to use the valve with standard coils suitable DC or RAC (rectified alternat current) for AC supply.

A special dual seal ring on the nose permits an efficient and reliable sealing system.



### 2 ORDERING CODE

(1)	(2)	(3)	(4)	(5)	(6)	(7)
EV	D2	- 34	-	-	-	-

- (1) EV : screw-in directional solenoid valve
- (2) D2 : valve with Ø 13 mm solenoid core (see 4) , 2 way, 2 position, poppet type, normally closed, BI-directional-control
- (3) 34 : cavity 3/4 " 16 UNF with Ø 12,7 mm - see A
- (4) Valves variants (see 8 )
  - 01:filter
  - 02: filter and manual override
  - 03: without manual override
  - 04: manual override
- (5) Electric voltage and solenoid coils (see 3, see 7 )
  - 0000: no coil
  - 012C: coil for V12DC
  - 024C: coil for V24DC
  - 220R: coil for V220-230 RAC
- (6) Options for coil connection
  - no designation: standard connection ISO4400/DIN 43650/A
  - C: flying leads
  - A: AMP Junior
- (7) Options for ISO4400/DIN 43650/A connectors
  - B9: standard connector, black PG9
  - D9: black connector, with diode, PG9
  - ES: "energy saving" connector with LED
  - R\*: rectifier bridge;
  - L\*:LED;
  - V\*:LED+varistor

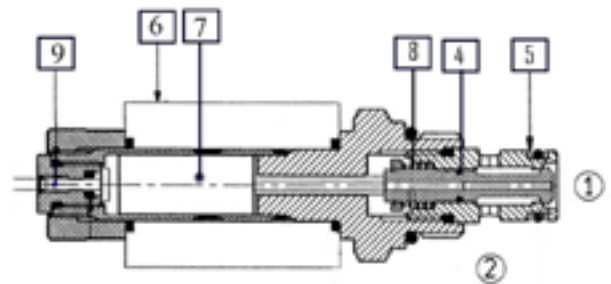
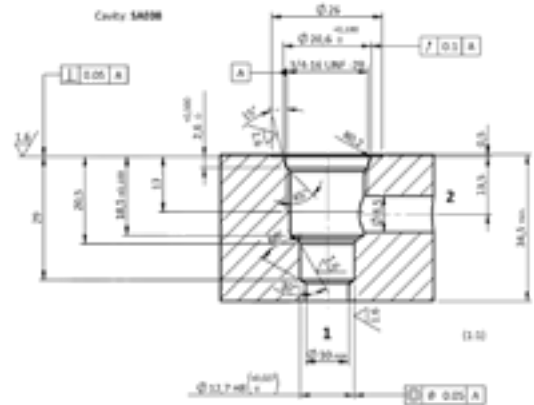

The poppet 4 is balanced by pressure and it is kept normally closed against its seat 5 by spring 8. When the solenoid 6 is energized, the mobile armature 7 moves against spring 8 the poppet 4, thus permitting flow between 2 and 1. The manual override 9 is of the pin type and, when pushed, it permits the valve's operation in case of electric failure.

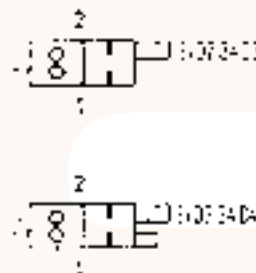



### 3 TECHNICAL DATA

Max. nominal pressure	21 MPa (210 bar)	Electric Characteristics: Those solenoid valves are normally equipped by coils type C36, which are energized from DC or AC supply. Coils type C36-***C are DC energized directly from a V***DC supply. Coils type C36-***R are RAC (Rectified Alternate Current) energized from a V***AC supply, by a full wave bridge rectifier incorporated in the connector. Coils type C36 are normally provided for use of ISO 4400/DIN 43650/A connectors. For coils with different connection to the power supply, see table C30/36.
Nominal flow rate	16 l/min	
Max. rec. flow rate	25 l/min	
Dimension and installation	see 4	
Duty cycle	ED 100%	
Mass (without coil)	0,120 kg	

### 4 INSTALLATION DIMENSIONS (mm)

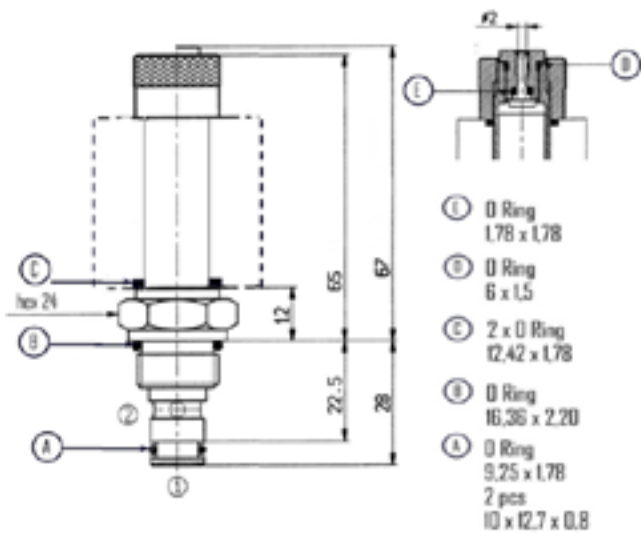

EV\*.34 valves are to be installed in cavity 3/4" 16 UNF with Ø 12,7 mm. Check the appropriate state and position of the seals and , screw the valve in the cavity and lock it with a torque of about 45 Nm applied on the 24 mm hexagon.

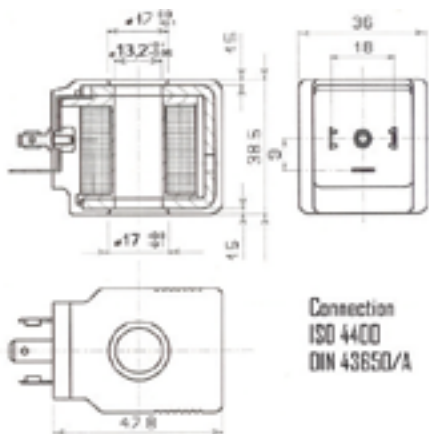

### 5 PRESSURE DROPS

Viscosity 42 cSt at 50°C.

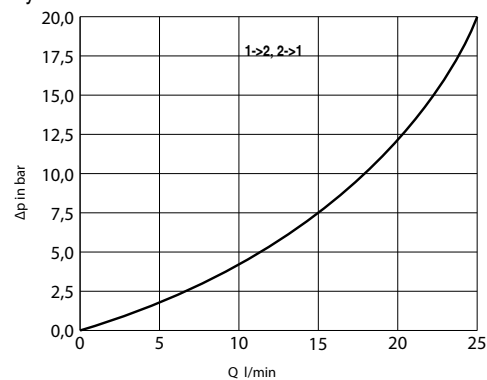

### 6 CONNECTORS

Standard coils are compatible with KA-132 connectors (see table) ; for some functions (R\* = bridge rectifier, L\* = LED, etc.) the voltage has to be specified :

1 = V12, V24                      2 = V115                      3 = V230

The “energy saving” connectors – option ES – save current consumption to less than 50% of the nominal and strongly reduce warming up of the coils.

### 7 COILS TYPE C36 ( Ø 13mm)

Coils ISO/DIN	voltage DC/RAC	nominal current (A)	resistance 20° C (Ω)	nominal power (W)	insulation class
C36-012C	V 12 DC	1,9	6,3	22,8	H
C36-024C	V 24 DC	0,95	25,6	22,5	
C36-024R	V 24 RAC	1,05	20,2	23,0	
C36-048C	V 48 DC	0,47	102	22,6	
C36-110R	V 110-115 RAC	0,23	420	22,9	
C36-220R	V 220-230 RAC	0,11	1720	22,3	

### 8 VARIANTS

01 and 02: filter (0,25 mm) on way prevents from dirt and better diffuses the flow around the poppet. 02 and 04 : manual override is of pin type. Push the pin to shift the poppet and open (flow between 1 to 2); release the pin to reinstall the condition of normally closed poppet (no flow between 1 and 2).

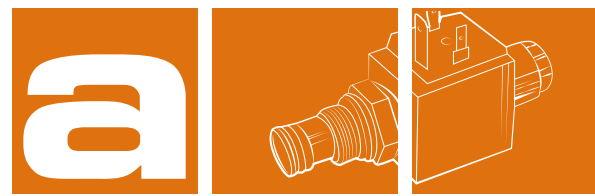

**SCREW IN, 2-WAY SOLENOID OPERATED POPPET VALVES NORMALLY CLOSED, BI-DIRECTIONAL CONTROL  
CAVITY 3/4" 16 UNF Ø 15,87 mm**

## EVD2.34/2

25 l/min 21 MPa (210 bar)

### 1 DESCRIPTION

The valve is 2 way poppet type direct operated. It is available also with manual override. It is possible to use the valve with standard coils suitable DC or RAC (rectified alternat current) for AC supply.

A special dual seal ring on the nose permits an efficient and reliable sealing system.

This valve has a special design with a 3/4" 16 UNF thread but with a 15,87 mm nose thus permits a lower pressure drop.



### 2 ORDERING CODE

(1)	(2)	(3)	(4)	(5)	(6)	(7)
EV	D2	- 34	/ 2	-	-	-

(1) EV : screw-in directional solenoid valve with Ø 13 mm solenoid core (see 4), 2 way, 2 position

(2) D2 : poppet type, normally closed, BI-directional-control

(3) 34 : cavity 3/4 " 16 UNF

(4) 2: with Ø 15,87 mm nose

(5) 02: filter and manual override

(6) Electric voltage and solenoid coils (see 3, see 6 )

0000: no coil

012C: coil for V12DC

024C: coil for V24DC

220R: coil for V220-230 RAC

(7) Options for coil connection

no designation: standard connection ISO4400/DIN 43650/A

C: flying leads

A: AMP Junior

D: deutsch

(8) Options for ISO4400/DIN 43650/A connectors

B9: standard connector, black PG9

D9: black connector, with diode, PG9

ES: "energy saving" connector with LED

R\*: rectifier bridge

L\*:LED

V\*:LED+varistor

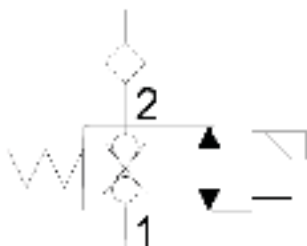
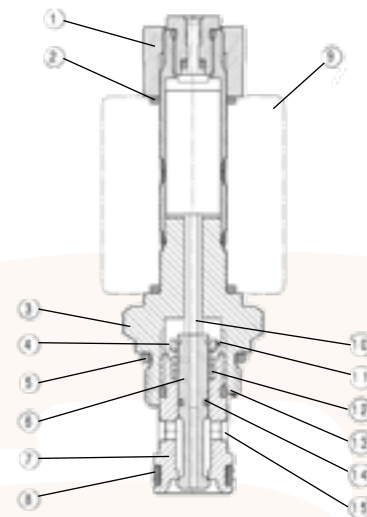
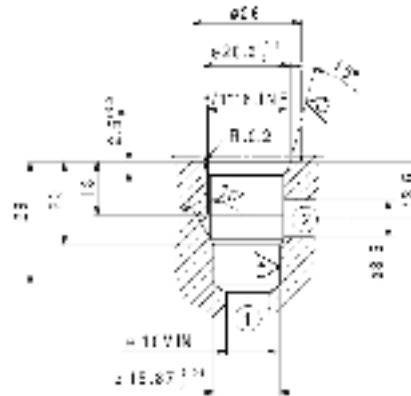

The poppet 6 is balanced by pressure and it is kept normally closed against its seat 7 by spring 12. When the solenoid is energized, the mobile armature moves against spring 12 the poppet 6, thus permitting flow from 2 to 1 and from 1 to 2. The manual override is of the pin type and, when pushed, it permits the valve's operation in case of electric failure. The filter (0,25 mm) on way 2 prevents from dirt and better diffuses the flow around the poppet.

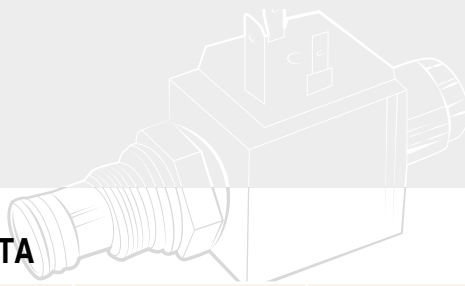

### 3 TECHNICAL DATA

Max. nominal pressure	21 MPa (210 bar)	Electric Characteristics: Those solenoid valves are normally equipped by coils type C36, which are energized from DC or AC supply. Coils type C36-***C are DC energized directly from a V***DC supply. Coils type C36-***R are RAC (Rectified Alternate Current) energized from a V***AC supply, by a full wave bridge rectifier incorporated in the connector. Coils type C36 are normally provided for use of ISO 4400 / DIN 43650/A connectors. For coils with different connection to the power supply, see table C36
Nominal flow rate	16 l/min	
Max. rec. flow rate	25 l/min	
Dimension and installation	see 4	

### 4 INSTALLATION DIMENSIONS (mm)

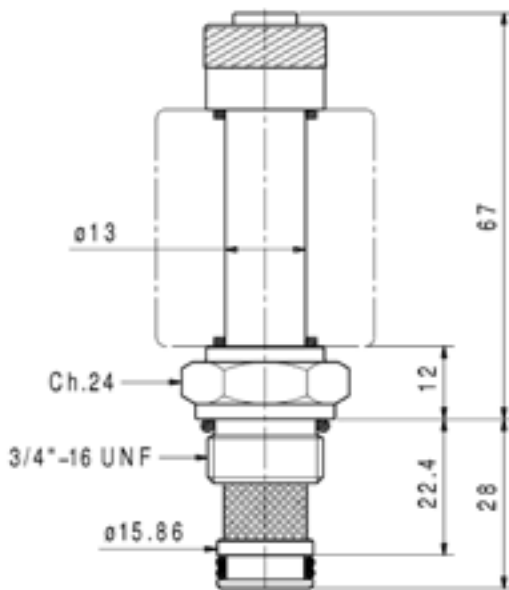

EVD2.34/2 valves are to be installed in cavity 3/4" 16 UNF with Ø 15,87 mm. Check the appropriate state and position of the seals supplied with the valve:

- Dual seal 12,7x1,8x3
- O-ring 16,36x2,20
- 2 x O-ring 13 x 2

Screw the valve in the cavity and lock it with a torque of about 45 Nm applied on the 24mm hexagon.

### 7 CONNECTORS

Standard coils are compatible with KA-132 connectors (see table) ; for some functions (R\*= bridge rectifier. L\*= LED , etc.) the voltage has to be specified :

1 = V12 - V24    2 = V115    3 = V230

The "energy saving" connectors (option ES) save current consumption to less than 50% of the nominal and strongly reduce warming up of the coils.

### 5 PRESSURE DROPS

Measured at 46 cSt and 40°C.

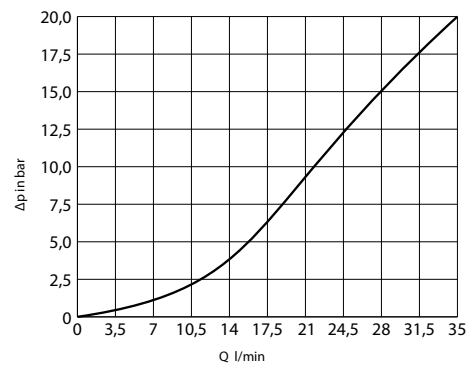

### 6 COILS TYPE C36 ( Ø 13mm)

Coils DIN	voltage DC	nominal current (A)	resistance 20° C (Ω)	nominal power (W)	insulation class
C36-012C	V 12 DC	1,9	6,3	22,8	H
C36-024C	V 24 DC	0,95	25,6	22,5	
C36-024R	V 24 RAC	1,05	20,2	23,0	
C36-048C	V 48 DC	0,47	102	22,6	
C36-110R	V 110-115 RAC	0,23	420	22,9	
C36-220R	V 220-230 RAC	0,11	1720	22,3	

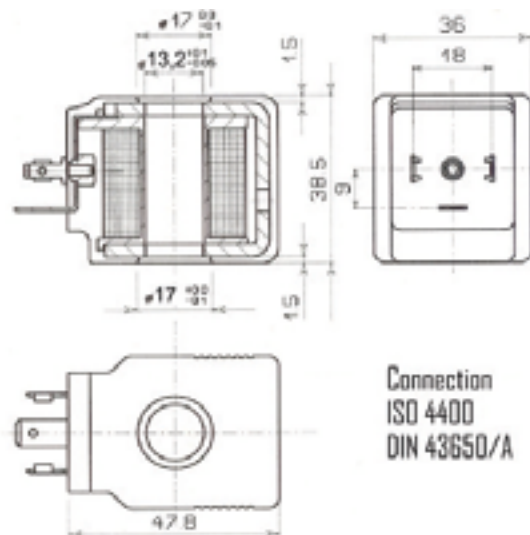

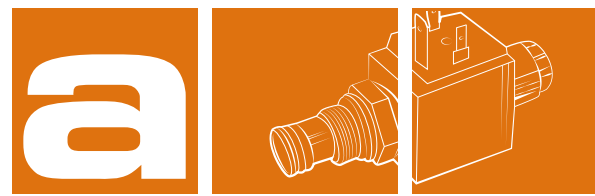

SCREW IN, 2-WAY SOLENOID OPERATED POPPET VALVES NORMALLY OPEN, ONE DIRECTIONAL FLOW  
CAVITY 3/4" 16 UNF Ø 12,7 mm

## EVO.34.

32 l/min 25 MPa (250 bar)

### 1 DESCRIPTION

The valve is a pilot operated 2 way NO poppet type. It is available in different configurations. It is possible to use the valve with standard coils suitable DC or RAC (rectified alternat current) for AC supply.



### 2 ORDERING CODE

(1)	(2)	(3)	(4)	(5)	(6)	(7)
EV	O	- 34	-	-	-	-

(1) EV : screw-in directional solenoid valve

(2) O : valve with Ø 13 mm solenoid core (see 4), 2 way, 2 position, poppet type, normally open, one direction flow

(3) 34 : cavity 3/4 " 16 UNF with Ø 12,7 mm - see A

(4) Valves variants (see 8)

- 03 : without manual override
- 04 : manual override

(5) Electric voltage and solenoid coils(see 3, see 6)

- 0000 : no coil
- 012C : coil for V12DC
- 024C : coil for V24DC
- 220R : coil for V220-230 RAC

(6) Options for coil connection (see 3)

- no designation : standard connection ISO4400/DIN 43650/A
- /C : flying leads
- /A: AMP Junior

(7) Options for ISO4400/DIN 43650/A connectors (see 7)

- B9 : standard connector, black PG9
- D9 : black connector, with diode, PG9
- ES : "energy saving" connector with LED
- R\* : rectifier bridge; L\*:LED; V\*:LED+varistor

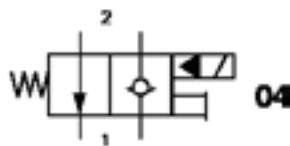
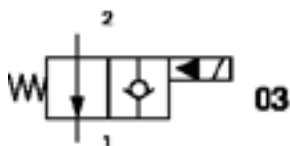
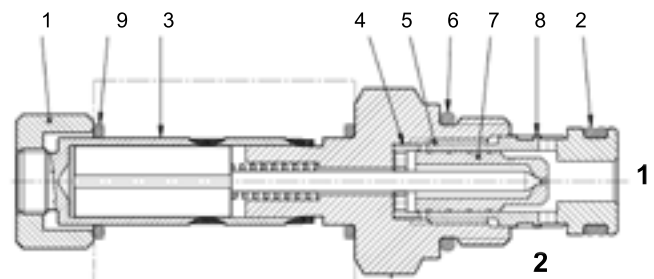
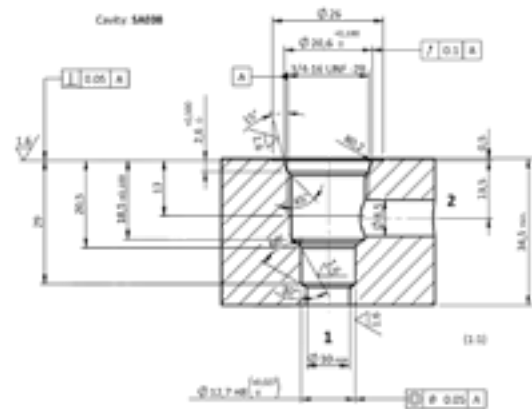

The poppet 4 is pilot operated and it is kept, balanced by pressure, normally open permitting flow from 2 to 1. When the solenoid 6 is energized, the mobile armature 7 and the pilot pin 8 move against the spring and the poppet, closes against its seat 5. The manual override 9, by pushing, permits the valve operation.

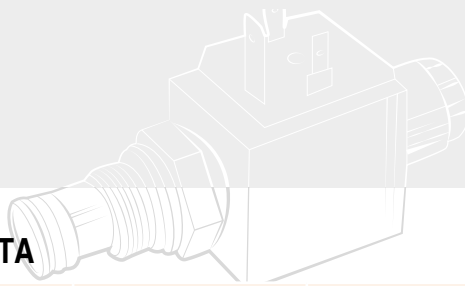

### 3 TECHNICAL DATA

Max. nominal pressure	25 MPa (250 bar)	Electric Characteristics: Those solenoid valves are normally equipped by coils type C30, which are energized from DC or AC supply. Coils type C30-***C are DC energized directly from a V***DC supply. Coils type C30-***R are RAC (Rectified Alternate Current) energized from a V***AC supply, by a full wave bridge rectifier incorporated in the connector. Coils type C30 are normally provided for use of ISO 4400/DIN 43650/A connectors. For coils with different connection to the power supply, see table C30/36.
Nominal flow rate	20 l/min	
Max. rec. flow rate	32 l/min	
Dimension and installation	see 4	
Duty cycle	ED100%	
Mass (without coil)	0,120kg	

### 4 INSTALLATION DIMENSIONS (mm)

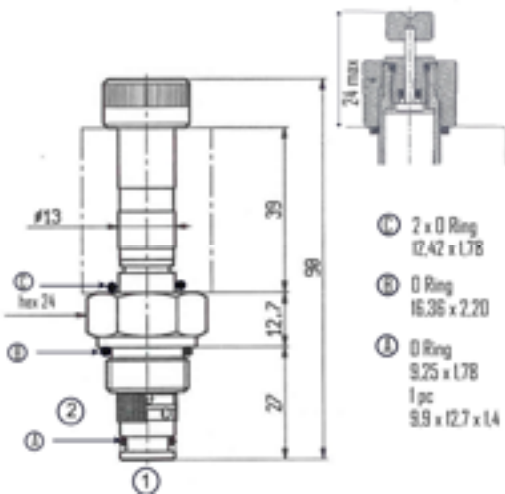

EV\*.34 valves are to be installed in cavity 3/4" 16 UNF with Ø 12,7 mm (see A and 6). Check the appropriate state and position of the seals and , screw the valve in the cavity and lock it with a torque of about 45 Nm applied on the 24 mm hexagon.

### 7 CONNECTORS

Standard coils are compatible with KA-132 connectors ; for some functions (R\* = bridge rectifier, L\* = LED, etc.) the voltage has to be specified :

1 = V12 - V24    2 = V115    3= V230

The "energy saving" connectors – option ES – save current consumption to less than 50% of the nominal and strongly reduce warming up of the coils – see table KA-ES.

### 8 VARIANTS

01 and 02: filter (0,25 mm) on way 2 prevents from dirt and better diffuses the flow around the poppet. 02 and 04 : manual override is of pushing type. Push to pilot the poppet closed (no flow from 1 to 2); pull to reinstall the condition of normally open poppet (flow from 1 to 2).

### 5 PRESSURE DROPS

Viscosity 42 cSt at 50°C.

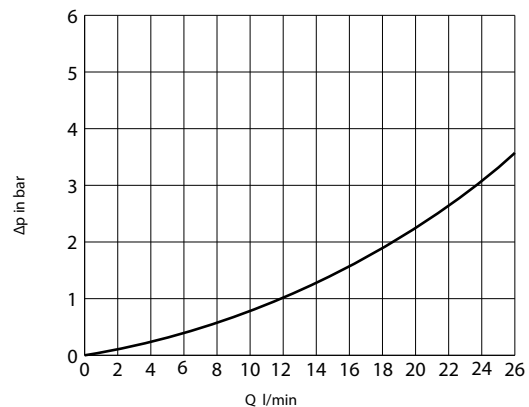

### 6 COILS TYPE C30 ( Ø 13mm-18w)

Coils ISO/DIN	voltage DC/RAC	nominal current (A)	resistance 20° C (Ω)	nominal power (W)	insulation class
C30-012C	V 12 DC	1,55	7,7	18,6	F
C30-024C	V 24 DC	0,8	31	19	
C30-024R	V 24 RAC	0,85	27	18,3	
C30-048C	V 48 DC	0,4	116	19	
C30-48R	V48 RAC	0,4	106	17,3	
C30-110R	V 110-115 RAC	0,16	600	16	
C30-220R	V 220-230 RAC	0,08	2500	16	

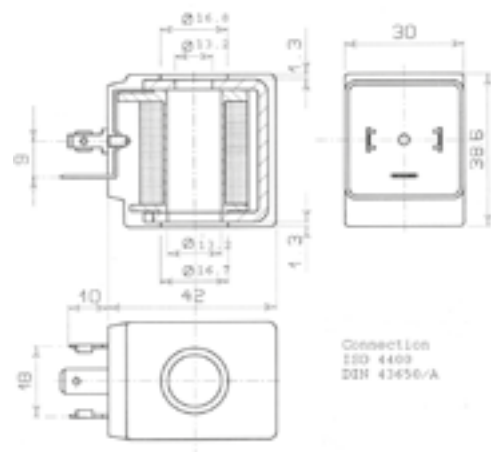

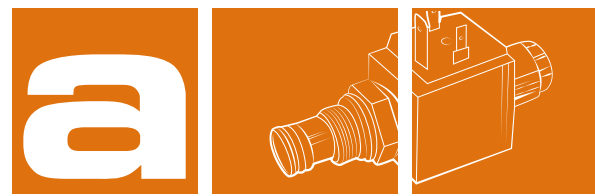

## SCREW IN, 2-WAY SOLENOID OPERATED POPPET VALVES NORMALLY OPEN, BI DIRECTIONAL FLOW CAVITY 3/4" 16 UNF Ø 12,7 mm

### EVO2.34.

40 l/min 25 MPa (250 bar)

#### 1 DESCRIPTION

The valve is a pilot operated 2 way NO poppet type. It is available in different configurations. It is possible to use the valve with standard coils suitable DC or RAC (rectified alternat current) for AC supply.

A special dual seal ring on the nose permits an efficient and reliable sealing system.

#### 2 ORDERING CODE

(1)	(2)	(3)	(4)	(5)	(6)	(7)
EV	O2	- 34	-	-	-	-

(1)EV : screw-in directional solenoid valve

(2) O2 : valve with Ø 13 mm solenoid core (see 4), 2 way, 2 position, poppet type, normally open, two direction flow

(3) 34 : cavity 3/4 " 16 UNF with Ø 12,7 mm - see A

(4) Valves variants (see 8)  
 02 : filter and manual override  
 03 : without manual override  
 04 : manual override

(5) Electric voltage and solenoid coils(see 3, see 6)  
 0000 : no coil  
 012C : coil for V12DC  
 024C : coil for V24DC  
 220R : coil for V220-230 RAC

(6) Options for coil connection (see 3)  
 no designation : standard connection ISO4400/DIN 43650/A  
 C : flying leads  
 A: AMP Junior

(7) Options for ISO4400/DIN 43650/A connectors (see 7)  
 B9 : standard connector, black PG9  
 D9 : black connector, with diode, PG9  
 ES : "energy saving" connector with LED  
 R\* : rectifier bridge; L\*:LED; V\*:LED+varistor

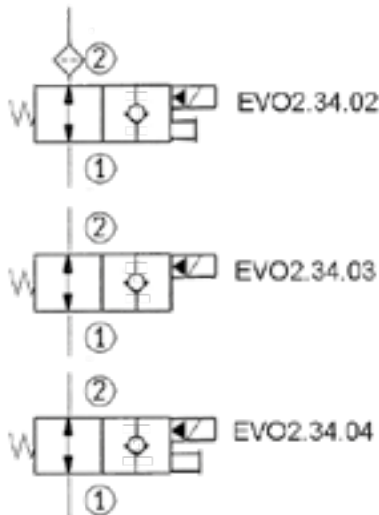
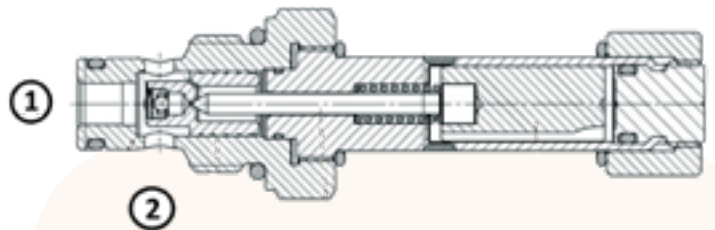
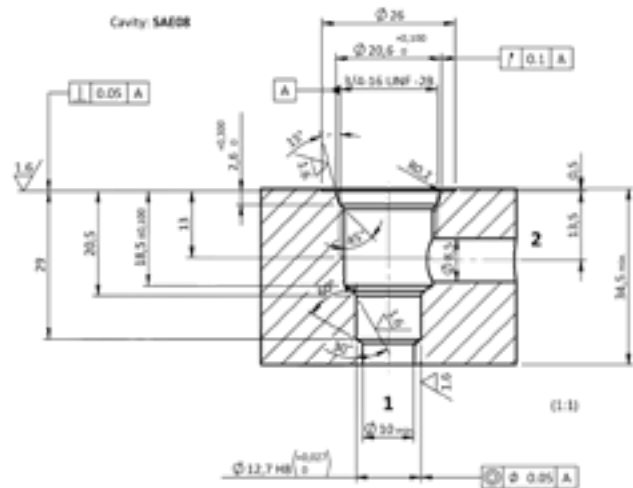

The poppet 4 is pilot operated and it is kept, balanced by pressure, normally open permitting flow from 2 to 1. When the solenoid 6 is energized, the mobile armature 7 and the pilot pin 8 move against the spring and the poppet, closes against its seat 5. The manual override 9, by pushing, permits the valve operation.

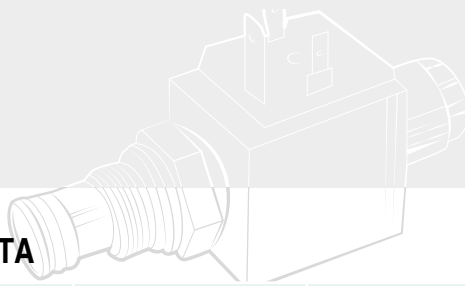

### 3 TECHNICAL DATA

Max. nominal pressure	32 MPa (320 bar)	Electric Characteristics: Those solenoid valves are normally equipped by coils type C30, which are energized from DC or AC supply (see 6). Coils type C30-***C are DC energized directly from a V***DC supply. Coils type C30-***R are RAC (Rectified Alternate Current) energized from a V***AC supply, by a full wave bridge rectifier incorporated in the connector. Coils type C30 are normally provided for use of ISO 4400/DIN 43650/A connectors. For coils with different connection to the power supply, see table C30/36.
Nominal flow rate	32 l/min	
Max. rec. flow rate	40 l/min	
Dimension and installation	see 4	
Duty cycle	ED100%	
Massb (without coil)	0,120kg	

### 4 INSTALLATION DIMENSIONS (mm)

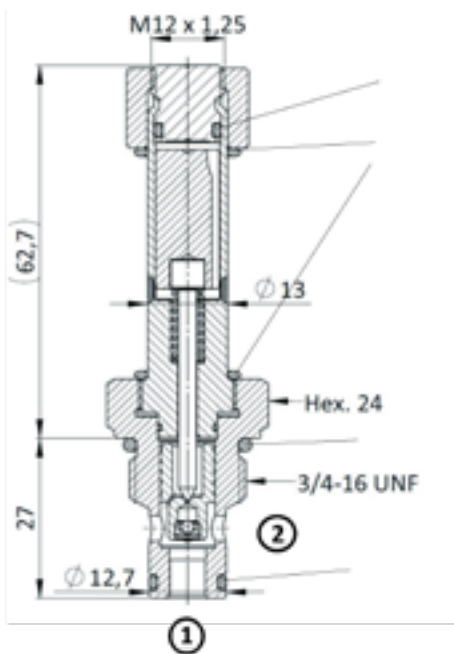

EV\*.34 valves are to be installed in cavity 3/4" 16 UNF with Ø 12,7 mm. Check the appropriate state and position of the seals and , screw the valve in the cavity and lock it with a torque of about 45 Nm applied on the 24 mm hexagon.

### 7 CONNECTORS

Standard coils are compatible with KA-132 connectors (see table) ; for some functions (R\* = bridge rectifier, L\* = LED, etc.) the voltage has to be specified :

1 = V12                      V24 2 = V115                      3 = V230

The "energy saving" connectors – option ES – save current consumption to less than 50% of the nominal and strongly reduce warming up of the coils – see table KA-ES.

### 8 VARIANTS

01 and 02 : filter (0,25 mm) on way prevents from dirt and better diffuses the flow around the poppet. 02 and 04 : manual override is of pushing type. Push to pilot the poppet closed (no flow from to ); pull to reinstall the condition of normally open poppet (flow from to ).

### 5 PRESSURE DROPS

Viscosity 42 cSt at 50°C.

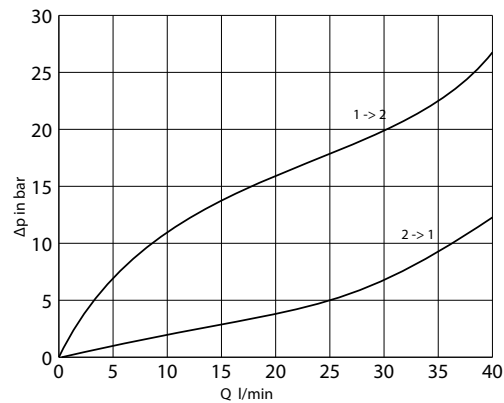

### 6 COILS TYPE C30 ( Ø 13mm-18w)

Coils ISO/DIN	voltage DC/RAC	nominal current (A)	resistance 20° C (Ω)	nominal power (W)	insulation class
C30-012C	V 12 DC	1,55	7,7	18,6	F
C30-024C	V 24 DC	0,8	31	19	
C30-024R	V 24 RAC	0,85	27	18,3	
C30-048C	V 48 DC	0,4	116	19	
C30-48R	V48 RAC	0,4	106	17,3	
C30-110R	V 110-115 RAC	0,16	600	16	
C30-220R	V 220-230 RAC	0,08	2500	16	

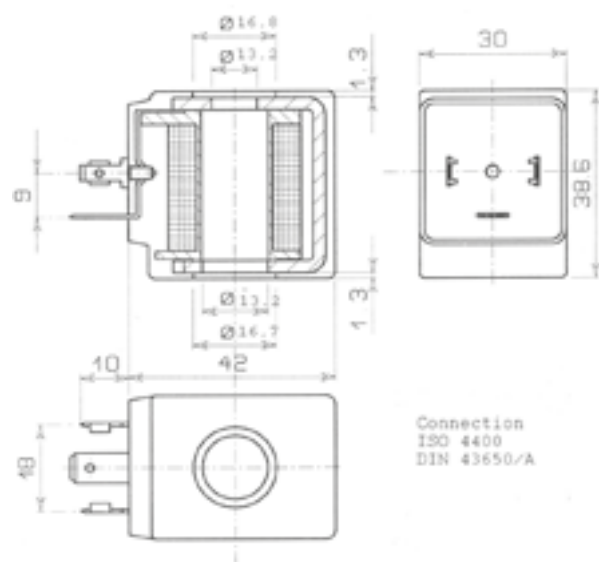

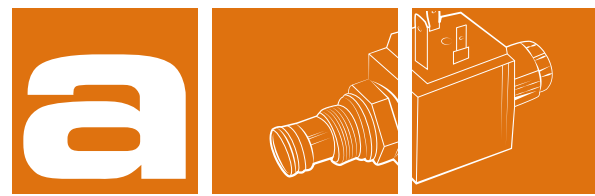

### SCREW IN, 2-WAY SOLENOID OPERATED SPOOL TYPE DIRECTIONAL VALVES

CAVITY 3/4" 16 UNF- SAE 08/2

**EV\*2\*.34.\***

20 l/min 25 MPa (250 bar)

## 1 DESCRIPTION

Directional control valve 2 way 2 position spool type. Is possible to have this valve in two different version, light line and high performance.

Light line version is available with plastic coils and metallic coils.

High performance version is available only with metallic coils.

The dual seals rings assure an efficient and reliable tightness of the valve.



## 2 ORDERING CODE

(1)	(2)	(3)	(4)	(5)	(6)	(7)	(8)	(9)
EV		2		-	34			

(1) EV: solenoid operated valve

(2) valve type

L: Light line

H: High performance

(3) two way valve

(4) Spool type

C: normally closed

O: normally open

(5) 34: cavity 3/4" UNF (SAE 08/2)

(6) Valves variants (see 6)

03: without manual override

04: manual override push type (standard)

05: manual override screw type

(7) Electric voltage and solenoid coils (see 3, see 8)

0000: no coil

012C: coil for V12DC

024C: coil for V24DC

220R: coil for V220-230 RAC

(8) Option for coils connection (see 8)

no designation: standard connection ISO 4400 / DIN 43650/A

/C: flying leads;

/D: Deutsch;

/A: AMP Junior

(9) options for ISO 4400 / DIN 43650/A connectors (see 7)

B9: standard connector, black PG9

D9: black connector, with diode, PG9

ES: "energy saving" connector with LED

R\*: rectifier bridge;

L\*:LED;

V\*:LED+varistor

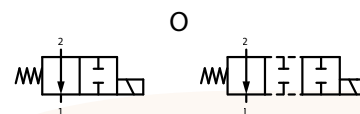
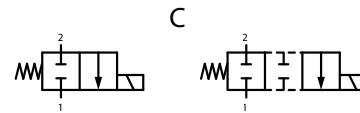
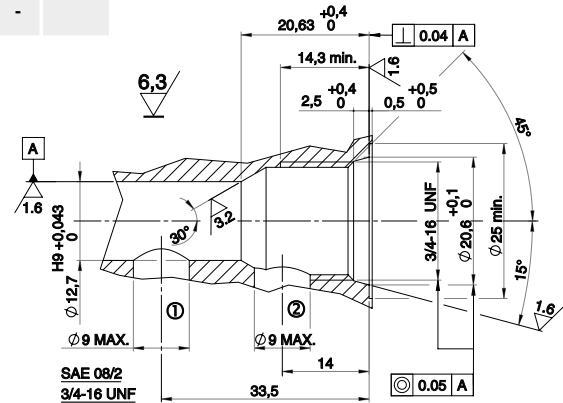

Screw-in 2/2 solenoid valves type EV2\*.34 are composed by a valve sleeve 1, a control spool 2, a return spring 3, and an actuating assembly 4 that comprises the magnetic parts and the screwing section. An energizing electric solenoid coil 5 is fastened to the assembly by means of a retaining nut 6. When solenoid coils is energized, a magnetic mobile armature shifts and by means of a rod installed inside assembly, moves the control spool which makes hydraulic connections between 1,2 ports.

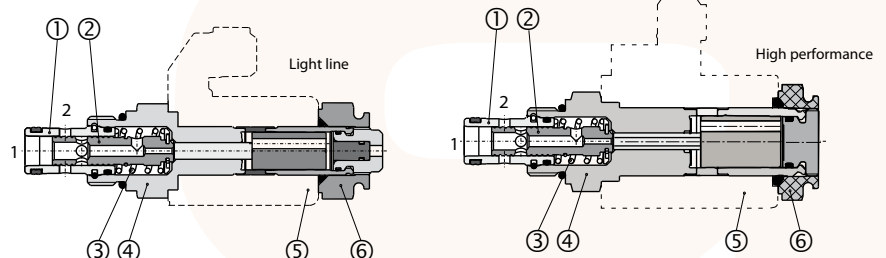



### 3 TECHNICAL DATA

Max. nominal pressure	25 MPa (250 bar)	Electric Characteristics: Those solenoid valves are normally equipped by coils type C36, which are energized from DC or AC supply. Coils type C36-***C are DC energized directly from a V***DC supply. Coils type C36-***R are RAC (Rectified Alternate Current) energized from a V***AC supply, by a full wave bridge rectifier incorporated in the connector. Coils type C36 are normally provided for use of ISO 4400/DIN 43650/A connectors. For coils with different connection to the power supply, see table C30/36.
Nominal flow rate	16 l/min	
Max. rec. flow rate	20 l/min	
Dimension and installation	(see 4)	
Duty cycle	ED100%	
Massb (without coil)	0,20 kg	

### 4 INSTALLATION DIMENSIONS (mm)

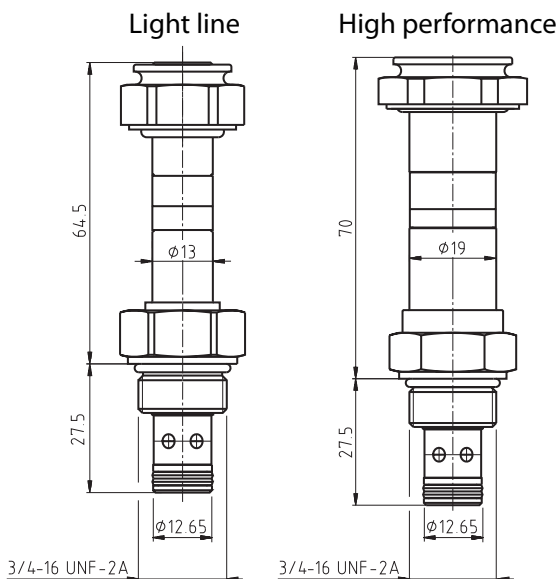

#### SEALS:

#### BODY:

- 1 pcs Dualseal-PU 10,3x12,7x3,1
- 1 pcs O-ring-NBR 17,0x1,8

#### SOLENOID AND RETAINING NUT:

- 1 pcs O-ring-NBR 12,3x2,4
- 1 pcs O-ring-Viton 20x2,5

EV2\*.34 valves are to be installed in cavity 3/4" 16 UNF. Check the appropriate state and position of the seals, screw the valve in the cavity and lock it with a torque of about 45 Nm applied on the 24 mm hexagon.

### 6 VARIANTS OF MANUAL OVERRIDE

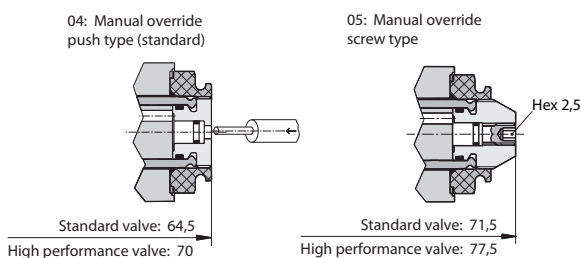

### 5 TYPICAL DIAGRAMS

Light line and High performance valve

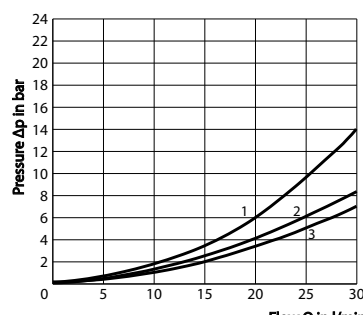

- 1 Normally closed (C) 1→2
- 2 Normally open (O) 1→2
- 3 Normally open (O) 2→1

Hydraulic limits of use Light line valve

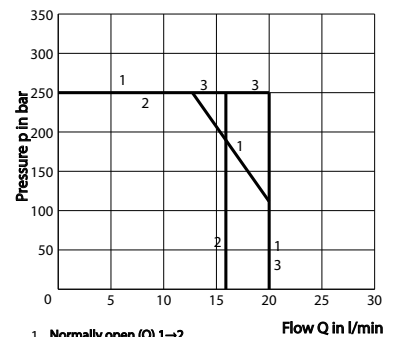

- 1 Normally open (O) 1→2
- 2 Normally closed (C) 2→1
- 3 Normally open (O) 2→1

Hydraulic limits of use High performance valve

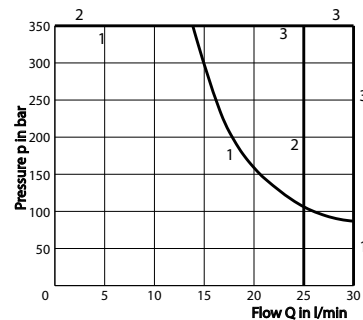

- 1 Normally open (O) 1→2
- 2 Normally closed (C) 2→1

### 7 CONNECTORS

Standard coils are compatible with KA-132 connectors (see table) ; for some functions (R\*= bridge rectifier, L\*= LED, etc.) the voltage has to be specified :

1 = V12 V24                      2 = V115                      3 = V230

The "energy saving" connectors – option ES – save current consumption to less than 50% of the nominal and strongly reduce warming up of the coils.

## 8 COILS type C36L (Ø 13 mm)

Coils DIN	voltage DC	nominal current (A)	resistance 20° C (Ω)	nominal power (W)	insulation class
C36L-012C	V 12 DC	1,9	6,3	22,8	H
C36L-024C	V 24 DC	0,95	25,6	22,5	
C36L-024R	V 24 RAC	1,05	20,2	23	
C36L-048C	V 48 DC	0,47	102	22,6	
C36L-110R	V 110-115 RAC	0,23	420	22,9	
C36L-220R	V 220-230 RAC	0,11	1720	22,3	

## CONNECTION OPTIONS

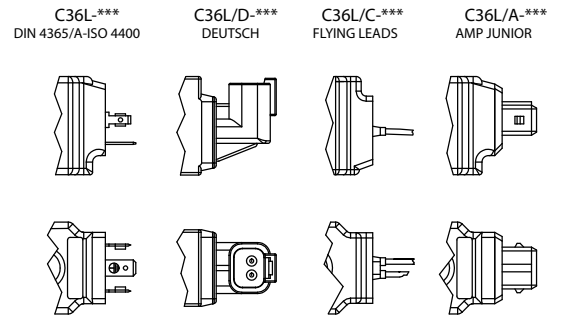

### C36L

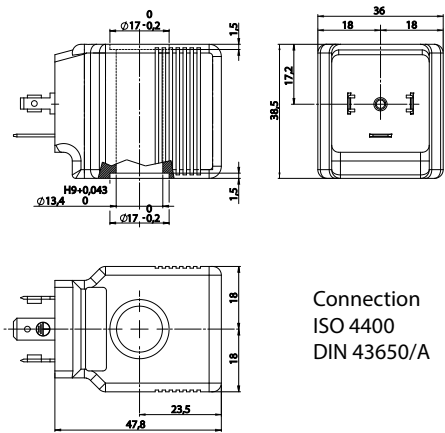

### B01

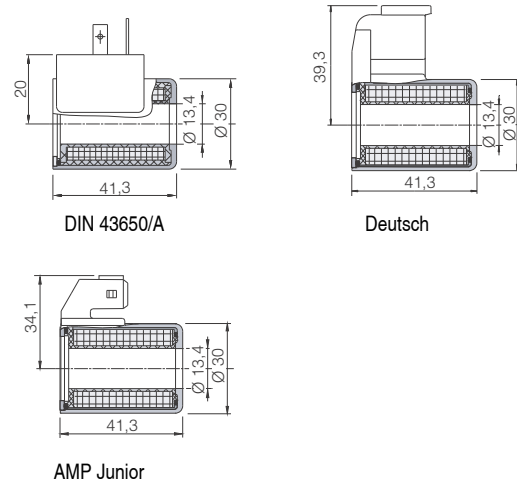

## 9 LINE ASSEMBLY BODY

LINE ASSEMBLY BODY	PORTS	MATERIAL	MASS
LAB-34-2/38	3/8" BSP	Aluminium Alloy	0,25 kg

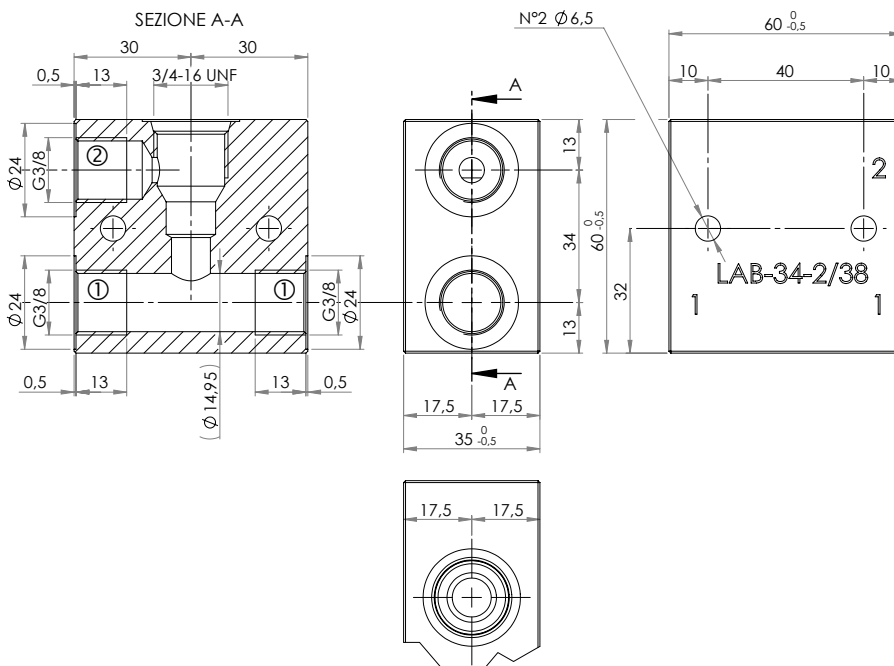

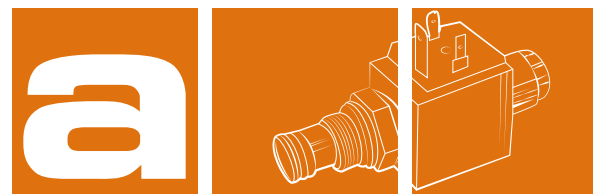

## SCREW IN, 3-WAY SOLENOID OPERATED DIRECTIONAL VALVE CAVITY 3/4" 16 UNF-SAE 08/3

### EV3\*.34.\*

20 l/min 25 MPa (250 bar)

## 1 DESCRIPTION

Directional control valve 3 way 2 position spool type.  
Is possible to have this valve in two different version, light line and high performance.  
Light line version is available with plastic coils and metallic coils.  
High performance version is available only with metallic coils.  
The dual seals rings assure an efficient and reliable tightness of the valve.



## 2 ORDERING CODE

(1)	(2)	(3)	(4)	(5)	(6)	(7)	(8)	(9)
EV		3	-	34	-	-	-	-

(1) EV : 3-way solenoid operated spool type

(2) valve type  
L: Light line  
H: High performance

(3) three way valve

(4) Spool type  
C: normally closed  
O: normally open

(5) 34: cavity 3/4" 16 UNF

(6) Valves variants (see 6)  
03: without manual override  
04: manual override push type (standard)  
05: manual override screw type

(7) Electric voltage and solenoid coils (see 3, see 8)  
0000 : no coil  
012C : coil for V12DC  
024C : coil for V24DC  
220R : coil for V220-230 RAC

(8) Options for coil connection (see 8)  
no designation : standard connection ISO4400/DIN43650/A  
C flying leads  
D:Deutsch  
A: AMP Junior

(9) Options for ISO4400/DIN 43650/A connectors (see 7)  
B9: standard connector, black PG9  
D9: black connector, with diode, PG9  
ES: "energy saving" connector with LED  
R\*: rectifier bridge; L\*:LED; V\*:LED+varistor

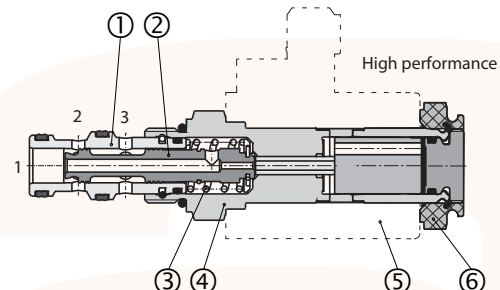
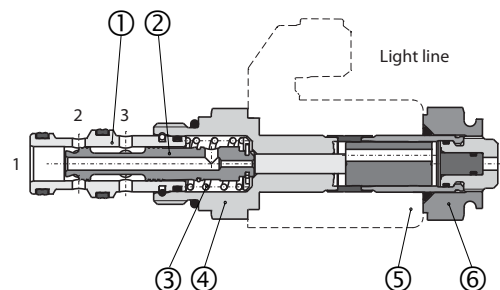
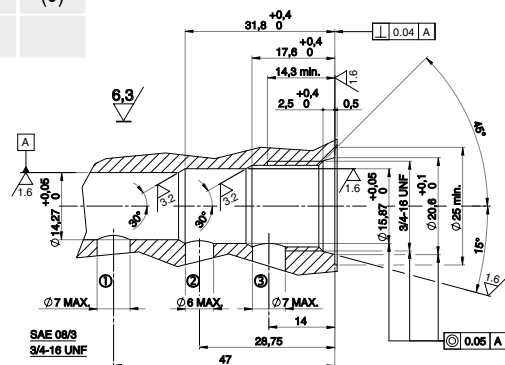
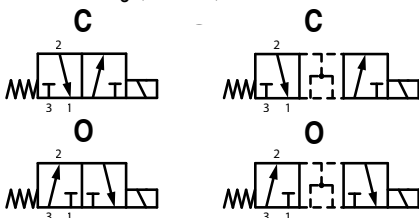

Screw-in 3/2 solenoid valves type EV3\*.34 are composed by a valve sleeve 1, a control spool 2, a return spring 3, and an actuating assembly 4 that comprises the magnetic parts and the screwing section. An energizing electric solenoid coil 5 is fastened to the assembly by means of a retaining nut 6. When solenoid coils is energized, a magnetic mobile armature shifts and by means of a rod installed inside assembly, moves the control spool which makes hydraulic connections between 1,2,3 ports.

## 3 TECHNICAL DATA

Max. nominal pressure	25 MPa (250 bar)	Electric Characteristics:
Nominal flow rate	16 l/min	Those solenoid valves are normally equipped by coils type C36, which are energized from DC or AC supply. Coils type C36-***C are DC energized directly from a V***DC supply. Coils type C36-***R are RAC (Rectified Alternate Current) energized from a V***AC supply, by a full wave bridge rectifier incorporated in the connector. Coils type C36 are normally provided for use of ISO 4400/DIN 43650/A connectors. For coils with different connection to the power supply, see table C30/36.
Max. rec. flow rate	20 l/min	
Dimension and installation	see 4	
Duty cycle	ED100%	
Mass (without coil)	0,20 kg	

## 4 INSTALLATION DIMENSIONS (mm)

Light line

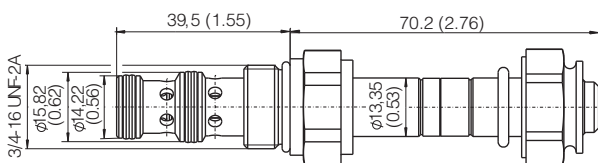

High performance

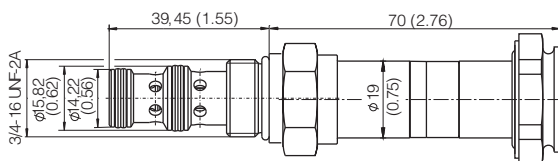

EV3\*.34 valves are to be installed in cavity 3/4" 16 UNF. Check the appropriate state and position of the seals, screw the valve in the cavity and lock it with a torque of about 45 Nm applied on the 24 mm hexagon.

## 5 TYPICAL DIAGRAMS

Hydraulic limits of use High performance valve

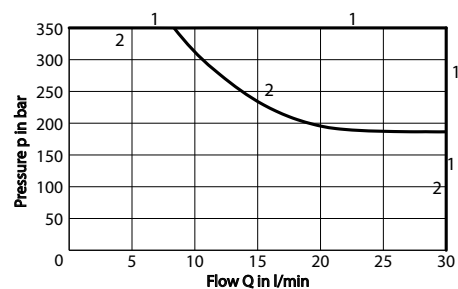

1 Normally closed (C) 3→2  
Normally closed (C) 2→1

2 Normally open (O) 2→1  
Normally open (O) 3→2

Hydraulic limits of use Light line valve

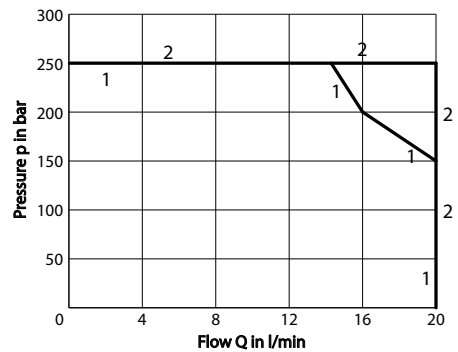

1 Normally open (O) 3→2

2 Normally open (O) 2→1  
Normally closed (C) 2→1  
Normally closed (C) 3→2

## 6 VARIANTS OF MANUAL OVERRIDE

04: Manual override push type (standard)

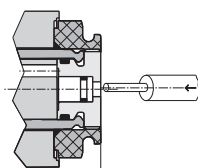

Standard valve: 64,5  
High performance valve: 70

05: Manual override screw type

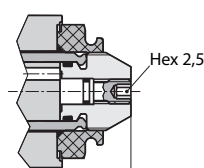

Standard valve: 71,5  
High performance valve: 77,5

## 7 CONNECTORS

Standard coils are compatible with KA-132 connectors (see table); for some functions (R\* = bridge rectifier, L\* = LED, etc.) the voltage has to be specified :

1 = V12, V24      2 = V115      3 = V230

The "energy saving" connectors – option ES – save current consumption to less than 50% of the nominal and strongly reduce warming up of the coils.

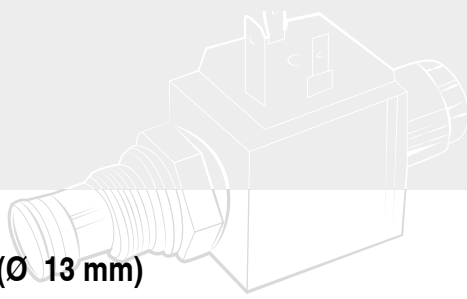

## 8 COILS type C36 (Ø 13 mm)

### CONNECTION OPTIONS

Coils DIN	voltage DC	nominal current (A)	resistance 20° C (Ω)	nominal power (W)	insulation class
C36-012C	V 12 DC	1,9	6,3	22,8	H
C36-024C	V 24 DC	0,95	25,6	22,5	
C36-024R	V 24 RAC	1,05	20,2	23	
C36-048C	V 48 DC	0,47	102	22,6	
C36-110R	V 110-115 RAC	0,23	420	22,9	
C36-220R	V 220-230 RAC	0,11	1720	22,3	

C36L-\*\*\*  
DIN 4365/A-ISO 4400

C36L/D-\*\*\*  
DEUTSCH

C36L/C-\*\*\*  
FLYING LEADS

C36L/A-\*\*\*  
AMP JUNIOR

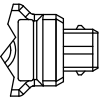
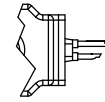
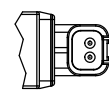
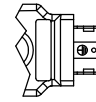
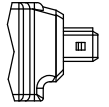
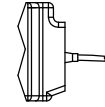
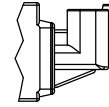
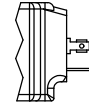

### C36L

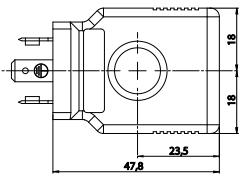
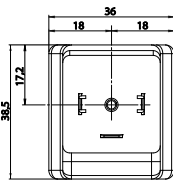
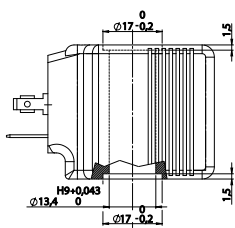

Connection  
ISO 4400  
DIN 43650/A

### B01

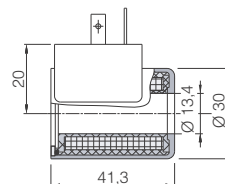

DIN 43650/A

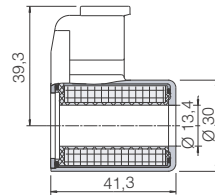

Deutsch

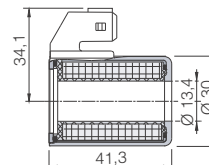

AMP JUNIOR

## 9 LINE ASSEMBLY BODY

LINE ASSEMBLY BODY	PORTS	MATERIAL	MASS
LAB-34-3/38	3/8" BSP	Aluminium Alloy	0,48 kg

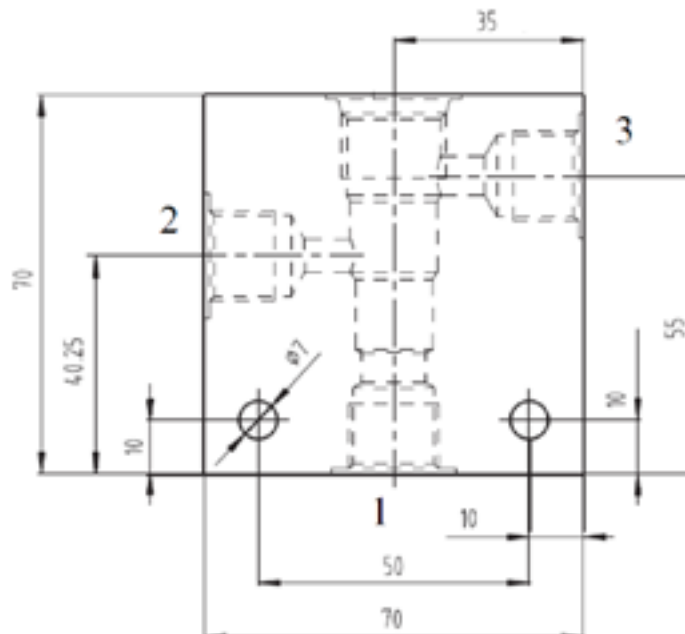
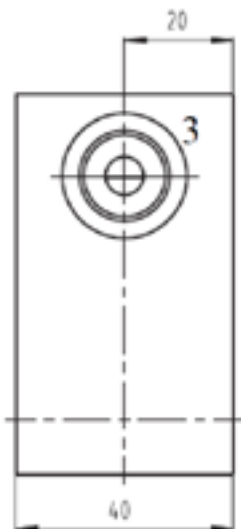



**SCREW IN, 2-WAY SOLENOID OPERATED DIRECTIONAL VALVES  
CAVITY 3/4" 16 UNF- SAE 08/4  
EV4\*\* .34.\*  
20 l/min 25 MPa (250 bar)**

## 1 DESCRIPTION

Directional control valve 4 way 2 position spool type. It is possible to have this valve in two different versions, light line and high performance. Light line version is available with plastic coils and metallic coils. High performance version is available only with metallic coils. The dual seals rings assure an efficient and reliable tightness of the valve.



## 2 ORDERING CODE

(1)	(2)	(3)	(4)	(5)	(6)	(7)	(8)	(9)
EV		4	-	34	-	-	-	-

(1) EV4 : 4-way solenoid operated spool type

(2) valve type  
L: Light line  
H: High performance

(3) four way valve

(4) Spool type  
XP  
PX  
CX  
CP

(5) 34: cavity 3/4" 16 UNF

(6) Valves variants (see 5)  
03 : without manual override  
04 : manual override push type (standard)  
05 : manual override screw type

(7) Electric voltage and solenoid coils (see 8)  
0000 : no coil  
012C : coil for V12DC  
024C : coil for V24DC  
220R : coil for V220-230 RAC

(8) Options for coil connection (see 8)  
no designation: standard connection ISO4400/DIN43650/A  
C: flying leads  
D: Deutsch  
A: AMP Junior

(9) Options for ISO4400/DIN 43650/A connectors (see 7)  
B9 : standard connector, black PG9  
D9 : black connector, with diode, PG9  
ES : "energy saving" connector with LED  
R\* : rectifier bridge; L\*:LED; V\*:LED+varistor

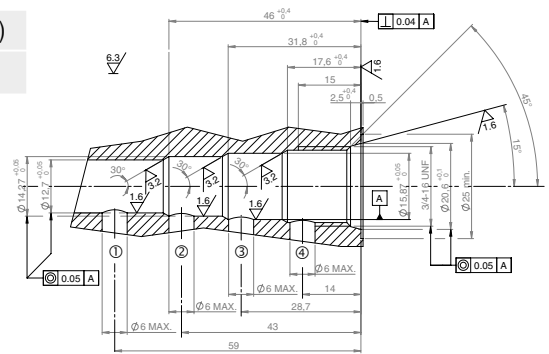

Light line

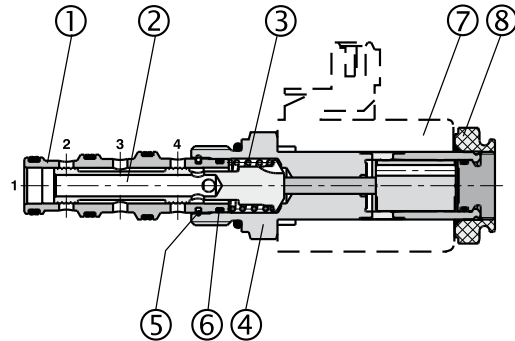

High performance

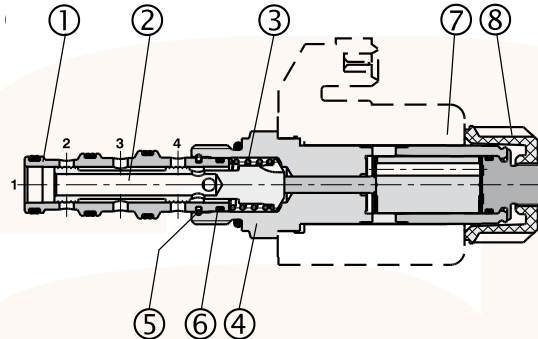

Screw-in 4/2 solenoid valves type EV4\*\* .34 are composed by a valve sleeve 1, a control spool 2, a return spring 3, and an actuating assembly 4 that comprises the magnetic parts and the screwing section. An energizing electric solenoid coil 5 is fastened to the assembly by means of a retaining nut 6. When solenoid coils is energized, a magnetic mobile armature shifts and by means of a rod installed inside assembly, moves the control spool which makes hydraulic connections between 1, 2, 3, 4 ports.

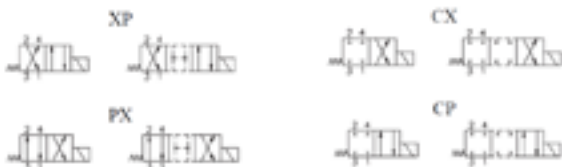

3-P: 1-T 2-A: 4-B

### 3 TECHNICAL DATA

Max. nominal pressure	25 MPa (250 bar)	Electric Characteristics: Those solenoid valves are normally equipped by coils type C36, which are energized from DC or AC supply. Coils type C36-***C are DC energized directly from a V***DC supply. Coils type C36-***R are RAC (Rectified Alternate Current) energized from a V***AC supply, by a full wave bridge rectifier incorporated in the connector. Coils type C36 are normally provided for use of ISO 4400/DIN 43650/A connectors. For coils with different connection to the power supply, see table C30/36.
Nominal flow rate	16 l/min	
Max. rec. flow rate	20 l/min	
Dimension and installation	see 4	
Duty cycle	ED100%	
Mass (without coil)	0,20 kg	

### 4 INSTALLATION DIMENSIONS (mm)

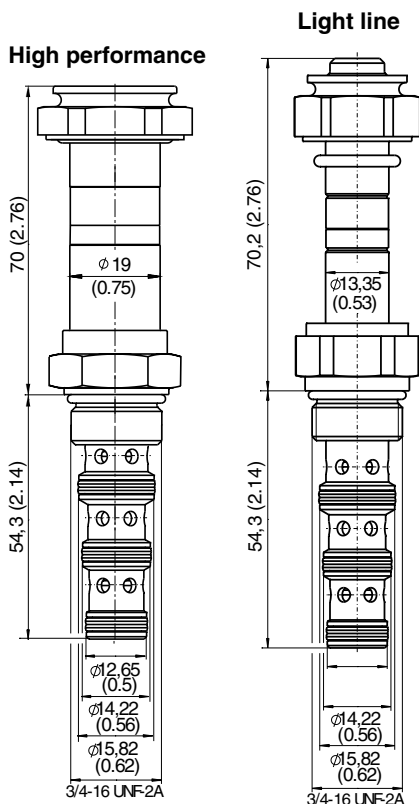

### 5 TYPICAL DIAGRAMS

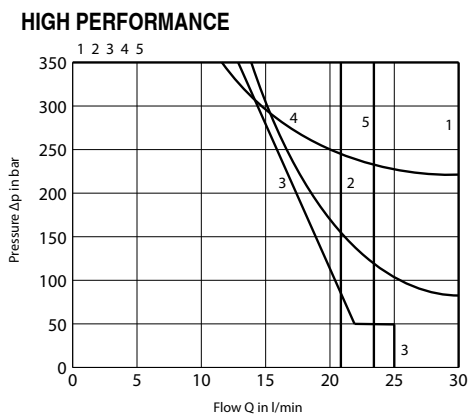
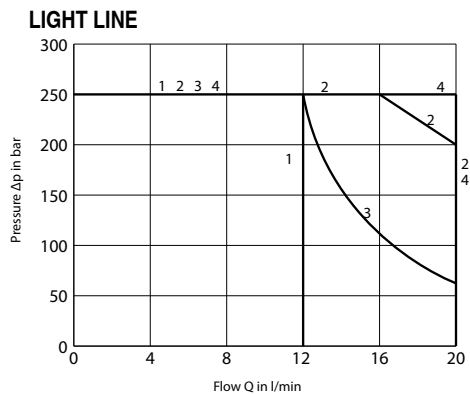

EV4\*.34 valves are to be installed in cavity 3/4" 16 UNF. Check the appropriate state and position of the seals, screw the valve in the cavity and lock it with a torque of about 45 Nm applied on the 24 mm hexagon.

### 6 VARIANTS OF MANUAL OVERRIDE

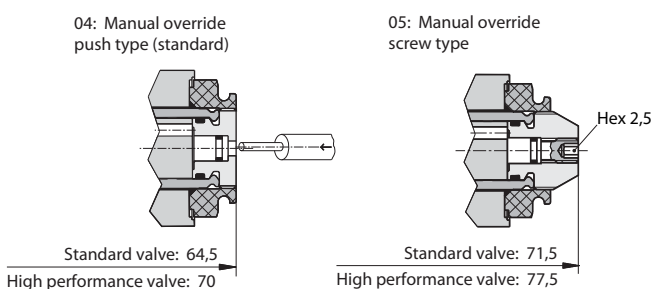

### 7 CONNECTORS

Standard coils are compatible with KA-132 connectors; for some functions (R\* = bridge rectifier, L\* = LED, etc.) the voltage has to be specified :

1 = V12 V24      2 = V115      3 = V230

The "energy saving" connectors – option ES – save current consumption to less than 50% of the nominal and strongly reduce warming up of the coils.

## 8 COILS type C36 (Ø 13 mm)

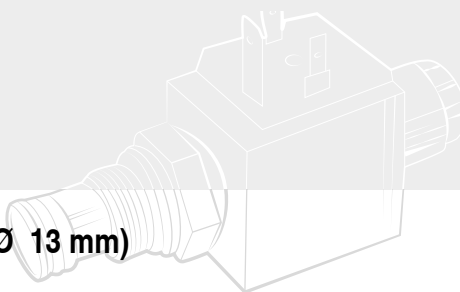

### CONNECTION OPTIONS

Coils DIN	voltage DC	nominal current (A)	resistance 20° C (Ω)	nominal power (W)	insulation class
C36-012C	V 12 DC	1,9	6,3	22,8	H
C36-024C	V 24 DC	0,95	25,6	22,5	
C36-024R	V 24 RAC	1,05	20,2	23	
C36-048C	V 48 DC	0,47	102	22,6	
C36-110R	V 110-115 RAC	0,23	420	22,9	
C36-220R	V 220-230 RAC	0,11	1720	22,3	

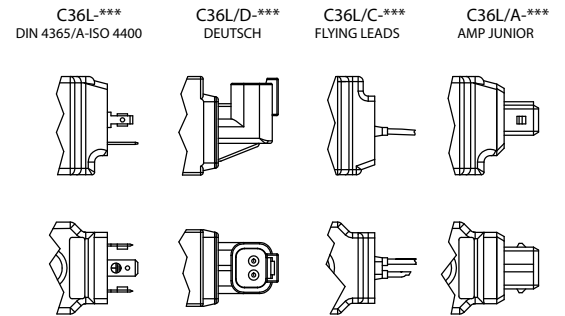

### C36L

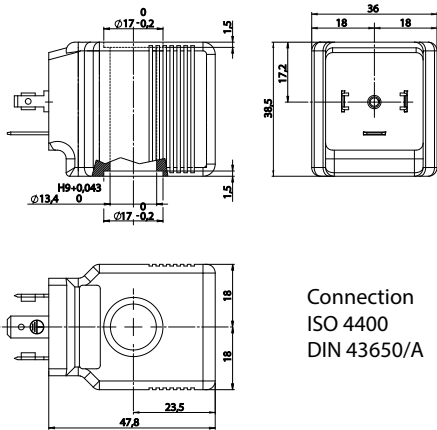

### B01

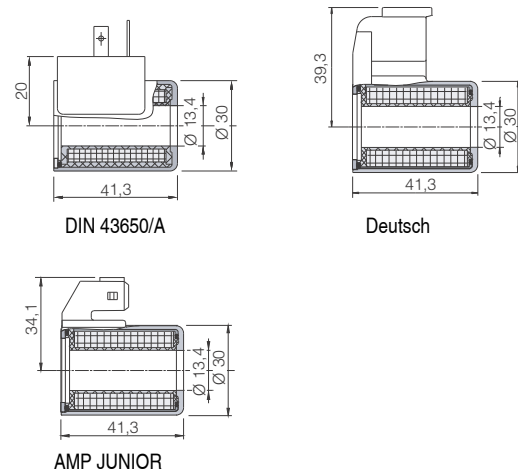

## 9 LINE ASSEMBLY BODY

LINE ASSEMBLY BODY	PORTS	MATERIAL	MASS
LAB-34-4/38	3/8" BSP	Aluminium Alloy	0,54 kg

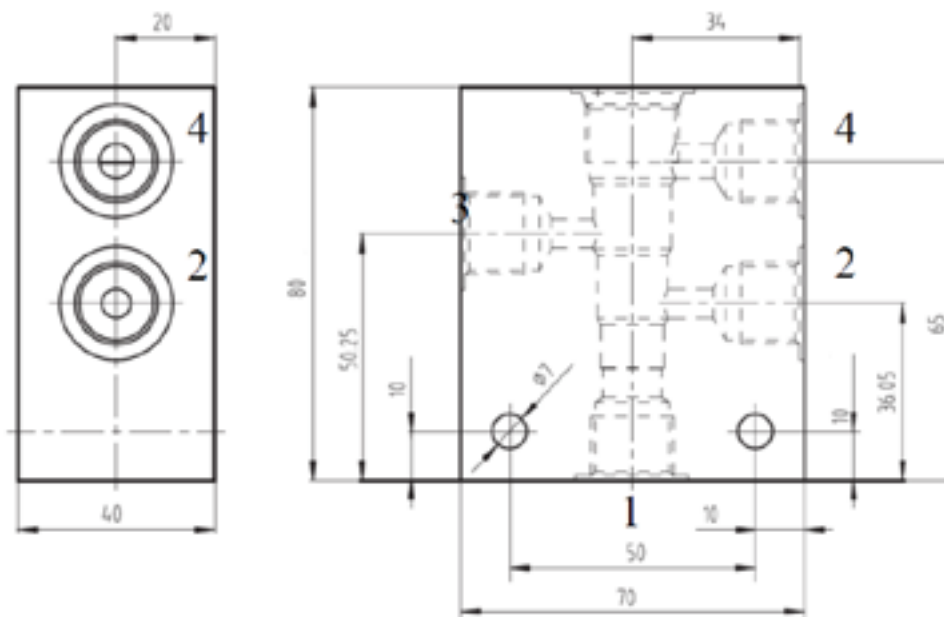



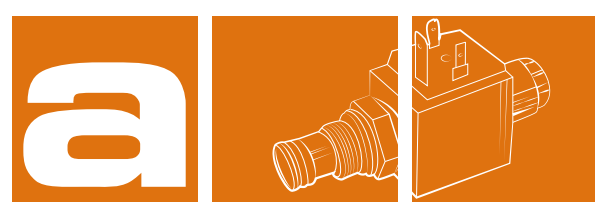

## 30 mm COIL SERIES

### C30 COILS

Ø 13 mm-18 w; 35 VA

#### 1 DESCRIPTION

- Magnetic circuit encapsulated with fibre-glass reinforced nylon.
- Standard colour black.
- Metallic parts protected against oxidation.

#### 2 ORDERING CODE

(1)	(2)	(3)
C30	-	-

C30-\*\*\*\* : DIN 43650/A  
 C30/C-\*\*\*\* : flying leads  
 C30/K-\*\*\*\* : kostal M24x1  
 C30/A-\*\*\*\* : AMP Junior

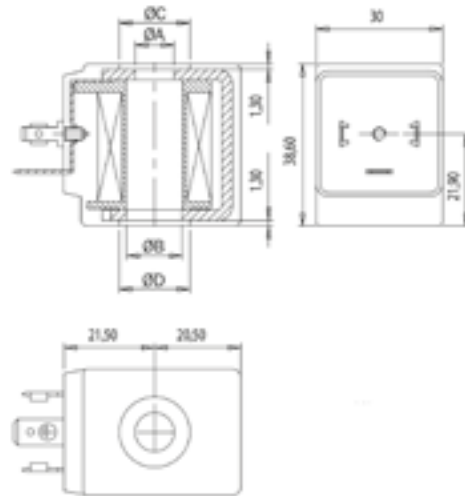

#### 3 TECHNICAL DATA

Typical nominal voltages	- 12-24VDC - 24-110-220VAC and RAC
Class F coil as from the IEC	85 standard
Class H wire	200°C
Duty cycle	ED 100% code, voltages, currents and power consumption.
see table for coils:	012C, 024C, 048C for VDC 024R, 110R, 220R for RAC (rectified alternate current)
Frequency	024/50, 110/50, 230/50 for AC at 50Hz 110/60, 220/60 for AC at 60Hz

Coil with ISO/DIN connector	voltage DC	nominal current (A)	resistance cold ( )	nominal power (W)	insulation class
C30-012C	V 12 DC	1,55	7,7	18,6	F
C30-024C	V 24 DC	0,8	31	19	
C30-024R	V 24 RAC	0,85	27	18,3	
C30-048C	V 48 DC	0,4	116	19	
C30-048R	V 48 RAC	0,4	106	17,3	
C30-110R	V 110-115 RAC	0,16	600	16	
C30-220R	V 220-230 RAC	0,08	2500	16	
	AC	(*)		(VA) (*)	F
C30-024/50	24V 50Hz	0,9	5,3	35	
C30-110/50	110-115V 50Hz	0,2	108		
C30-230/50	220-230V 50Hz	0,1	438		
C30-110/60	110-115V 60Hz	0,3	92		
C30-220/60	220-230V 60Hz	0,15	375		

DIN 4365/A-ISO 4400      DEUTSCH      FLYING LEADS      AMP JUNIOR

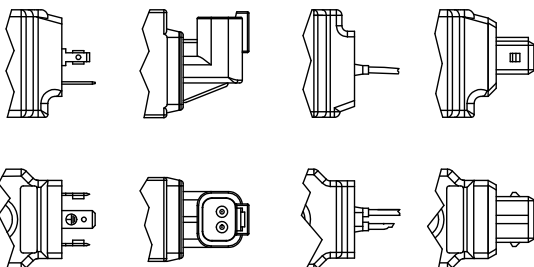

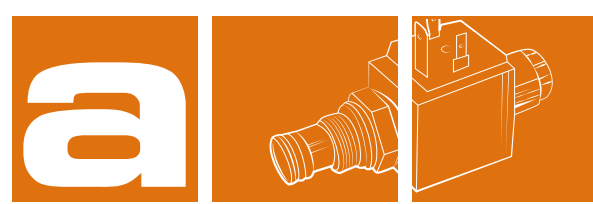

### 36 mm COIL SERIES

## C36 COILS

Ø 13 mm-22 w

### 1 DESCRIPTION

- Magnetic circuit encapsulated with thermoplastic resins.
- Standard colour black.
- Metallic parts protected against oxidation.

### 2 ORDERING CODE

(1)	(2)	(3)
C36	-	-

C36-\*\*\*\* : DIN 43650/A  
 C36/C-\*\*\*\* : flying leads  
 C36/K-\*\*\*\* : kostal M27x1  
 C36/A-\*\*\*\* : AMP Junior

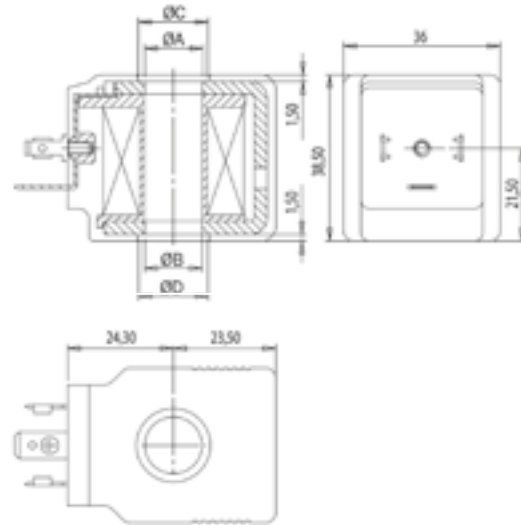

### 3 TECHNICAL DATA

Typical nominal voltages	- 12-24VDC - 24-110-220RAC
Class H coil as from the IEC	85 standard
Class H wire	200°C
Duty cycle	ED 100% code, voltages, currents and power consumption.
see table for coils:	012C, 024C, 048C for VDC 024R, 110R, 220R for RAC (rectified alternate current)

Coil with ISO/DIN connector	voltage DC	nominal current (A)	resistance cold (Ω)	nominal power (W)	insulation class
C36-012C	V 12 DC	1,9	6,3	22,8	H
C36-024C	V 24 DC	0,95	25,6	22,5	
C36-024R	V 24 RAC	1,05	20,2	23	
C36-048C	V 48 DC	0,47	102	22,6	
C36-110R	V 110-115 RAC	0,23	420	22,9	
C36-220R	V 220-230 RAC	0,11	1720	22,3	

C36L-\*\*\*  
DIN 4365/A-ISO 4400

C36L/D-\*\*\*  
DEUTSCH

C36L/C-\*\*\*  
FLYING LEADS

C36L/A-\*\*\*  
AMP JUNIOR

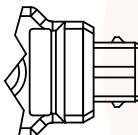
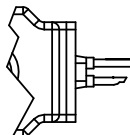
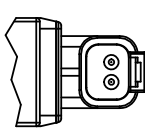
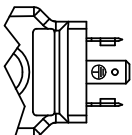
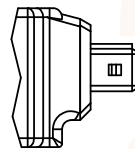
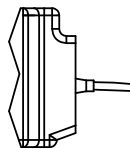
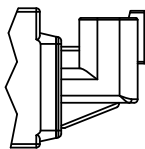
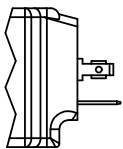



## SCREW IN POPPET CHECK VALVE CAVITY 3/4" 16 UNF

### VUC-34\*

40 l/min 35 MPa (350 bar)

#### 1 DESCRIPTION

VUC is a poppet check valve in standard cavity 3/4" 16UNF.  
The external surface is zinc coated.  
The tightness is guarantee by high precision machining parts and by the poppet design.  
Different cracking pressure available on demand.



#### 2 ORDERING CODE

(1)	(2)	(3)
VUC	- 34	-

- (1) VUC: check valve
- (2) 34: cavity 3/4" 16 UNF (ø 12,7 mm)
- (3) Cracking pressure
  - no designation: 3 bar (standard execution)
  - 1: 8 bar

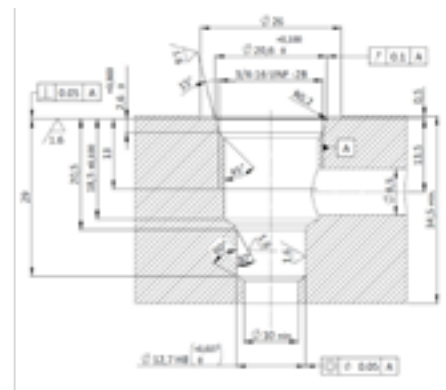

#### 3 TECHNICAL DATA

Maximum flow	40 l/min
Maximum pressure	350 bar (35 MPa)
Installation torque	40-45 Nm
Weight	0,06 Kg

#### 4 TYPICAL DIAGRAMS

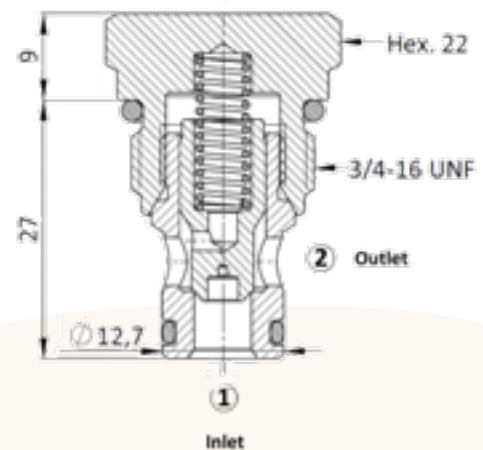
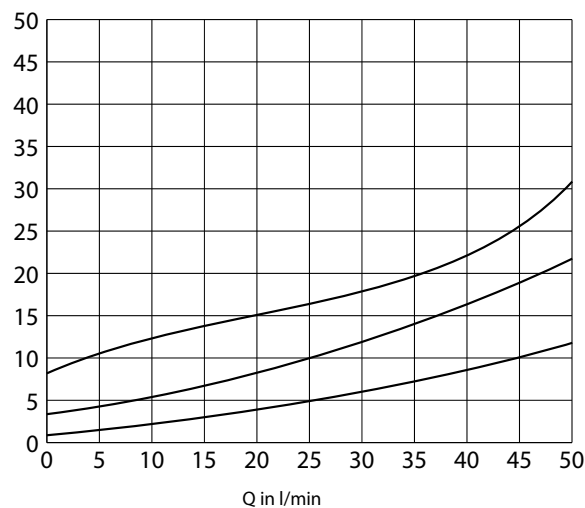

Valve is designed as simple lock or load-holding device. Flow is free from 1 to 2 and valve opens against the force of the spring. In the direction 2 -1 the flow is blocked and not permitted. Tightness is assured by high quality poppet made in hardened steel.



## HYDRAULIC SCREW-IN VALVES PRESSURE RELIEF-DIRECT ACTING MO-010

16 l/min 25 MPa (250 bar)

### 1 DESCRIPTION

MO-010 is a direct operated pressure relief valve in standard cavity 3/4" 16UNF.

The external surface is zinc coated. With a single pressure setting it is possible to cover a wide range of regulations. The simple design is perfect for application with low flow rates such as mini power units.



### 2 ORDERING CODE

(1)	(2)	(3)
MO	- 010	/ 25

(1) MO: Direct acting relief valve

(2) 010: Nominal size (3/4" 16 UNF)

(3) 25: Spring type (setting range 25 to 250 bar)

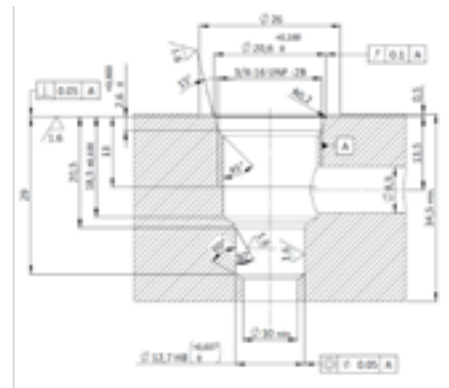

### 3 TECHNICAL DATA

Maximum flow	16 l/min
Maximum pressure	25 MPa (250 bar)
Mass	0,14 Kg

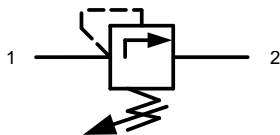
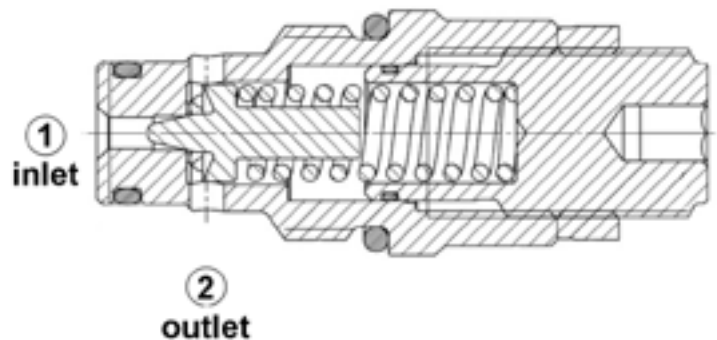





## HYDRAULIC SCREW-IN VALVES PRESSURE RELIEF-DIRECT ACTING MO-020

25 l/min 35 MPa (350 bar)

### 1 DESCRIPTION

MO-020 is a direct operated pressure relief valve in standard cavity 3/4" 16UNF.  
The external surface is zinc coated.  
There are three different pressure settings for a more accurate regulation.



### 2 ORDERING CODE

(1)	(2)	(3)
MO	- 020	/

(1) MO: Direct acting relief valve

(2) 020: Nominal size

(3) Spring type:

- 10: setting 32-125bar, increase 15 bar/turn,
- 20: setting 63-200bar, increase 30 bar/turn,
- 32: setting 125-350bar, increase 40 bar/turn,

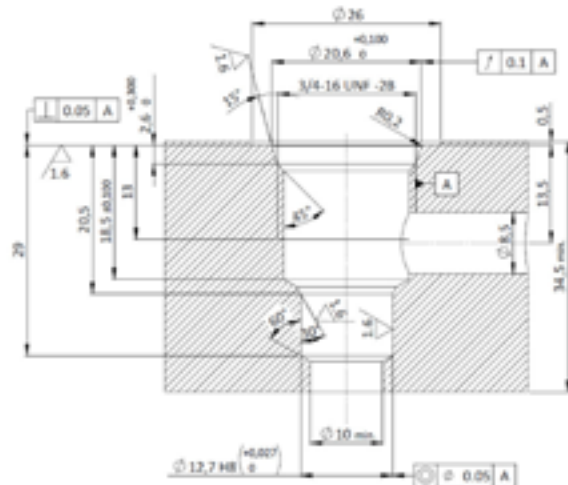

### 3 TECHNICAL DATA

Maximum flow	25 l/min
Maximum pressure	25 MPa (250 bar)
Mass	0,13 Kg

### 4 TYPICAL DIAGRAMS

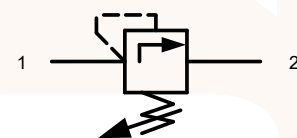
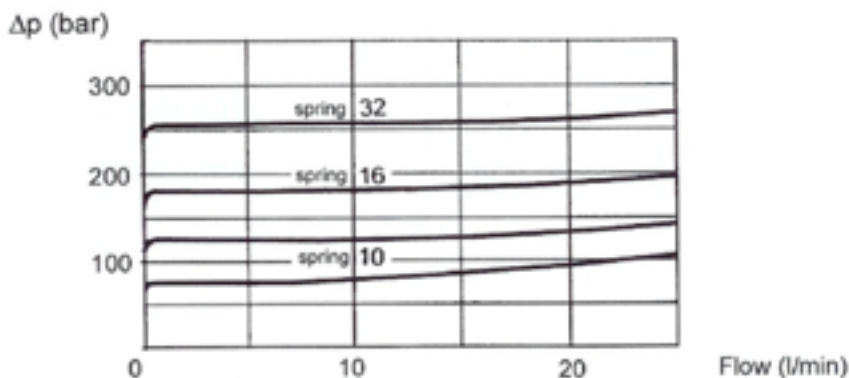
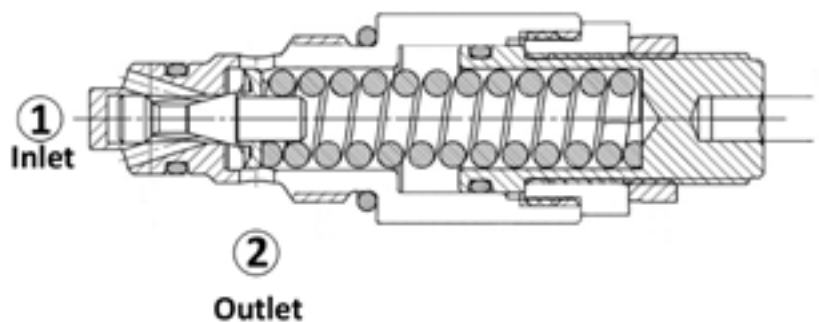

## 5 INSTALLATION DIMENSIONS

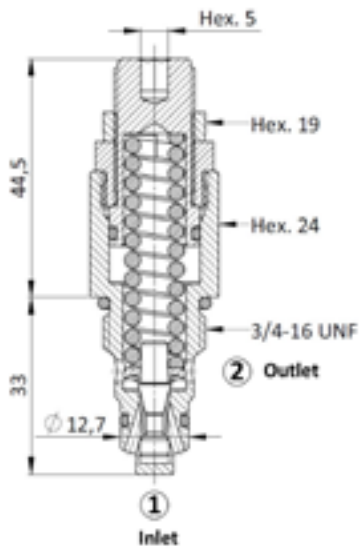

### SPARE PARTS

Position	Code	Description
1	ZOR084	O-Ring $\varnothing$ 16,36 x 2,20 70 Sh
2	0F.A2.001	Teflon Ring $\varnothing$ 9,7 x 12,7 x 1,4
3	ZOR027	O-Ring $\varnothing$ 9,25 x 1,78 70 Sh
Inner	ZORO28	O-Ring $\varnothing$ 14 x 1,78 70 Sh

## 6 LINE ASSEMBLY BODY

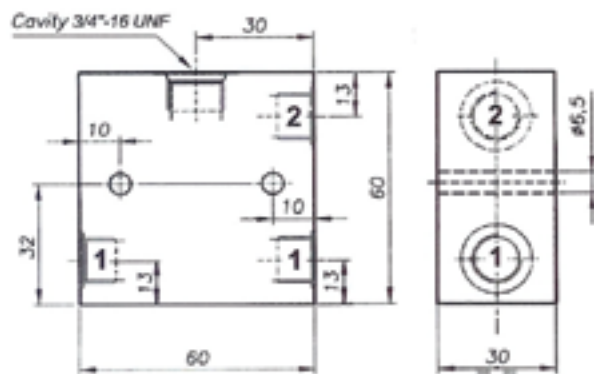

code	ports
LAB-34-2/14	1/4" BSP
LAB-34-2/38	3/8" BSP
Mass 0,25	

Suitable for standard 2-way screw-in valves, cavity 3/4" 16 UNF. Designed for in-line assembly, either parallel or in series one, LAB aluminium bodies are supplied with one service port (1) plugged.



## HYDRAULIC SCREW-IN VALVES FLOW CONTROL-ADJUSTABLE FT266/VCF

20 l/min 35 MPa (350 bar)

### 1 DESCRIPTION

It is possible to choose different type of flow regulators in standard cavity 3/4" 16UNF.

FT266/5 has a fine control in one direction. FT266/2 controls both flow directions. In these two models the regulation is made by a precision hand-grip with locking screw.

The model VCF-34 is always a bi-directional flow control valve but suitable for lower flow rates and without hand knob.



### 2 ORDERING CODE

(1)	(2)	(3)	(4)	or			
FT	-	/	- 34		VCF	-	34

(1) FT: Direct acting relief valve

(2) Nominal size  
266: 20 l/min- Mass 0,13

(3) Spring type  
2: 20 l/min- Mass 0,13  
5: 20 l/min- Mass 0,15

(4) 34: design number (progressive) of the valve

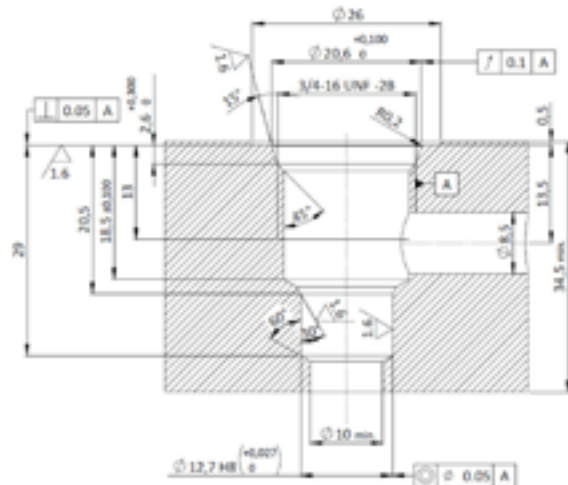

### 3 TECHNICAL DATA

Maximum flow	20 l/min- 16 l/min (VCF-34)
Maximum pressure	35 MPa (350 bar)
Mass	0,15 Kg- 0,13 Kg - 0,12 Kg

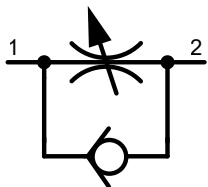

FT266/5



FT266/2  
or  
VCF-34



## 4 TYPICAL DIAGRAMS

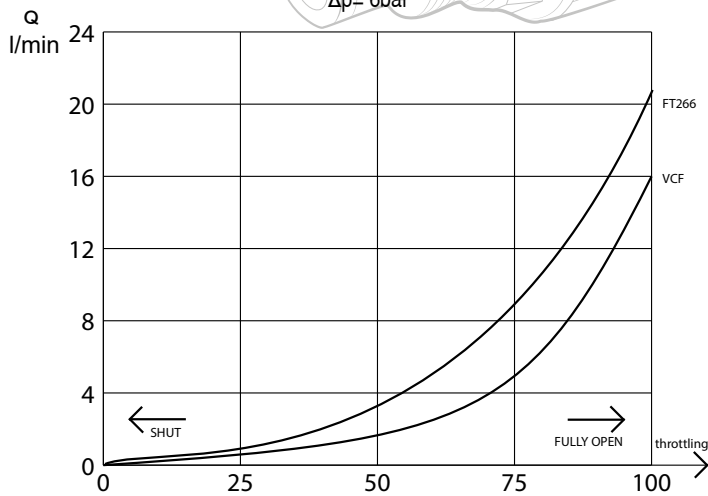

Typical Q curves a different throttling sections and fixed  $\Delta p = 6 \text{ bar}$  for valves FT266/VCF. Standard configuration with mineral oil at 42cSt and 50° C.

## 5 INSTALLATION DIMENSIONS

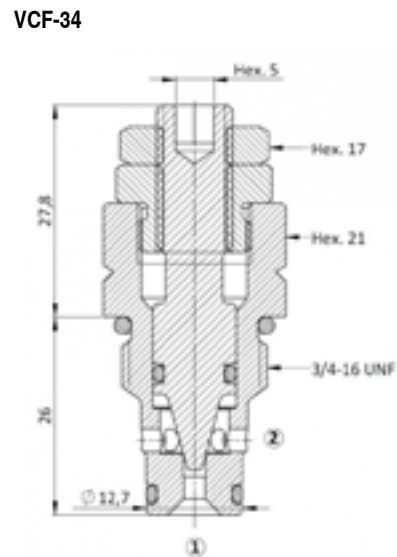
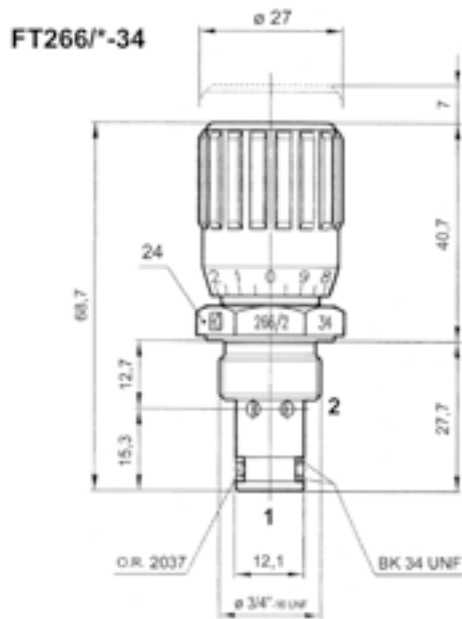

## 6 LINE ASSEMBLY BODY

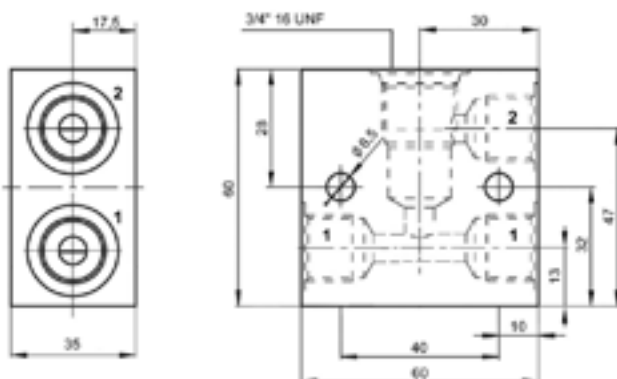

Code	Ports
LAB-34-2/14	1/4" BSP
LAB-34-2/38	3/8" BSP
MASS: 0,25 kg	

Suitable for standard 2-way screw-in valves, cavity 3/4" 16 UNF. Designed for in-line assembly, either parallel or in series one, LAB aluminium bodies are supplied with one service port (1) plugged.



## HYDRAULIC SCREW-IN FLOW CONTROL VALVES- PRESSURE COMPENSATED VQF

12 l/min 25 MPa (250 bar)

### 1 DESCRIPTION

2-way pressure compensated flow control valve Suitable for standard cavity 3/4" 16 UNF Not adjustable type: available in different fixed delivery rates (from 1 to 12 l/min – accuracy: ±10% at 100 bar) Maximum operating pressure: 250 bar Reverse flow through the same regulating orifice, without pressure compensation. Steel body. Poppet in hardened and grinded steel.

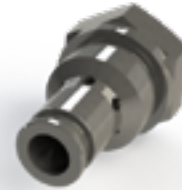

### 2 ORDERING CODE

(1)	(2)	(3)
VQF	- 34	/

(1) VQF: Pressure compensated flow control valve

(2) 34: Nominal size

(3) Flow rate:

- 1-1 l/min
- 2-2 l/min
- 3-3 l/min
- 4-4 l/min
- 5-5 l/min
- 6-6 l/min
- 09-9 l/min
- 12-12 l/min

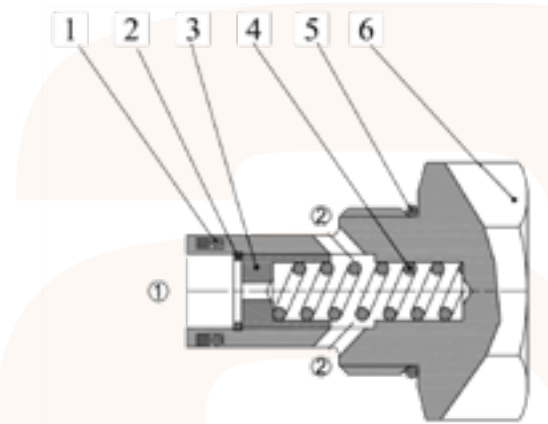
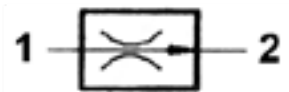
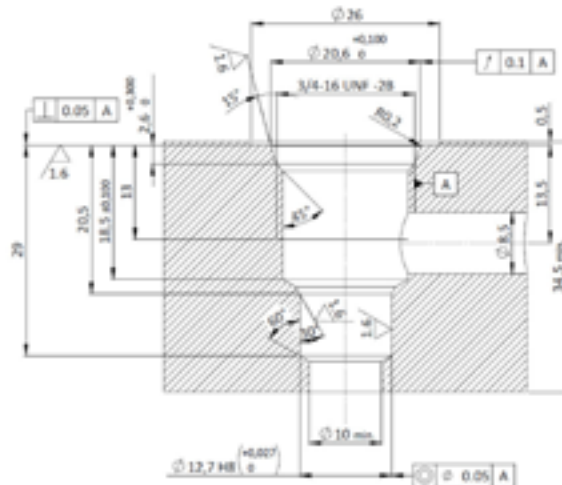

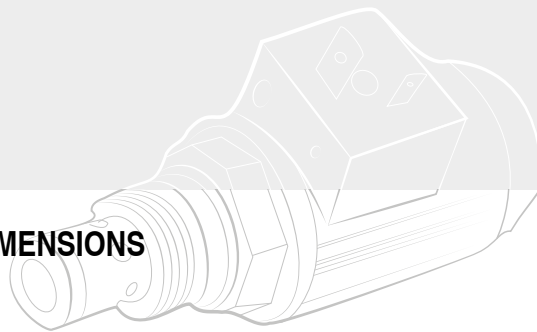

### 3 INSTALLATION DIMENSIONS

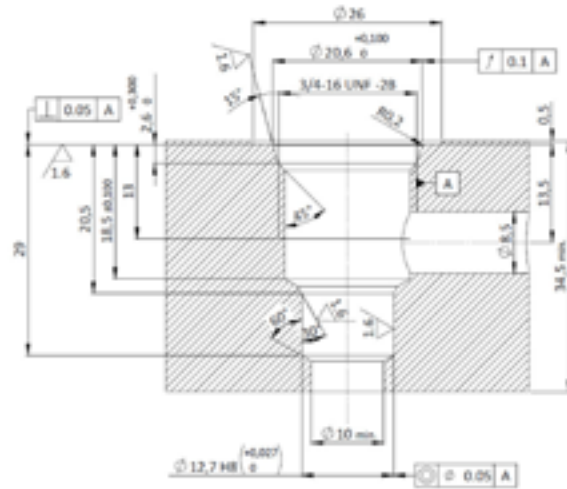
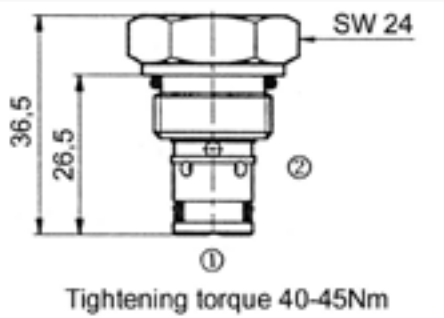

### 4 LINE ASSEMBLY BODY

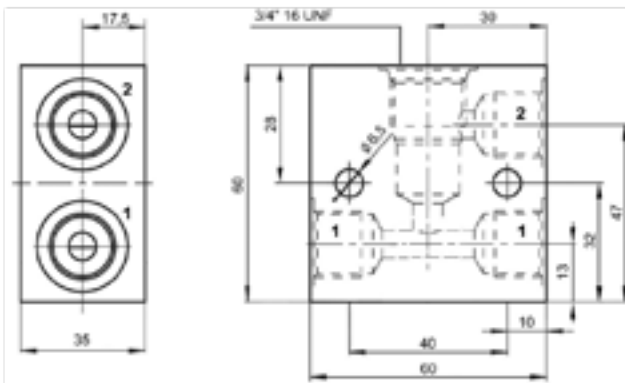

Code	Ports
LAB-34-2/14	1/4" BSP
LAB-34-2/38	3/8" BSP
MASS: 0,25 kg	

Suitable for standard 2-way screw-in valves, cavity 3/4" 16 UNF. Designed for in-line assembly, either parallel or in series one, LAB aluminium bodies are supplied with one service port (1) plugged.



### LINE ASSEMBLY BODIES FOR 2-WAY SCREW-IN VALVES

## LAB

35 MPa (350 bar)

### 1 DESCRIPTION

Suitable for standard 2-way screw-in valves  
 In-line parallel assembly: all ports connected  
 In-line series assembly: one port n 1 plugged  
 Standard execution with plug on port n 1  
 Material: aluminium  
 Maximum operating pressure: 350 bar  
 Cavity according to UNF standards, BSP ports



### 2 ORDERING CODE

(1)	(2)	(3)	(4)
LAB	-	2	/

(1) LAB: Line assembly body

(2) Nominal size  
 34: Cavity 3/4" - 16 UNF  
 78: Cavity 7/8" - 14 UNF

(3) 2: 2-way valves

(4) Port configuration  
 14: ports 1/4" BSP (LAB-34 only)  
 38: ports 3/8" BSP  
 12: ports 1/2" BSP (LAB-78 only)

### 3 LAB-34-2/\*\* Mass: 0,25 kg

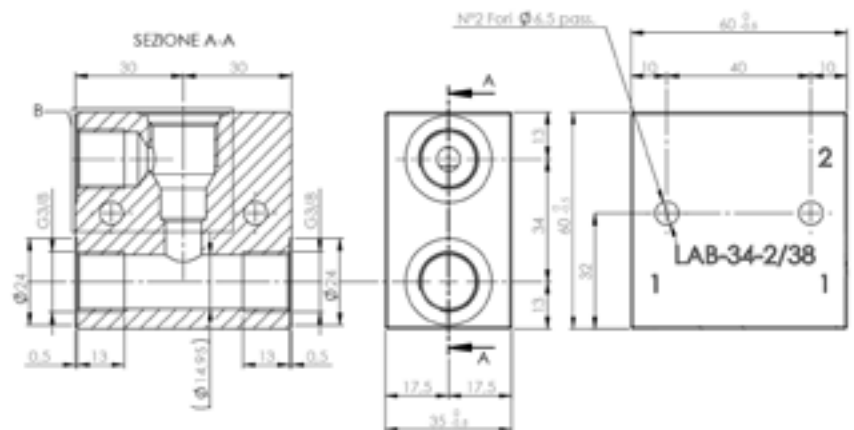

### 4 LAB-78-2/\*\* Mass: 0,37 kg

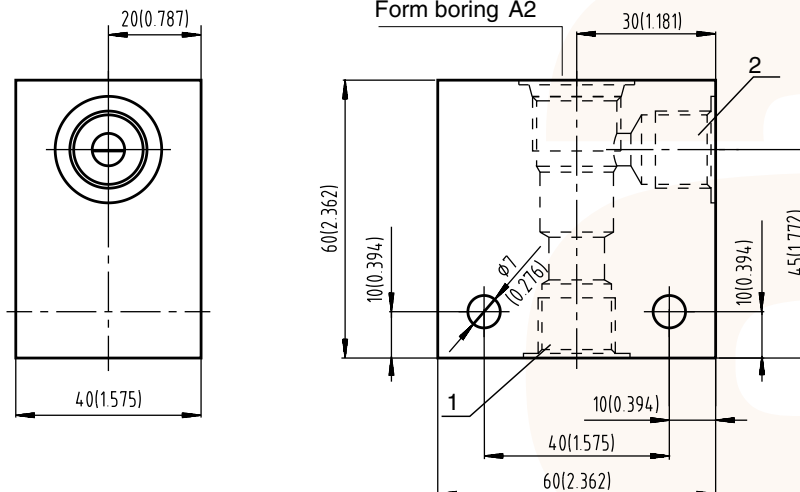



## HYDRAULIC SCREW-IN VALVES PRESSURE RELIEF-DIRECT ACTING MO-4

50 l/min 35 MPa (350 bar)

### 1 DESCRIPTION

Suitable for standard cavity 7/8" 14 UNF 2-way direct acting relief valves Differential area poppet type Fast response and low hysteresis in shutting Maximum operating pressure: 350 bar Maximum flow rate: 50 l/min External parts zinc plated Steel body Poppet in tempered and grinded steel Mass 0,13 kg



### 2 ORDERING CODE

(1)	(2)	(3)
MO	- 4	/

(1) MO: Direct acting relief valve

(2) 4: Nominal size

(3) Spring type:

10: setting 20-130 bar, Increase 16,5 bar/turn

16: setting 40-180 bar, Increase 16,5 bar/turn

32: setting 60-350 bar, Increase 51 bar/turn

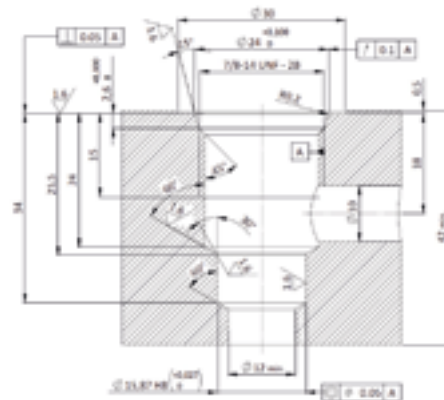

### 3 TYPICAL DIAGRAMS

$\Delta p$  (bar)

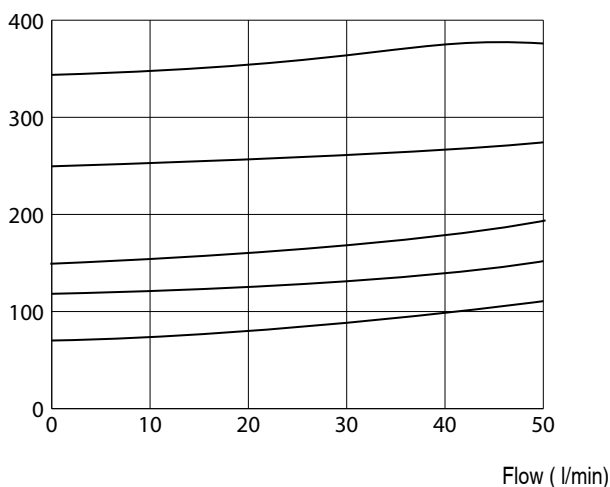

After final test the valve are respectively set to 100, 180 and 350 bar ( $\pm 10\%$ ) with 5 l/min flow rate

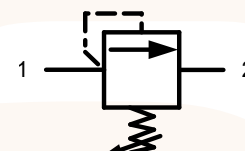

**4 INSTALLATION DIMENSIONS**

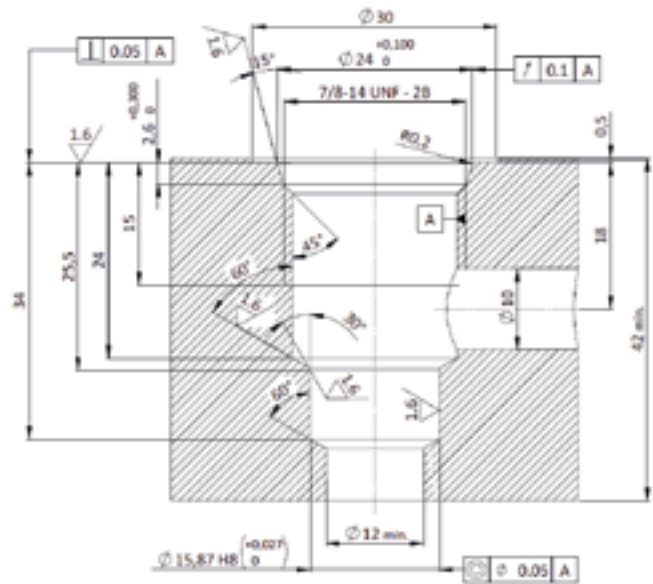
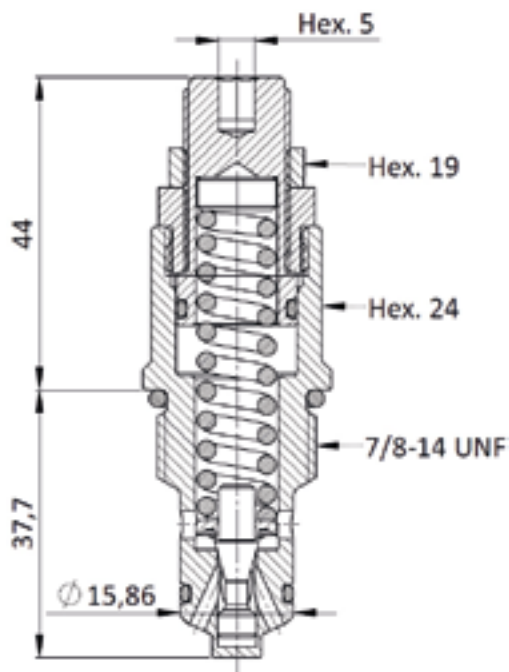

**SPARE PARTS**

Position	Code	Description
1	Z0R084	O-Ring $\varnothing$ 19,18 x 2,46 70Sh
2	0F.A2.001	Teflon Ring $\varnothing$ 12,8 x 15,86 x 1,4
3	Z0R027	O-Ring $\varnothing$ 12,42 x 1,78 70 Sh
Inner	Z0R028	O-Ring $\varnothing$ 19,18 x 2,46 70 Sh

**5 LINE ASSEMBLY BODY**

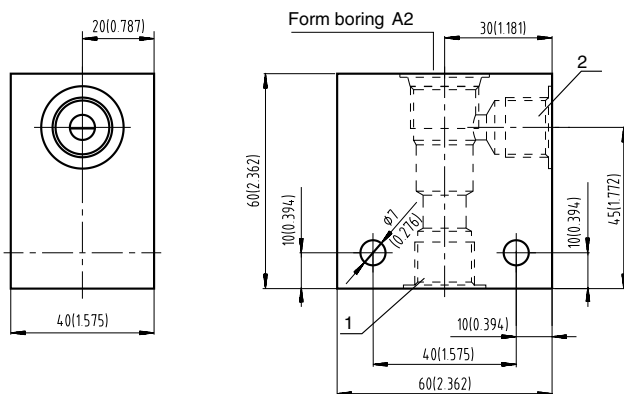

Code	Ports
LAB-78-2/38	3/8" BSP
LAB-78-2/12	1/2" BSP
MASS: 0,37 kg	

Suitable for standard 2-way screw-in valves, cavity 7/8" 14 UNF.



## HYDRAULIC SCREW-IN VALVES PRESSURE RELIEF-DIRECT ACTING MO-4L

70 l/min 25 MPa (250 bar)

### 1 DESCRIPTION

Suitable for standard cavity 7/8" 14 UNF 2-way direct acting relief valves  
Differential area poppet type Fast response and low hysteresis in shutting  
Maximum operating pressure: 250 bar Maximum flow rate: 70 l/min Ex-  
ternal parts zinc plated Steel body Poppet in tempered and grinded steel  
Anti vibration system Mass 0,13 kg



### 2 ORDERING CODE

(1)	(2)	(3)
MO	- 4L	/ 20

(1) MO: Direct acting relief valve

(2) 4: Nominal size (7/8" 14 UNF)

(3) 20: Spring type, setting 110 to 220 bar increase (bar/turn) 31.5

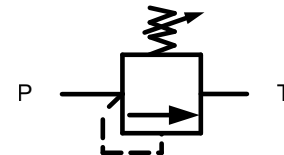

### 3 TECHNICAL DATA

Max working pressure	250 bar
Max flow	70 l/min
External parts zinc plated	

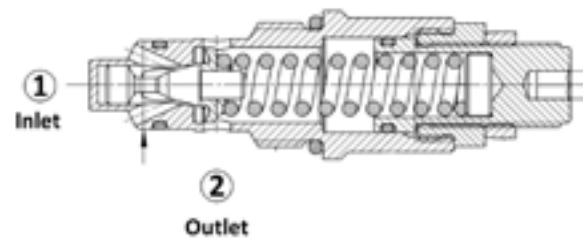

Normally the poppet (with damping spool) is kept closed by compression spring. When, on P port, pressure exceeds the settled value, poppet is pushed by axial hydraulic forces, overcomes the force of spring, shifts in its cylindrical seat and opens to the pressurized fluid annular passage to T, thus keeping the pressure level at the requested value.

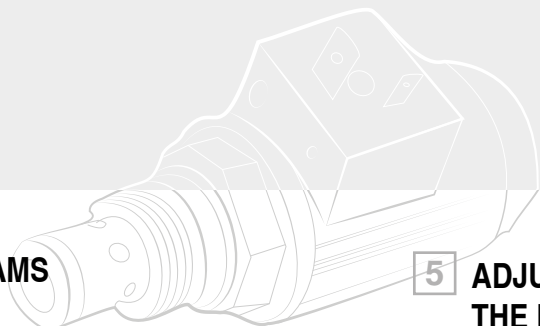

## 4 TYPICAL DIAGRAMS

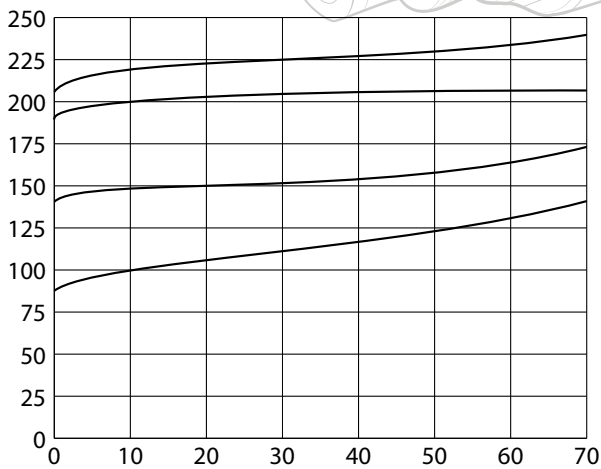

## 5 ADJUSTMENT OF THE RELIEF PRESSURE

Relief pressure is reached when the axial hydraulic forces on poppet equal the force on spring; The value of the relief pressure can be therefore changed by changing the compression of the spring. To increase the relief pressure, turn clockwise the adjustment nut , after having unlocked the retaining nut.

## 6 INSTALLATION DIMENSIONS (mm)

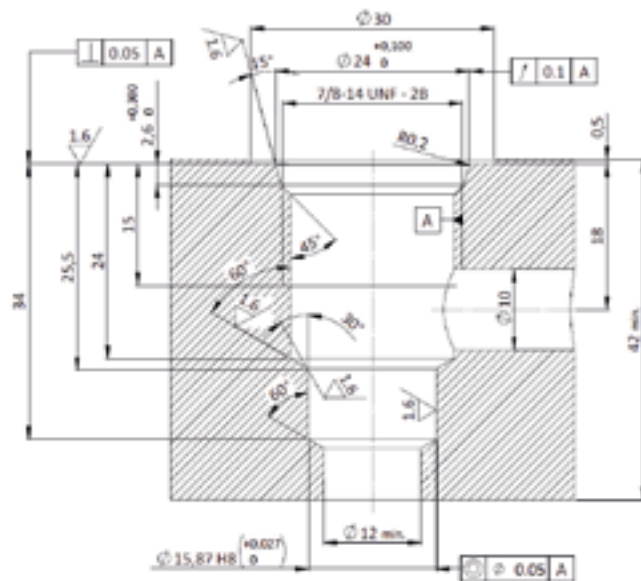
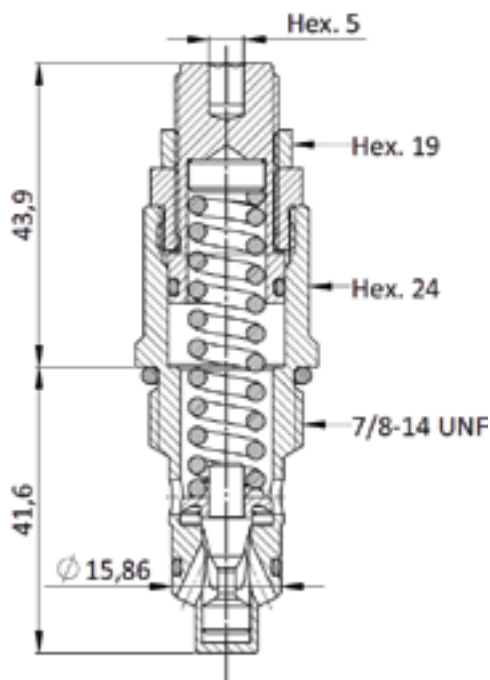

### SPARE PARTS

Position	Description
1	O-Ring $\varnothing 19,18 \times 2,46$ 70Sh
2	O-Ring $\varnothing 12,42 \times 1,78$ 70Sh
3	Backup Ring $\varnothing 13 \times 15,8 \times 0,7$





### 3 TECHNICAL DATA

Nominal flow rate	32 l/min	Electric characteristics: Those solenoid operated valves are normally equipped by coils type B02, which are energized: directly from a D.C. voltage supply V 12 DC = 012C V 24 DC = 024C by the use of coils that incorporate a full wave bridge rectifier, from A.C. voltage supply : V 110/50 - V 115/60 = 115A V 220/50 - V 230/60 = 230A
Maximum rec. flow rate	40 l/min	
Maximum pressure	25 MPa (250 bar)	
Installation and dimensions	see 7	
Duty cycle	ED 100%	
Mass (without coil)	0,22 kg	

### 4 TYPICAL DIAGRAMS

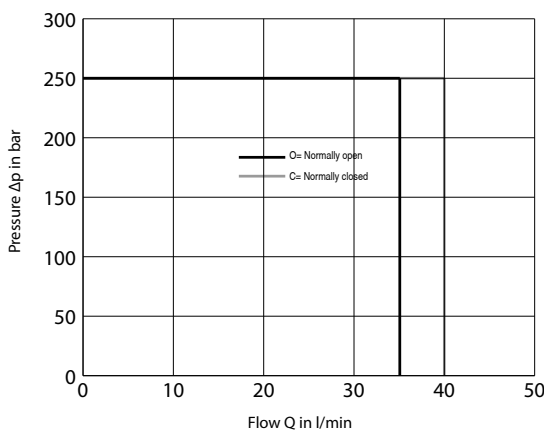

### 5 HYDRAULIC LIMIT OF USE

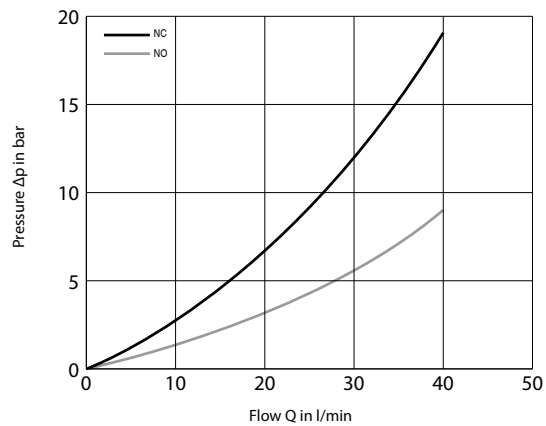

### 6 CONNECTORS

All connectors must conform to ISO 4400 (DIN 43650) and electric circuitry must be able to carry the following rated current values :

V 12 DC = 2,4 A V 115/50 = 0,26 A

V 24 DC = 1,2 A V 230/50 = 0,14 A

Coils with 2 electric pins, conforming with AMP connectors, are only available for DC supply (example of code : B02-012C AMP).

### 8 VARIANTS OF MANUAL OVERRIDE

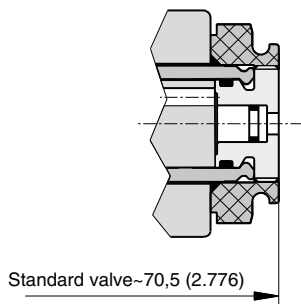

### 7 INSTALLATION DIMENSIONS

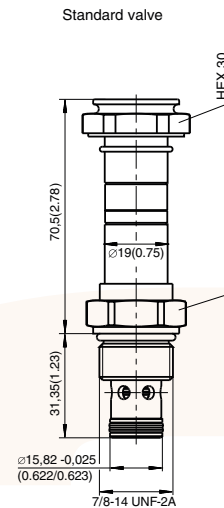

EV2\*.78 valves are to be installed in cavity 7/8" 14 UNF . Check the appropriate state and position of the seals, screw the valve in the cavity and lock it with a torque of about 40 Nm applied on the 27 mm hexagon.

**9 COILS TYPE B02 (Ø 19mm)**

**DIN 4365/A-ISO 4400**

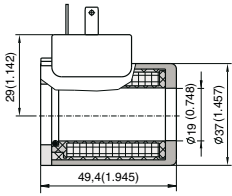

**AMP (Amp Junior Timer)**

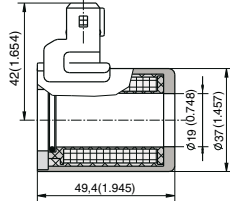

**AMPX (Amp Junior Axial)**

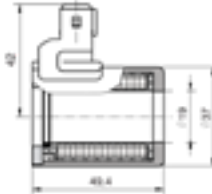

**Deutsch**

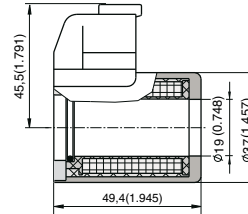

**DIN 4365/A-ISO 4400  
With Built-in rectifier**

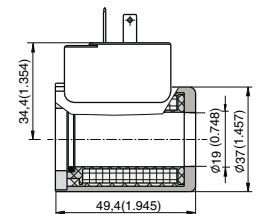

**10 LINE ASSEMBLY BODY**

LAB-78-2/38, 3/8" BSP, Alluminium Alloy, Mass 0,54 Kg

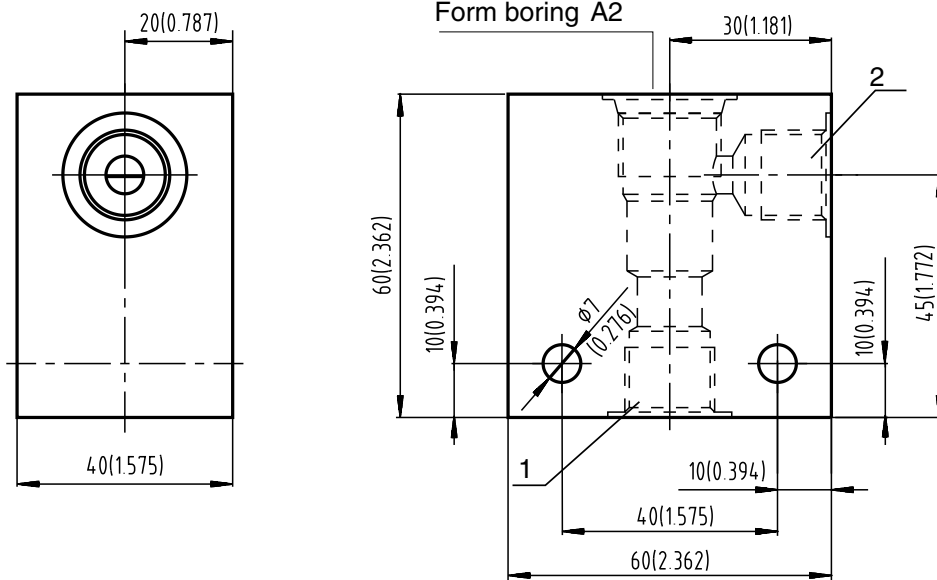



### SCREW-IN, 3-WAY SOLENOID OPERATED DIRECTIONAL VALVE CAVITY 7/8" 14 UNF-SAE 10/3 spool type EV3\*.78.\*

40 l/min 25 MPa (250 bar)

#### 1 DESCRIPTION

Directional control valve 3 way 2 position spool type. Is possible to have this valve in different spool configurations. On demand a high performance version is available in case of higher flow rates or pressure. The dual seals rings assure an efficient and reliable tightness of the valve.



#### 2 ORDERING CODE

(1)	(2)	(3)	(4)	(5)	(6)	(7)
EV3	-	78	-	-	-	/

(1) EV3 : 3-way solenoid operated spool type

(2) Spool type

- C: normally closed
- O: normally open

(3) 78 : cavity 7/8" 14 UNF

(4) Valves variants (see 7)

- 03: without manual override
- 04: manual override push type (standard)
- 05: manual override screw type

(5) Electric voltage and solenoid coils (see 9)

- 0000 : no coils
- 012C : coils for V12DC
- 024C : coils for V24DC
- 115A : coils for V110/50 – V 115/60 AC
- 230A : coils for V220/50 – V 230/60 AC

(6) Options for coil connection

- no designation : standard connection ISO4400/DIN43650/A
- D: Deutsch;
- A: AMP Junior Timer;
- AMPX

(7) Design number (progressive) of the valves

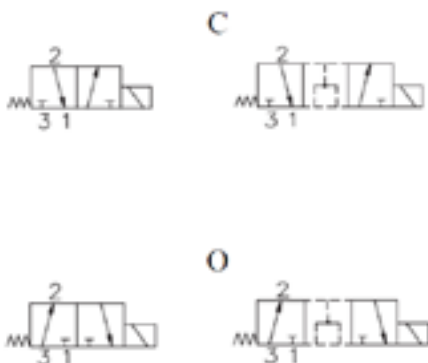

Recommended use of ports: 3=P; 1=T

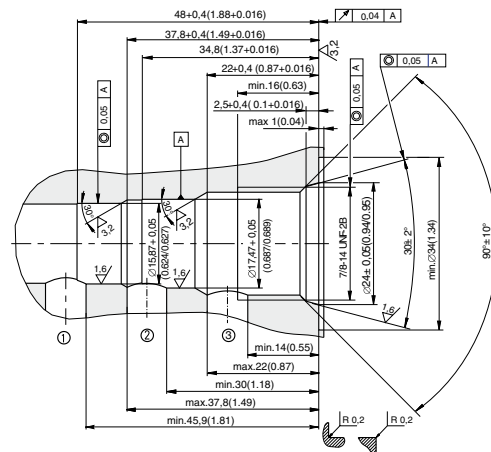

Standard performance

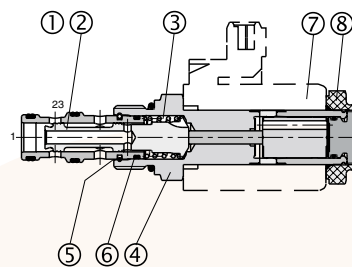

Screw-in 3/2 solenoid valves type EV3\*.78 are composed by a valve sleeve 1, a control spool 2, a return spring 3, and an actuating assembly 4 that comprises the magnetic parts and the screwing section. An energizing electric solenoid coil 5 is fastened to the assembly by means of a retaining nut 6. When solenoid coils is energized, a magnetic mobile armature shifts and by means of a rod installed inside assembly, moves the control spool which makes hydraulic connections between 1,2,3 ports.

### 3 TECHNICAL DATA

Nominal flow rate	32 l/min	Electric characteristics:
Maximum rec. flow rate	40 l/min	Those solenoid operated valves are normally equipped by coils type B02, which are energized:
Maximum pressure	25 MPa (250 bar)	directly from a D.C. voltage supply
Installation and dimensions	see 8	V 12 DC = 012C
Duty cycle	ED 100%	V 24 DC = 024C
Mass (without coil)	0,24 kg	by the use of coils that incorporate a full wave bridge rectifier, from A.C. voltage supply :
		V 110/50 - V 115/60 = 115A
		V 220/50 - V 230/60 = 230A

### 4 TYPICAL DIAGRAMS

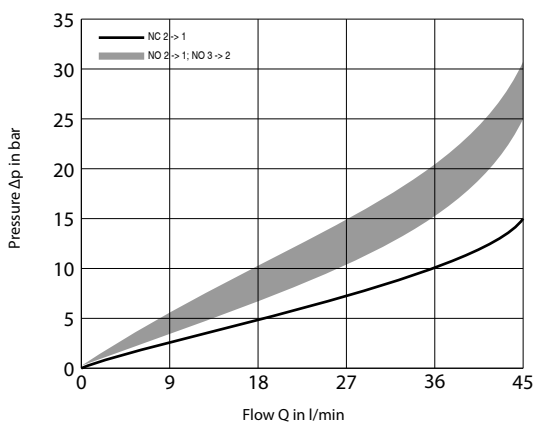

### 5 HYDRAULIC LIMIT OF USE

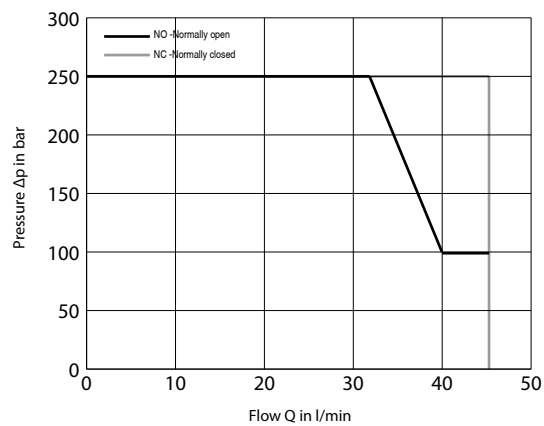

### 6 CONNECTORS

All connectors must conform to ISO 4400 (DIN 43650) and electric circuitry must be able to carry the following rated current values :

V 12 DC = 2,4 A V 115/50 = 0,26 A

V 24 DC = 1,2 A V 230/50 = 0,14 A

Coils with 2 electric pins, conforming with AMP connectors, are only available for DC supply (example of code : B02-012C AMP).

### 7 VARIANTS OF MANUAL OVERRIDE

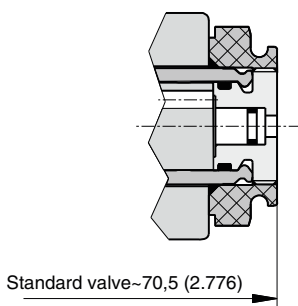

### 8 INSTALLATION DIMENSIONS

Standard valve

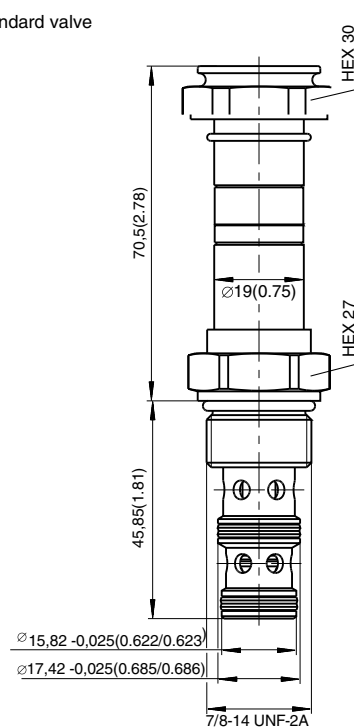

EV3\*.78 valves are to be installed in cavity 7/8" 14 UNF . Check the appropriate state and position of the seals, screw the valve in the cavity and lock it with a torque of about 40 Nm applied on the 27 mm hexagon.

## 9 COILS TYPE B02 (Ø 19mm)

DIN 4365/A-ISO 4400

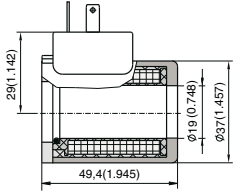

AMP (Amp Junior Timer)

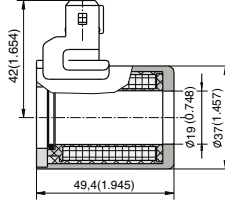

AMPX (Amp Junior Axial)

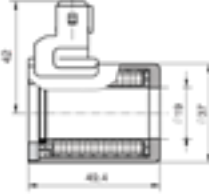

Deutsch

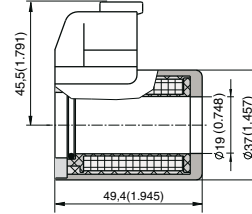

DIN 4365/A-ISO 4400  
With Built-in rectifier

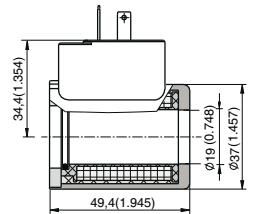

## 10 LINE ASSEMBLY BODY

LAB-78-3/38, 3/8" BSP, Alluminium Alloy, Mass 0,60 Kg

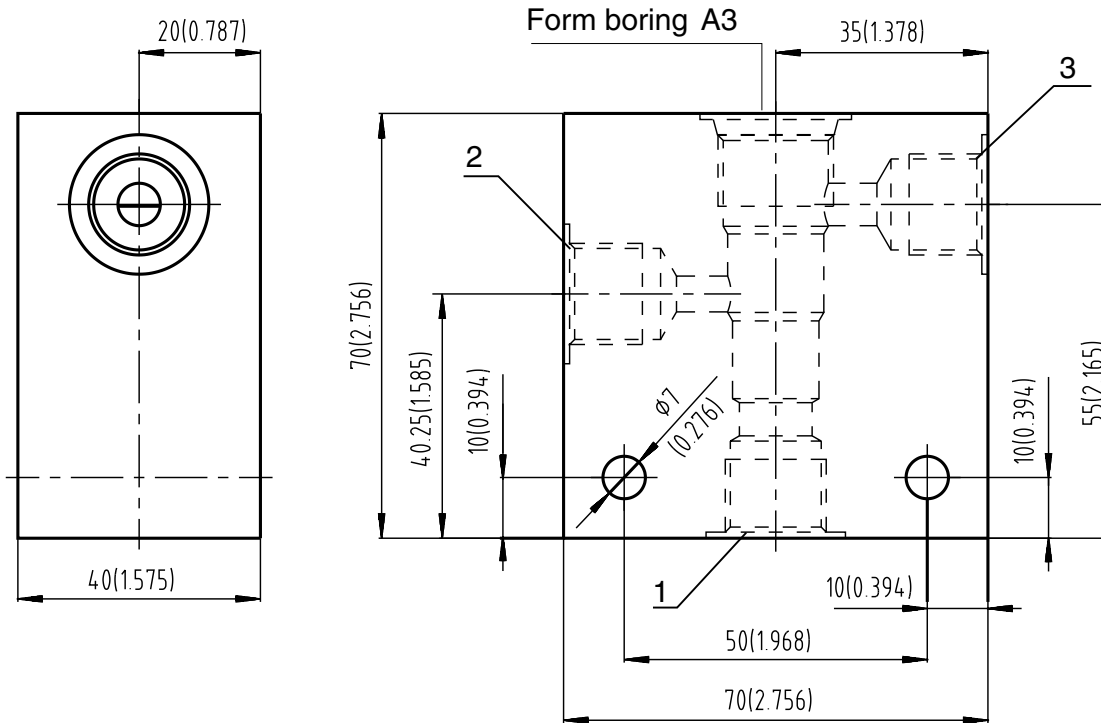



## SCREW-IN, 4-WAY SOLENOID OPERATED DIRECTIONAL VALVE CAVITY 7/8" 14 UNF-SAE 10/4 spool type EV4\*\*.78.\*

40 l/min 25 MPa (250 bar)

### 1 DESCRIPTION

Directional control valve 4 way 2 position spool type.  
Is possible to have this valve in different spool configurations. On demand a high performance version is available in case of higher flow rates or pressure.  
The dual seals rings assure an efficient and reliable tightness of the valve.



### 2 ORDERING CODE

(1)	(2)	(3)	(4)	(5)	(6)	(7)
EV4	-	-	78	-	-	/

(1) EV4 : 4-way solenoid operated spool type

(2) Spool type:

- XP
- CX
- CP

(3) 78 : cavity 7/8" 14 UNF

(4) Valves variants (see 8)

- 03: without manual override
- 04: manual override push type (standard)
- 05: manual override screw type

(5) Electric voltage and solenoid coils (see 9)

- 0000 : no coils
- 012C : coils for V12DC
- 024C : coils for V24DC
- 115A : coils for V110/50 – V 115/60 AC
- 230A : coils for V220/50 – V 230/60 AC

(6) Options for coil connection

- no designation : standard connection ISO4400/DIN43650/A
- D: Deutsch;
- A: AMP Junior Timer;
- AMPX

(7) Design number (progressive) of the valves.

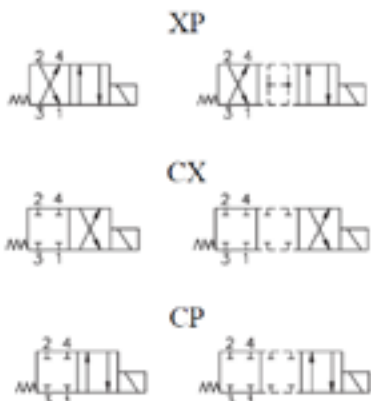

Recommended use of ports  
3=P; 1=T 2=A; 4=B

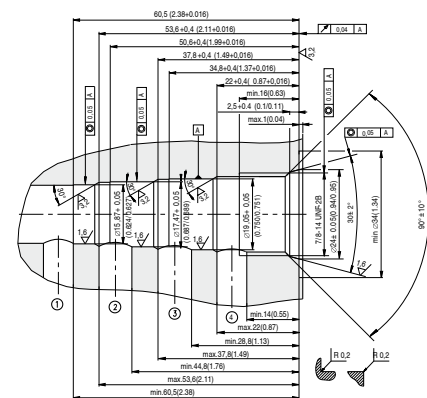

Standard performance

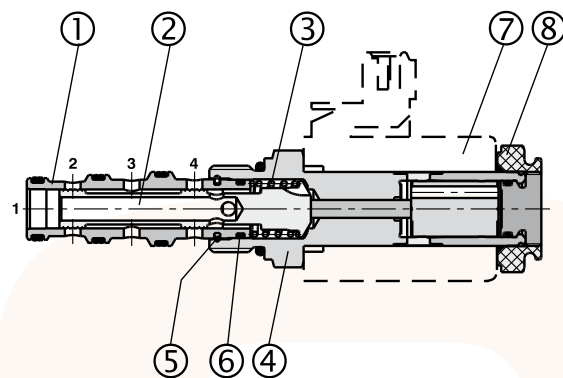

Screw-in 4/2 solenoid valves type EV4\*\*.78 are composed by a valve sleeve 1, a control spool 2, a return spring 3, and an actuating assembly 4 that comprises the magnetic parts and the screwing section. An energizing electric solenoid coil 5 is fastened to the assembly by means of a retaining nut 6. When solenoid coils is energized, a magnetic mobile armature shifts and by means of a rod installed inside assembly, moves the control spool which makes hydraulic connections between 1,2,3,4 ports.

### 3 TECHNICAL DATA

Nominal flow rate	32 l/min	Electric characteristics:
Maximum rec. flow rate	40 l/min	Those solenoid operated valves are normally equipped by coils type B02, which are energized:
Maximum pressure	25 MPa (250 bar)	directly from a D.C. voltage supply
Installation and dimensions	see 7	V 12 DC = 012C
Duty cycle	ED 100%	V 24 DC = 024C
Mass (without coil)	0,25 kg	by the use of coils that incorporate a full wave bridge rectifier, from A.C. voltage supply :
		V 110/50 - V 115/60 = 115A
		V 220/50 - V 230/60 = 230A

### 4 TYPICAL DIAGRAMS

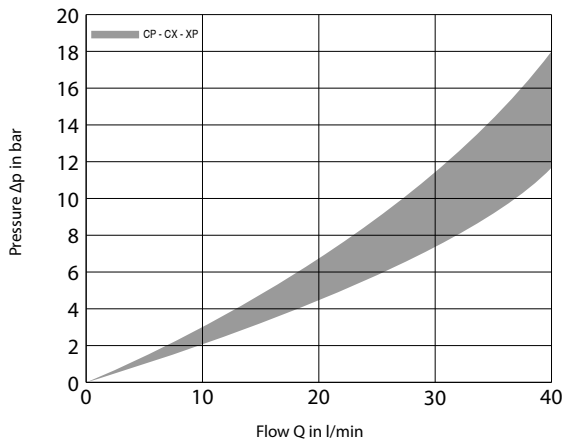

### 5 HYDRAULIC LIMIT OF USE

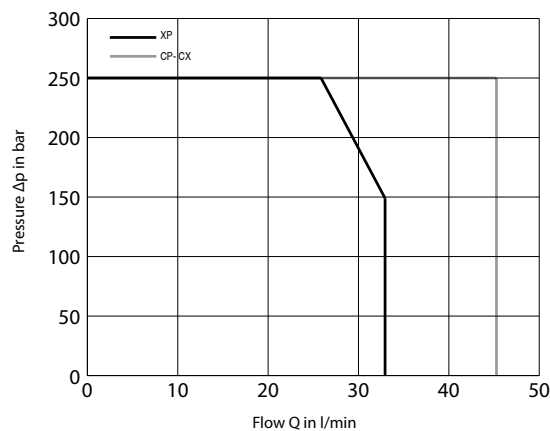

### 6 CONNECTORS

All connectors must conform to ISO 4400 (DIN 43650) and electric circuitry must be able to carry the following rated current values :

V 12 DC = 2,4 A V 115/50 = 0,26 A

V 24 DC = 1,2 A V 230/50 = 0,14 A

Coils with 2 electric pins, conforming with AMP connectors, are only available for DC supply (example of code : B02-012C AMP).

### 7 INSTALLATION DIMENSIONS

Standard valve

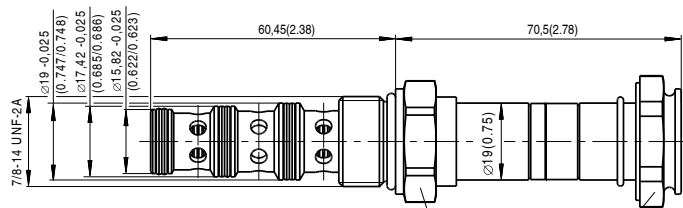

### 8 VARIANTS OF MANUAL OVERRIDE

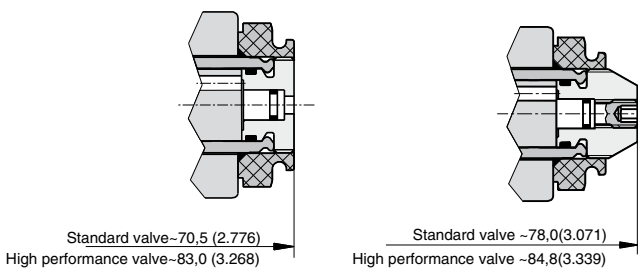

EV4\*\* .78 valves are to be installed in cavity 7/8" 14 UNF. Check the appropriate state and position of the seals, screw the valve in the cavity and lock it with a torque of about 40 Nm applied on the 27 mm hexagon.



**9 COILS TYPE B02 (Ø 19 mm)**

DIN 4365/A-ISO 4400

AMP (Amp Junior Timer)

AMPX (Amp Junior Axial)

Deutsch

DIN 4365/A-ISO 4400  
With Built-in rectifier

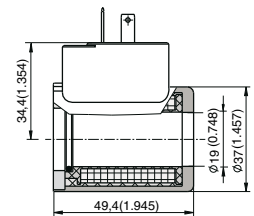
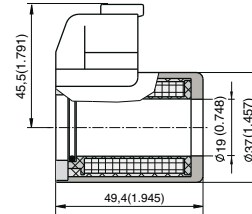
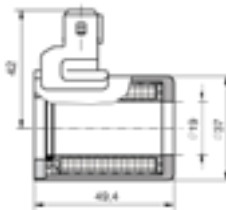
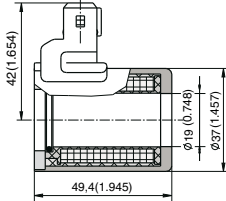
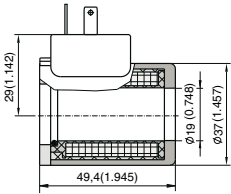

**10 LINE ASSEMBLY BODY**

LAB-78-4/38, 3/8" BSP, Alluminium Alloy, Mass 0,71 Kg

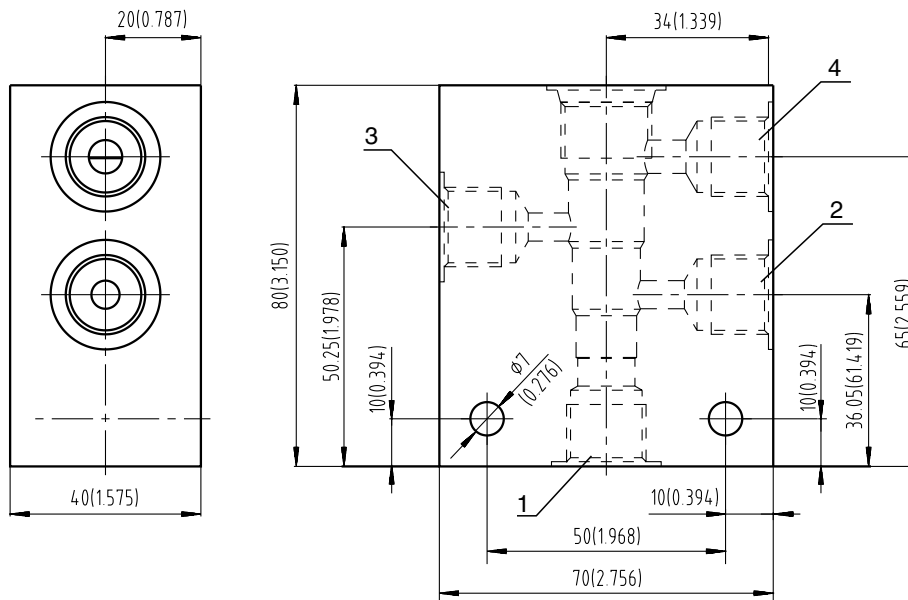



# SUMMARY



## **9** IN LINE CONTROL VALVES

IN LINE DIRECTIONAL CONTROL VALVES, CHECK VALVES

**FT257/6** 0001

---

PILOT OPERATED, CHECK VALVES

**FT257/7** 0002

---

SHUT-OFF VALVES

**FT221/1** 0003

---

SHUT-OFF VALVES

**FT29\*** 0004

---

FLOW CONTROL VALVES

**FT251/2-S** 0005

---

FLOW CONTROL VALVES

**FT1251/2-01** 0006

---

FLOW CONTROL VALVES

**FT251/5-S** 0007

---

FLOW CONTROL VALVES

**FT1251/5-01** 0008

---

**aidro**  
hydraulics



## IN LINE DIRECTIONAL CONTROL VALVES, CHECK VALVES

### FT257/6

32 MPa (320 bar)

#### 1 DESCRIPTION

Direct acting check valves, poppet type BSP thread ports for in-line assembly Body, poppet and spring in steel Maximum operating pressure: 320 bar Poppet release pressure: 0,35 bar (different settings available on request) Outer section for easier assembly with hexagonal spanner.



#### 2 ORDERING CODE

(1)					(2)
FT	257	/	6	-	

(1) FT257/6: check valve

(2) dimensions

- 14: Ports (Ø A) 1/4" BSP, Qmax 16l/min B 12,5 - C 63 - CH 22
- 38: Ports (Ø A) 3/8" BSP, Qmax 30l/min B 12,5 - C 69 - CH 27
- 12: Ports (Ø A) 1/2" BSP, Qmax 60l/min B 12,5 - C 80,5 - CH 32

(subject to technical and dimensional changes without notice)

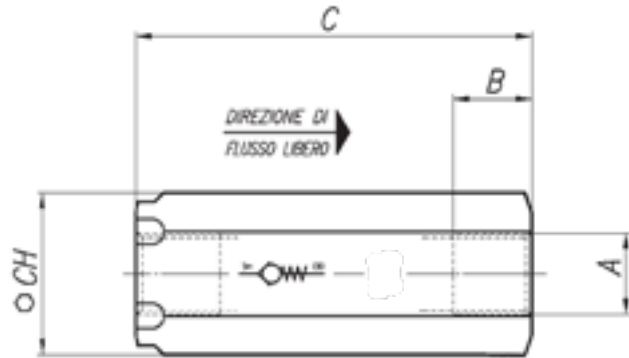

#### 3 TYPICAL DIAGRAMS

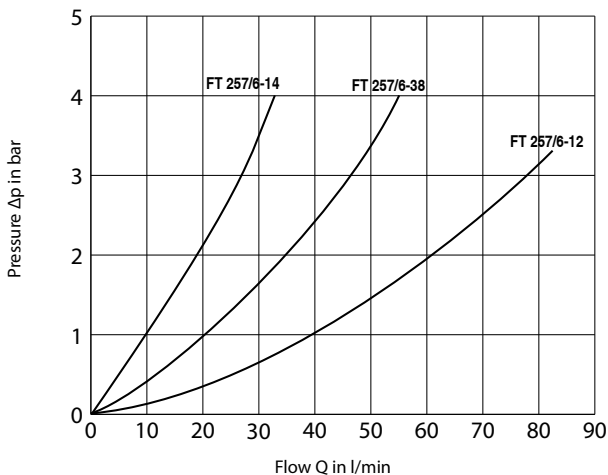

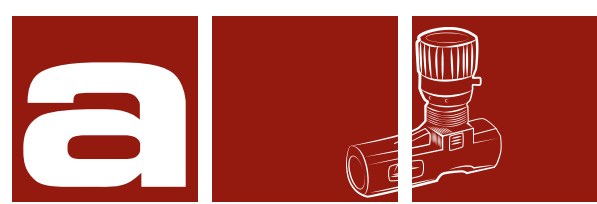

## PILOT OPERATED, CHECK VALVES

### FT257/7

32 MPa (320 bar)

#### 1 DESCRIPTION

Pilot operated check valves, poppet type BSP thread ports for in-line assembly Pilot port: 1/4" BSP Body, poppet and spring in steel. Maximum operating pressure: 320 bar. Outer section for easier assembly with hexagonal spanner.



#### 2 ORDERING CODE

(1)					(2)
FT	257	/	7	-	

(1) FT257/7: pilot operated check valve

(2) dimensions:

- 14: Ports (Ø A) 1/4" BSP, Qmax 16l/min- pilot ratio 1/5,3  
B 12,5 - D 100 - E 12 - CH 38 - CH1 28
- 38: Ports (Ø A) 3/8" BSP, Qmax 30l/min- pilot ratio 1/5  
B 12,5 - D 115 - E 12 - CH 41 - CH1 34
- 12: Ports (Ø A) 1/2" BSP, Qmax 60l/min- pilot ratio 1/5,3  
B 15,5 - D 139 - E 12 - CH 46 CH1 41

(subject to technical and dimensional changes without notice)

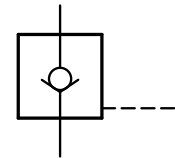

#### 3 TYPICAL DIAGRAMS

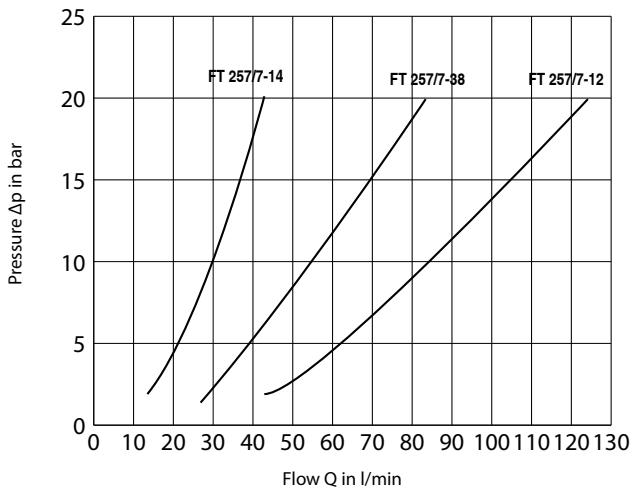

## SHUT-OFF VALVES

### FT221/1

50 MPa (500 bar)

#### 1 DESCRIPTION

Shut-off valves, ball type BSP thread ports for in-line assembly  
Body in steel. Lever and ball in chromium-plated steel Maximum  
pressure: 500 bar PTFE: ball seals



#### 2 ORDERING CODE

(1)					(2)
FT	221	/	1	-	

(1) FT221/1: shut-off valve

(2) dimensions:

14: Ports (Ø A) 1/4" BSP, Qmax 16l/min  
A 49 - B 71 - E 12,5 - F 110 ØL 5,5

38: Ports (Ø A) 3/8" BSP, Qmax 30l/min  
A 54 - B 72 - E 17,5 - F 110 ØL 5,5

12: Ports (Ø A) 1/2" BSP, Qmax 60l/min  
A 59 - B 83 - E 19 - F 110 - ØL 6,5

( subject to technical and dimensional changes without notice)

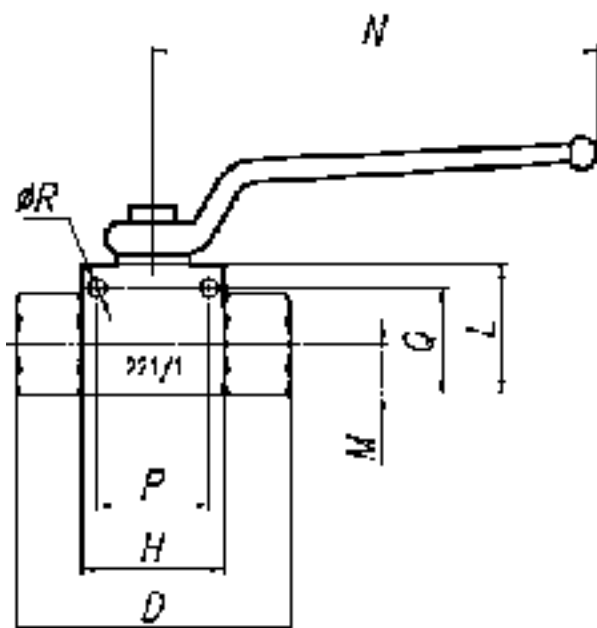

## SHUT-OFF VALVES

### FT29\*

40 MPa (400 bar)

#### 1 DESCRIPTION

Shut-off valves, needle type, typically used as shutter for pressure gauge 1/8" BSP thread ports for in-line assembly (male-female revolving) Body, in steel Maximum pressure: 400 bar Nitrile O-ring PTFE extrusion-safe ring



#### 2 ORDERING CODE

(1)		(2)
FT	29	

(1) FT29: shut-off valve

(2) orientation:

0: Ports 1/4" BSP, E 61,5 - L 45

1: Ports 1/4" BSP, E 30 - L 66

(subject to technical and dimensional changes without notice)



FT 291

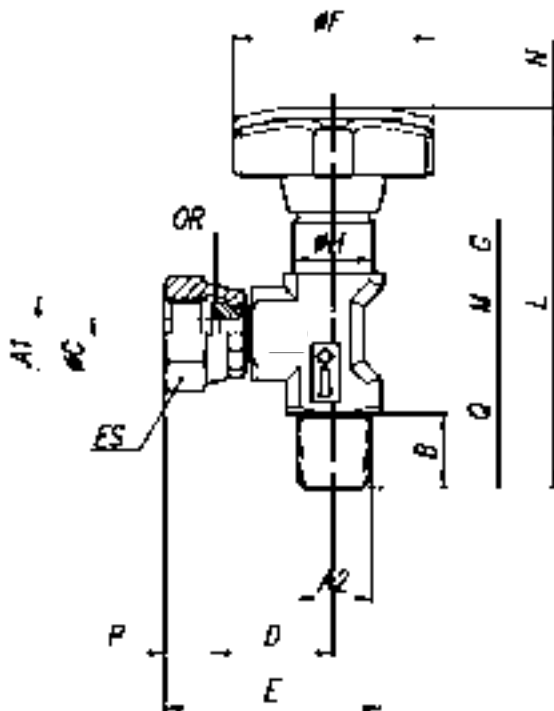

FT 290

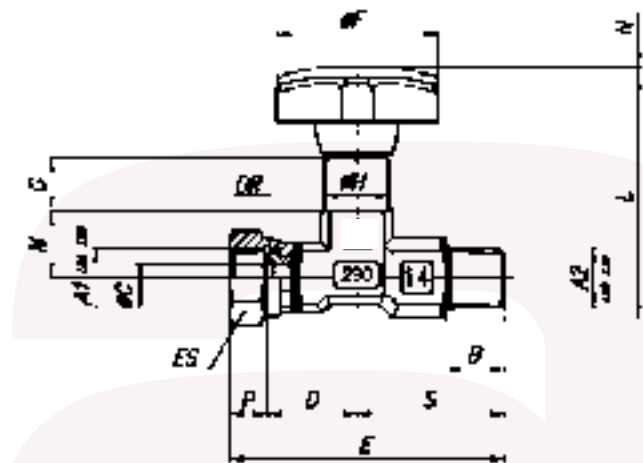

## FLOW CONTROL VALVES

### FT251/2-S

50 MPa (500 bar)

#### 1 DESCRIPTION

Flow control valves, needle type 2-way flow control, adjustable BSP thread ports for in-line assembly Steel body, poppet and spring in steel. Maximum operating pressure: 400 bar Adjustment hand-grip with locking screw



#### 2 ORDERING CODE

(1)					(2)	(3)
FT	251	/	2	-	S	-

(1) FT251/2: flow control valve needle type. Steel body

(2) S: special variant

(3) dimensions:

- 14: Ports 1/4" BSP, Qmax 16 l/min,  
A 46 - C 17 - E 12 - ØF 22 - H 61 - M 4,5
- 38: Ports 3/8" BSP, Qmax 30 l/min,  
A 55 - C 22 - E 13 - ØF 27 - H 74 - M 7
- 12: Ports 1/2" BSP, Qmax 60 l/min,  
A 70 - C 27 - E 16 - ØF 33 - H 85,5 - M 10

( subject to technical and dimensional changes without notice)

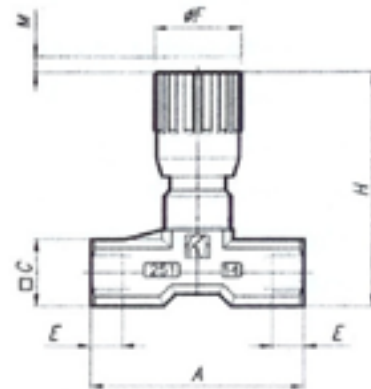

#### 3 TYPICAL DIAGRAMS

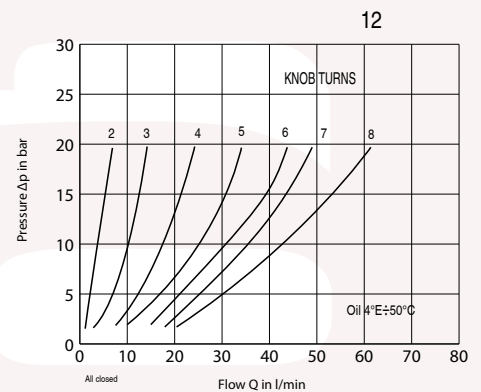
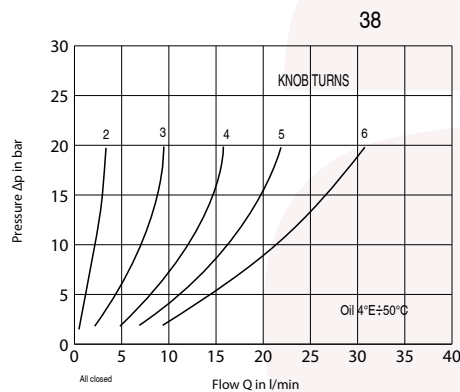
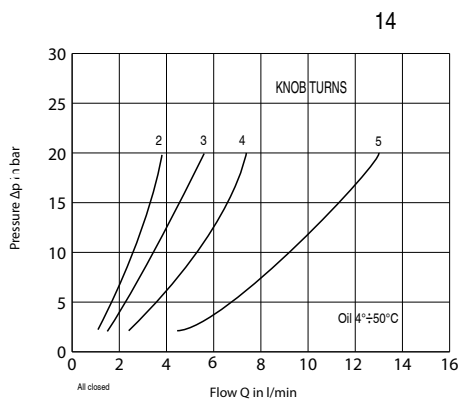





## FLOW CONTROL VALVES

### FT1251/2-01

21 MPa (210 bar)

#### 1 DESCRIPTION

Flow control valves, needle type 2-way flow control, adjustable.  
 BSP thread ports for in-line assembly. Brass body, poppet and spring in steel. Maximum operating pressure: 210 bar.  
 High adjustment accuracy due to its precision hand-grip with locking screw



#### 2 ORDERING CODE

(1)	(2)	(3)
FT 1251 / 2 - S -		

(1) FT1251/2: flow control valve needle type. Brass body

(2) S: special variant

(3) dimensions:

- 14: Ports 1/4" BSP, Qmax 16l/min,  
A 46 - C 17 - E 12 - ØF 22 - H 57 - M 4,5
- 38: Ports 3/8" BSP, Qmax 30l/min,  
A 55 - C 22 - E 13 - ØF 27 - H 69 - M 7
- 12: Ports 1/2" BSP, Qmax 60l/min,  
A 70 - C 27 - E 12 - ØF 33 - H 82 - M 10

( subject to technical and dimensional changes without notice)

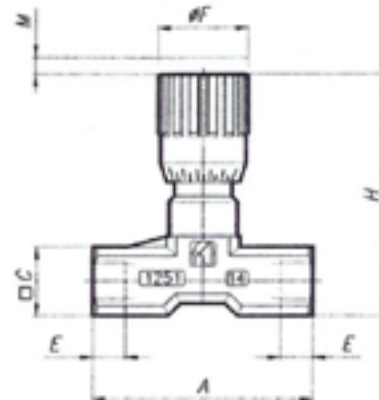

#### 3 TYPICAL DIAGRAMS

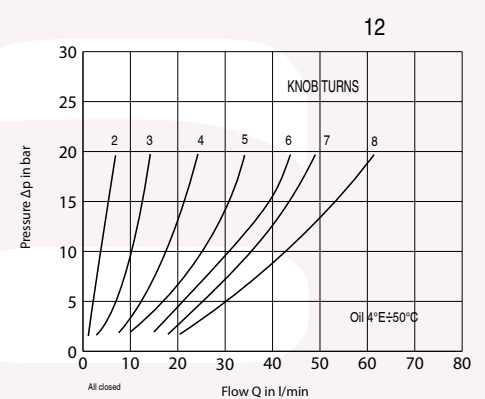
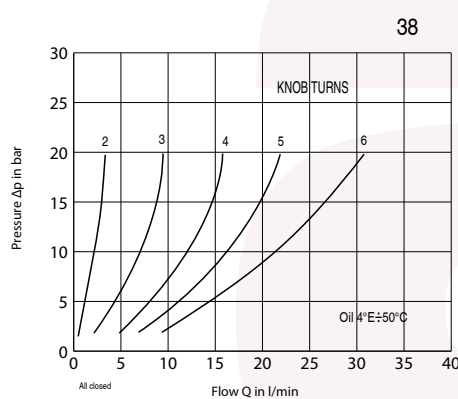
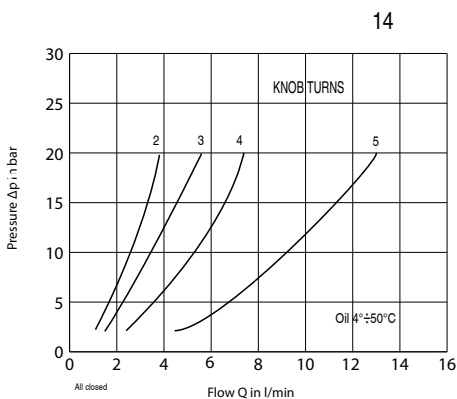

## FLOW CONTROL VALVES

### FT251/5-S

50 MPa (500 bar)

#### 1 DESCRIPTION

Flow control valves, needle type 1-way flow control, adjustable BSP thread ports for in-line assembly. Steel body, poppet and spring in steel. Maximum operating pressure: 400 bar Adjustment hand-grip with locking screw



#### 2 ORDERING CODE

(1)					(2)		(3)
FT	251	/	5	-	S	-	

(1) FT251/5: 1 way flow control valve needle type, steel body

(2) S: special variant

(3) dimensions:

- 14: Ports 1/4" BSP, Qmax 16 l/min,  
A 56 - C 17 - E 12 - ØF 22 - H 61 - M 4,5
- 38: Ports 3/8" BSP, Qmax 30 l/min,  
A 64,5 - C 22 - E 13 - ØF 27 - H 74 - M 7
- 12: Ports 1/2" BSP, Qmax 60 l/min,  
A 87 - C 27 - E 16 - ØF 33 - H 85,5 - M 10

( subject to technical and dimensional changes without notice)

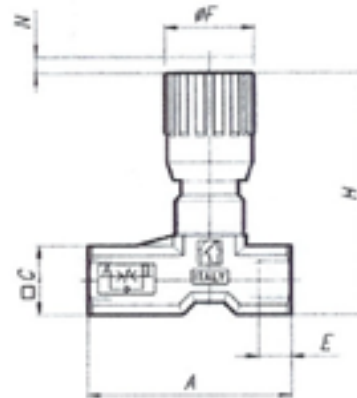
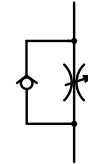

#### 3 TYPICAL DIAGRAMS

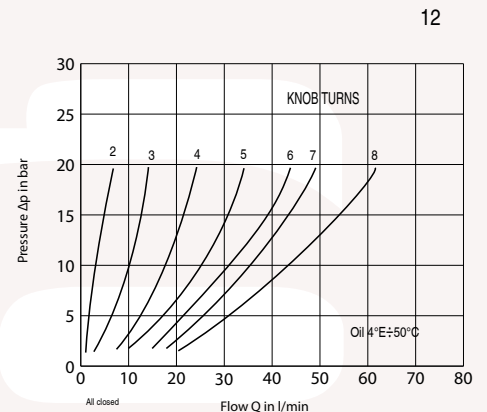
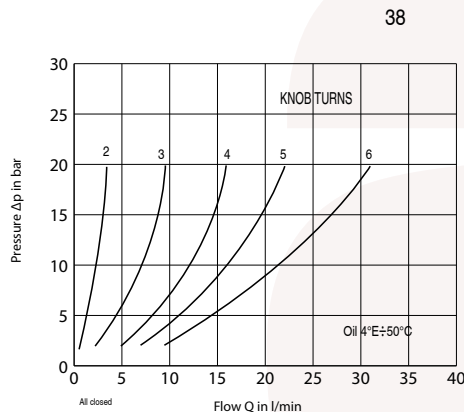
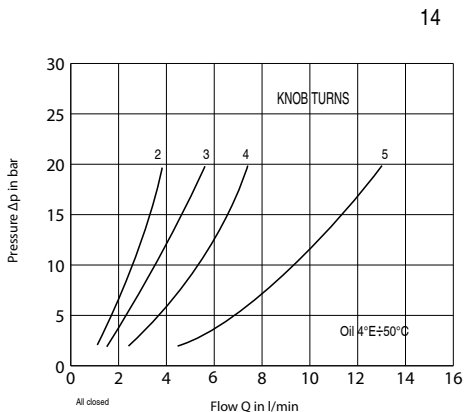

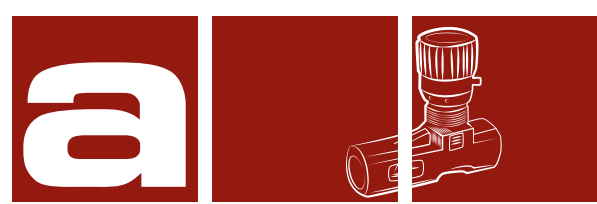

## FLOW CONTROL VALVES

### FT1251/5-01

21 MPa (210 bar)

#### 1 DESCRIPTION

Flow control valves, needle type 1-way flow control, adjustable. BSP thread ports for in-line assembly. Brass body, poppet and spring in steel  
 Maximum operating pressure: 210 bar. High adjustment accuracy due to its precision hand-grip with locking screw



#### 2 ORDERING CODE

(1)					(2)		(3)
FT	1251	/	5	-	S	-	

(1) FT251/5: 1 way flow control valve needle type, brass body

(2) S: special variant

(3) dimensions:

- 14: Ports 1/4" BSP, Qmax 16 l/min,  
A 56 - C 17 - E 12 - ØF 22 - H 61 - M 4,5
- 38: Ports 3/8" BSP, Qmax 30 l/min,  
A 64,5 - C 22 - E 13 - ØF 27 - H 74 - M 7
- 12: Ports 1/2" BSP, Qmax 60 l/min,  
A 87 - C 27 - E 16 - ØF 33 - H 85,5 - M 10

(subject to technical and dimensional changes without notice)

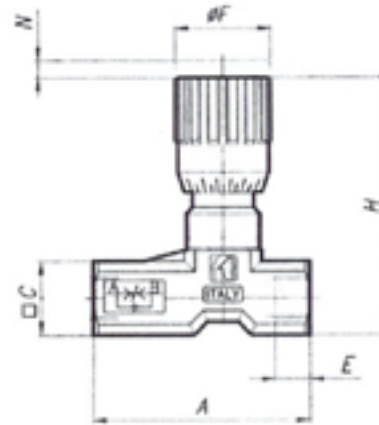
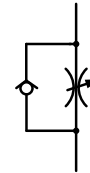

#### 3 TYPICAL DIAGRAMS

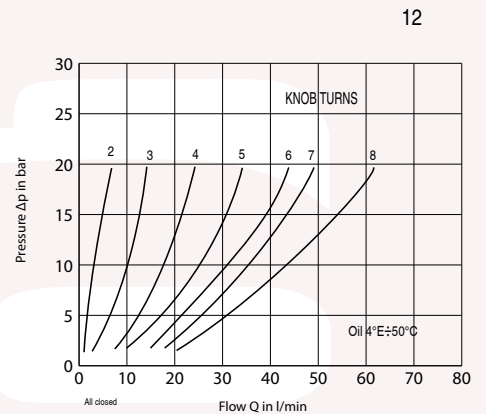
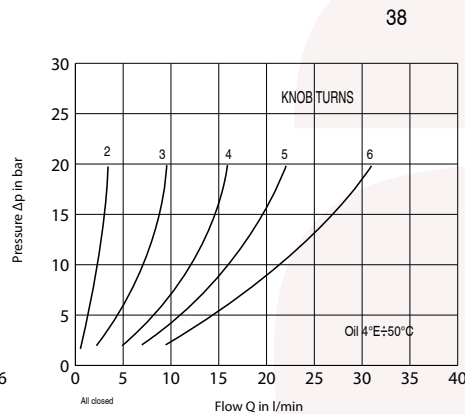
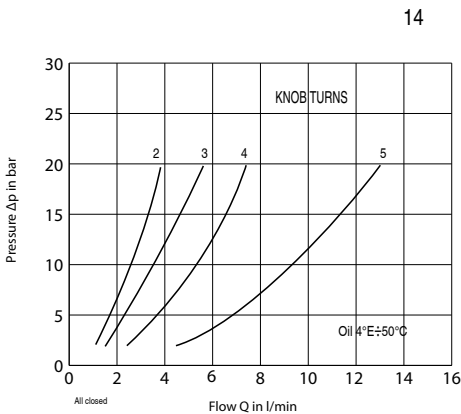



# SUMMARY



## **10** VARIOUS SCREW IN CARTRIDGE AND MODULES

MAXIMUM PRESSURE VALVE DIRECT-ACTING

**MO-2/\*\***

0001

---

SCREW-IN CARTRIDGE DIRECT-ACTING RELIEF VALVE

**MO-3/\***

0002

---

FLOW CONTROL VALVE TYPE

**FT243/5-38**

0004

---

PRESSURE SWITCHES

**IP\*-.\*\***

0005

---

**aidro**  
hydraulics





## MAXIMUM PRESSURE VALVE DIRECT-ACTING

### MO-2/\*\*

30 l/min 35 MPa (350 bar)

#### 1 DESCRIPTION

MO-2 is a direct operated pressure relief valve in a special cavity 3/4" 16UNF but with larger nose thus with better performances. The external surface is zinc coated. There are three different pressure settings for a more accurate regulation.



#### 2 ORDERING CODE

(1)		(2)		(3)
MO	-	2	/	

(1) MO: pressure valve

(2) 2: nominal size

(3) Pressure ranges:

10: min-max operating pressure 20-130bar, 16,5 l/min

20: min-max operating pressure 40-220bar, 25,5 l/min

32: min-max operating pressure 60-350bar, 51 l/min

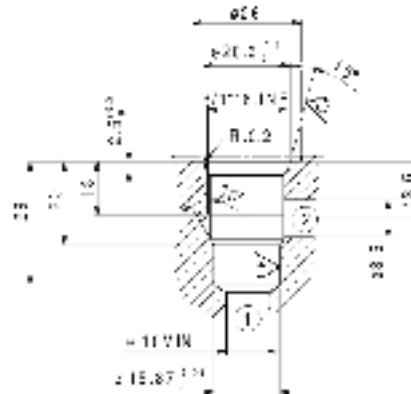
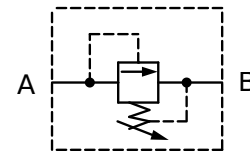

#### 3 TECHNICAL DATA

Maximum nominal pressure	35 MPa 350 bar
Maximum rec. flow rate	30 l/min
Mass	0,13 Kg

#### 4 TYPICAL DIAGRAMS

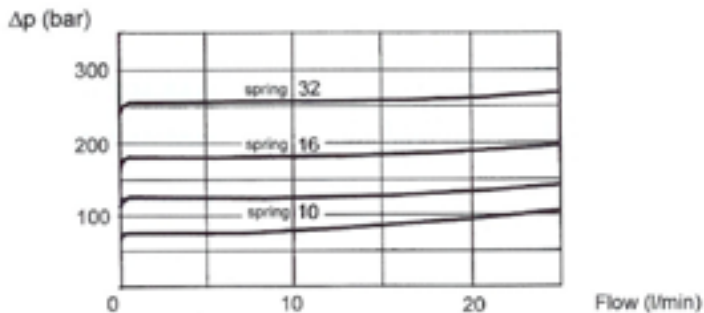

#### 5 INSTALLATION DIMENSIONS

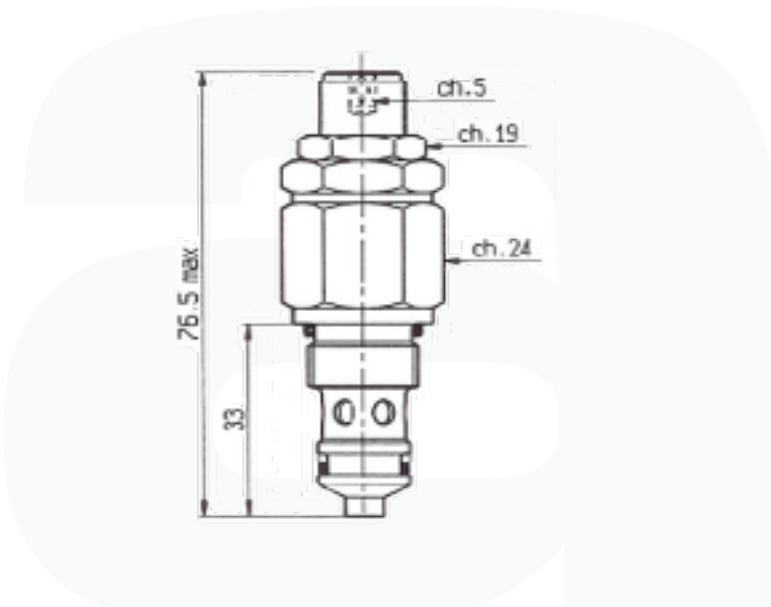

## SCREW-IN CARTRIDGE DIRECT-ACTING RELIEF VALVE

### MO-3/\*

30 l/min 35 MPa (350 bar)

#### 1 DESCRIPTION

MO-3 is a direct operated pressure relief valve in a special metric cavity M20x1,5.

The external surface is zinc coated.

There are three different pressure settings for a more accurate regulation.

The valve is designed with an anti vibration system



#### 2 ORDERING CODE

(1)	(2)	(3)	(4)	(5)	(6)		
MO	-	3	/	-	-	/	01

(1) MO: screw-in cartridge relief valve

(2) 3: nominal size  
nominal flow rate = 0,5 dm<sup>3</sup>/s (approx 32 l/min)

(3) Pressure adjustment ranges:  
10: from 2,5 MPa to 12,5 MPa ( from 25 to 125 bar)  
20: from 2 MPa to 25 MPa (from 40 to 250 bar)  
32: from 10 MPa to 32 MPa (from 100 to 320 bar)

(4) code reserved for variants to the adjustment (knob, handwheel, etc.)

(5) code reserved for special variants (materials, seals, surface treatments etc.)

(6) 01: Design number (progressive) of the valve

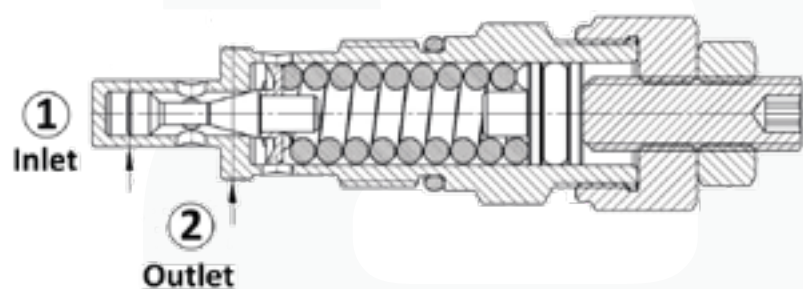
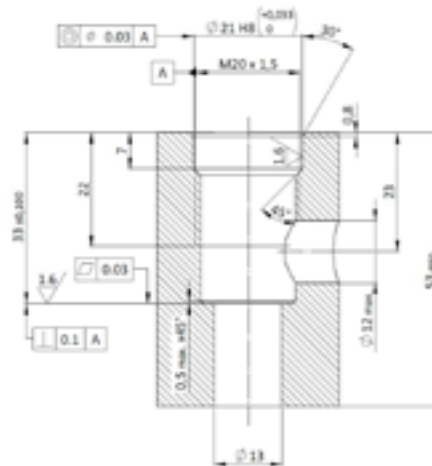
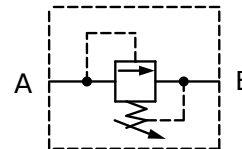

### 3 TECHNICAL DATA

Maximum pressure range	see 2	Adjustement of the relief pressure:
Maximum rec. flow rate	40 l/min	relief pressure is reached when the axial hydraulic forces on piston 3 equal the force of spring 5; the value of the relief pressure can be therefore changed, within the limits of the chosen adjustment range, by changing the compression of spring 5. to increase the relief pressure, turn clock wise the adjustment screw 4 after having unlocked ist nut 6. Fore each pressure adjustment range, the pressure gradient is approx: M0-3/10: 1,6 MPa/mm ( 24 bar/turn)
Nominal flow rate	32 l/min	M0-3/20: 3,2 MPa/mm ( 48 bar/turn)
Pressure relief curves	see 4	M0-3/32: 5 MPa/mm ( 75 bar/turn)
installation and dimensions	see 5	when the required level of pressure is reached, lock the nut6.
mass	appron 0,17	Valve type M0-3/* are normally factory tested and settled, with Q=0,1 dm3/s (6 l/min) at the following pressures. M0-3/10: 10 MPa (100bar) ( ±10% ) M0-3/20: 20 MPa (200bar) ( ±10% ) M0-3/ 32: 32 MPa (320bar) ( ±5% )

### 4 TYPICAL DIAGRAMS

Typical curves for valves M0-3/\* in standard configuration, with mineral oil at 36 cSt a 50°C

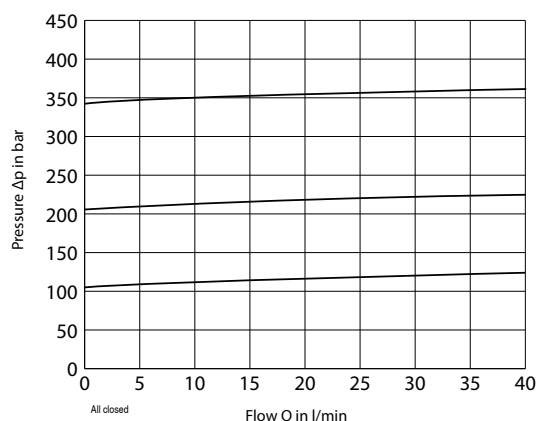

### 5 INSTALLATION DIMENSIONS

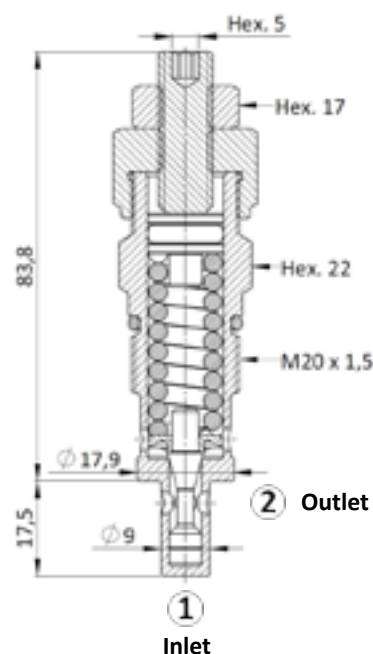

### 6 HYDRAULIC FLUIDS

Seals and materials used on standard valves are fully compatible with hydraulic fluids of mineral oil base, upgraded with antifoaming and antioxidizing agents. The hydraulic fluid must be kept clean and filtered to ISO 4406 class 19/17/14, or better, and used in a recommended viscosity range from 10 cSt to 60 cSt.

Cartridge valves type M0-3/\* must be installed in exactly machined cavities obtained in metallic bodies of strenght suitable to sustain the hydraulic efforts. When installing the valve care must be paid not to damage seal ( OR 121-15,88x2,62-70 Sh ) and to screw-in the valve by applying the appropriate torque of approx. 60Nm to the exagonal CH 22.



## FLOW CONTROL VALVE TYPE

### FT243/5-38

20 l/min 25 MPa (250 bar)

#### 1 DESCRIPTION

Those valves are to be mounted in very simple cavities M18x1 (see drawing) and give free flow in one direction and adjustable controlled flow on the reverse direction.



#### 2 ORDERING CODE

(1)					
FT	243	/	5	-	38

(1) FT243/5: 1 way flow control valve needle type

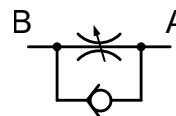

(subject to technical and dimensional changes without notice)

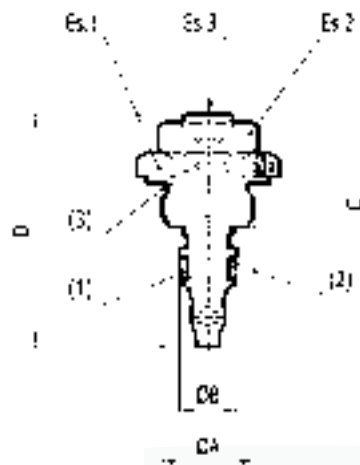
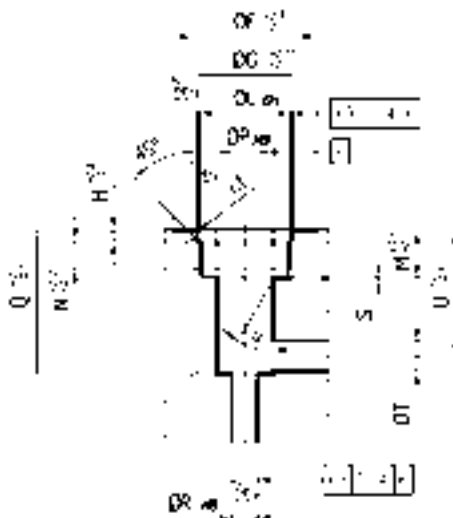

#### 3 TYPICAL DIAGRAMS

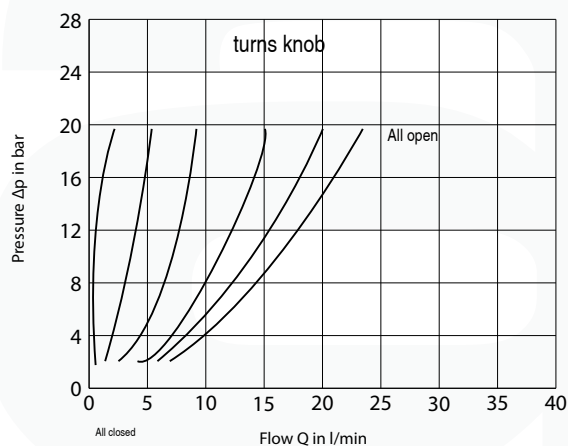
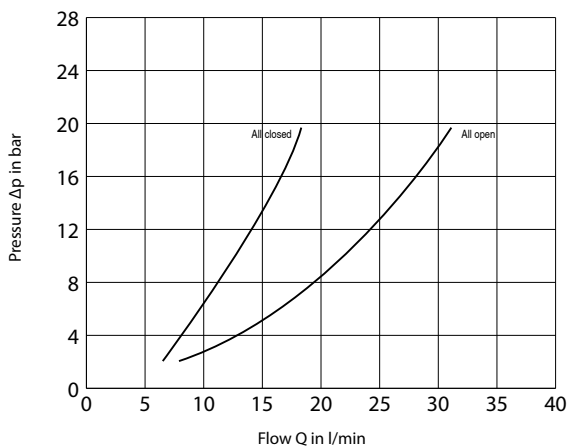

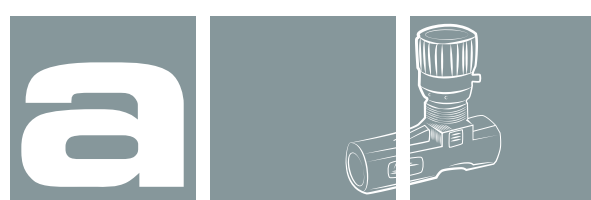

## PRESSURE SWITCHES

IP\*.-\*\*

### 1 DESCRIPTION

Pressure switches



### 2 ORDERING CODE

(1)	(2)	(3)	(4)
IP	- 2	-	/

(1) IP : pressure switch

(2) Type of setting adjustment  
 2 : grub screw (see 3)  
 3 : scaled handweel (see 2)

(3) Pressure range  
 3,2 : 6-35 bar (0,6 - 3,5 MPa)  
 16 : 12-160 bar (1,2 - 16,0 MPa)  
 32 : 30-350 bar (3,0 - 35,0 MPa)  
 63 : 50-630 bar (5,0 - 63,0 MPa)

(4) Electrical connection  
 no designation : standard  
 A : optional

SYMBOL



CONTACTS

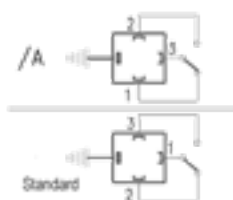

FLANGE INTERFACE

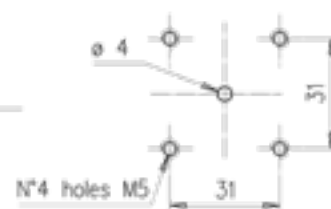

### 3 TECHNICAL SPECIFICATION FOR PRESSURE SWITCH TYPE IP3

Weight: 0,65 Kg  
 Maximum error <math>\leq \pm 1\%</math> of setting  
 Protection: IP-65

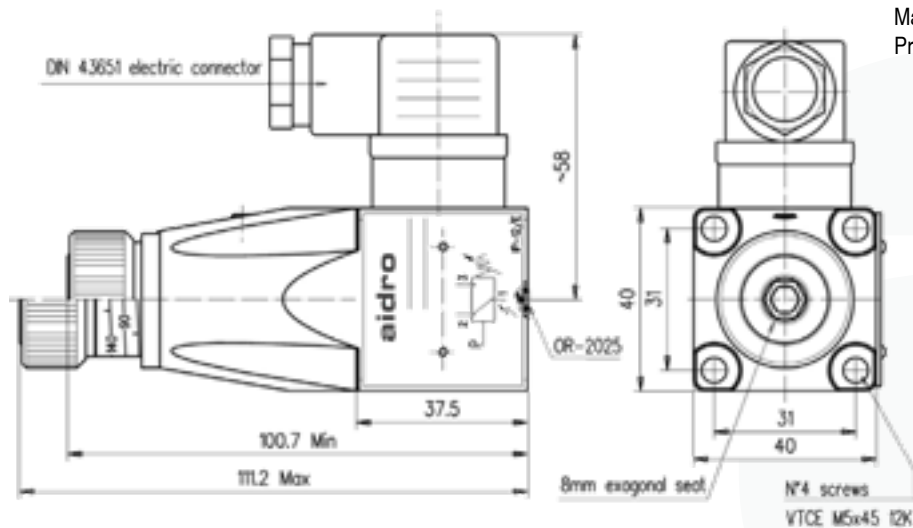

## 4 TYPICAL DIAGRAMS FOR IP3

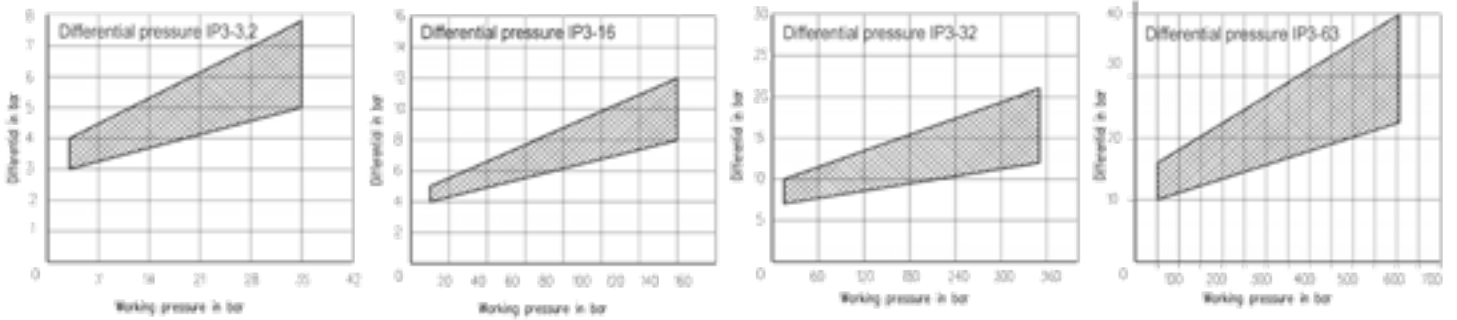

## 5 TECHNICAL SPECIFICATION FOR PRESSURE SWITCH TYPE IP2

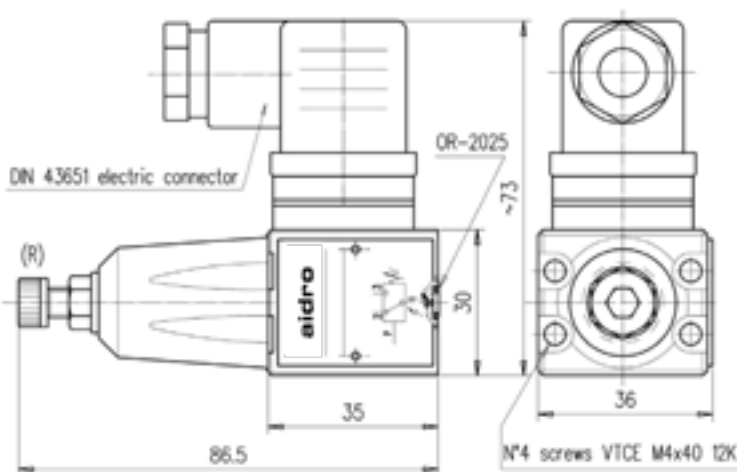

SYMBOL

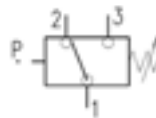

CONTACTS

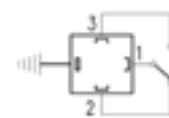

FLANGE INTERFACE

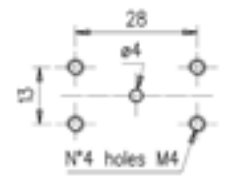

Weight: 0,35 Kg  
Maximum error  $<\pm 1\%$  of setting  
Protection: IP-65

## 6 TYPICAL DIAGRAMS FOR IP2

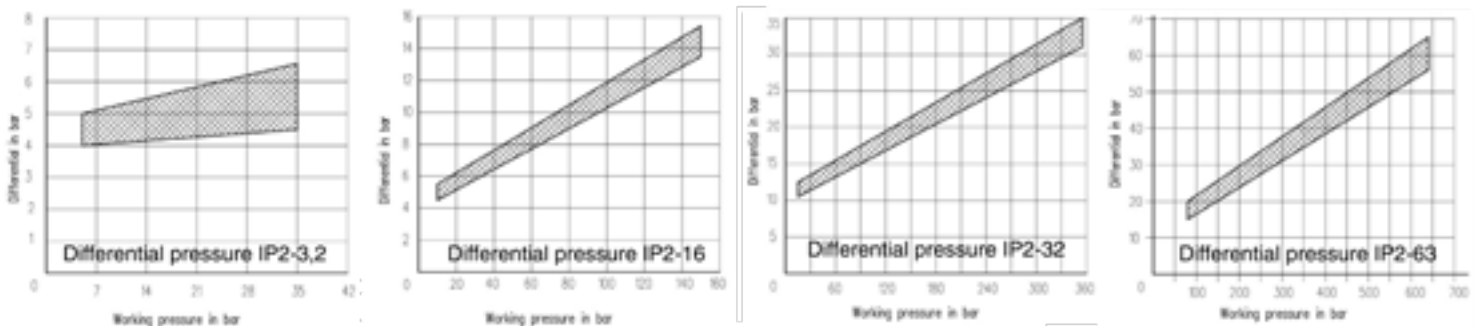

## 7 ADAPTORS FOR PANEL MOUNTING

APM-14

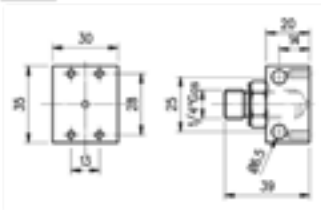

It allows the pressure switch mounting:  
- panel-mounted adaptor by using n.2 ø 6.5 holes  
- equipped with 1/4" BSP nipple

APH-14

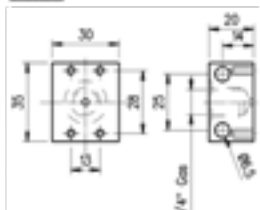

It allows the pressure switch mounting: panel-mounted adaptor by using n.2 ø 6.5 holes.

BEU-14 (Female adaptor)

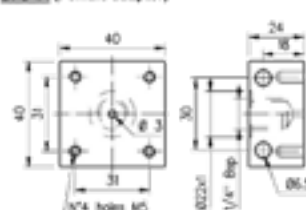

WEIGHT 0.3 Kg.

BMM-14

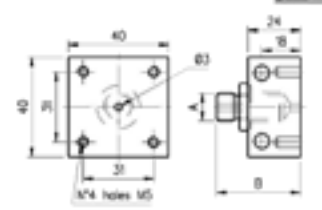

TYPE	A	B	WEIGHT
BMM-14	1/4" BSP	41	0.3 Kg.
BMM-38	3/8" BSP	45	
BMM-12	1/2" BSP	46	

## 8 TECHNICAL DATA

	125 AC	250 AC	30 DC	150 DC
Max voltage (rated load)	7 Amp	5 Amp.	5 Amp.	0,2 Amp
Connection frequency	Max. 120 cycles/min			
Protection	IP-65			
Direct current with inductive load	it is suggested to provide an arching contact			

## 9 CETOP MOUNTING MODULES

CETOP 02

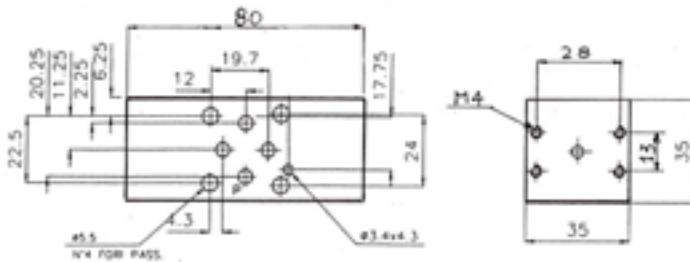

CETOP 03

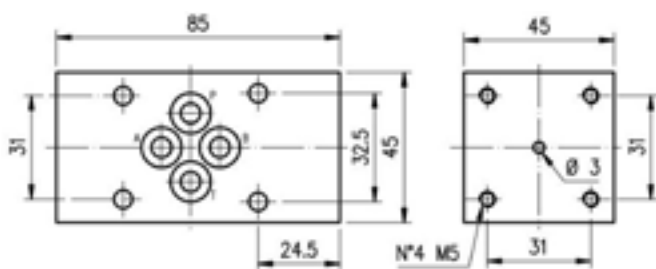

CETOP 05

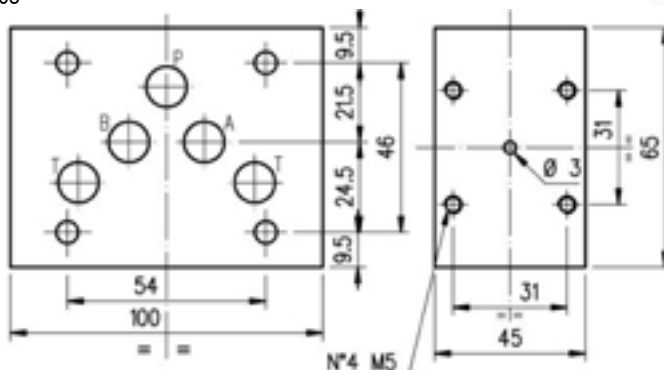

Example of ordering code: AM3-KO-AB/16  
where:

AM3-KO=CETOP 03 module  
AB= Pressure switch on lines A and B  
/16= pressure range





# SUMMARY



## **11** POWER PACK

4/2 and 4/3 DIRECTIONAL CONTROL VALVES PILOT OPERATED

**ASMC**

0001

---

---

---

---

---

---

---

---

**aidro**  
hydraulics



## Mini Power Pack

### ASMC

15 l/min 20 MPa (200 bar)

#### 1 DESCRIPTION

ASMC are compact power packs designed in order to be flexible and configurable following the hydraulic scheme of the final application.

It is based on the HDF valve series and because of that, it is possible to configure many different functions, with directional valves, pressure and flow control, hand pumps and so on. It is possible to have the power pack with AC or DC motors with different power limits.

On demand is possible to have plastic tanks and also custom configurations. For this special request please ask to our technical department.

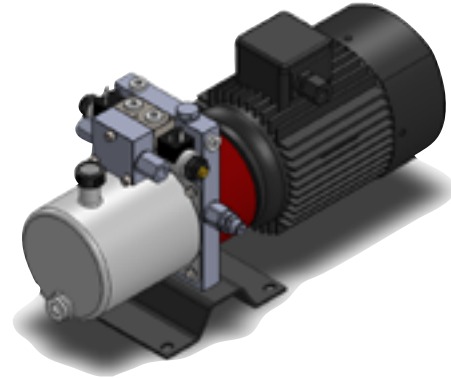

#### 2 ORDERING CODE

(1)	(2)	(3)	(4)	(5)
ASMC	-	-	-	/ *

See some examples of combinations and possible hydraulic circuits assembled with Aidro HDF valves

(1) ASMC: Aidro small power pack

(2) Tank Nominal capacity:

02 = 2 l (dm<sup>3</sup>)

04 = 4 l (dm<sup>3</sup>)

08 = 8 l (dm<sup>3</sup>)

10 = 10 l (dm<sup>3</sup>)

(3) Pump code = displacement:

08 = 0,8 cm<sup>3</sup>/rev

12 = 1,2 cm<sup>3</sup>/rev

16 = 1,6 cm<sup>3</sup>/rev

25 = 2,5 cm<sup>3</sup>/rev

36 = 3,6 cm<sup>3</sup>/rev

44 = 4,4 cm<sup>3</sup>/rev

58 = 5,8 cm<sup>3</sup>/rev

(4) Engine code = combination electric motor/installed power (see 4):

055AC3 = 0,55 kW and Three Phase 400V AC

075AC3 = 0,75 kW and Three Phase 400V AC

110AC3 = 1,10 kW and Three Phase 400V AC

055AC1 = 0,55 kW and Mono Phase 230V AC

075AC1 = 0,75 kW and Mono Phase 230V AC

110AC1 = 1,10 kW and Mono Phase 230V AC

120DC24 = 1,20 kW and Direct current 24V DC

150DC12 = 1,50 kW and Direct current 12V DC

200DC24 = 2,00 kW and Direct current 24V DC

(5) Options: code reserved for identification of the specific hydraulic scheme of the customer

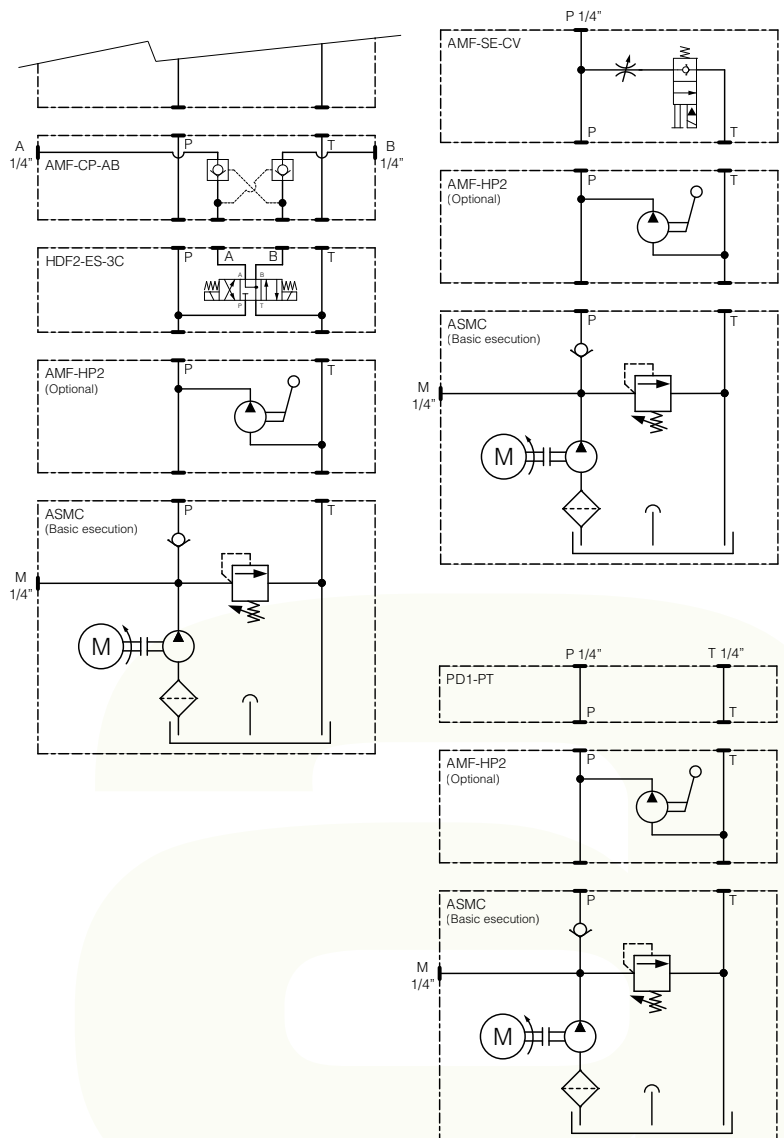



### 3 TECHNICAL DATA

Protection class motors	IP 55F for AC motors ; IP 43 F for DC motors
Ports	A,B : G 1/4"
Fluids	Hydraulic oils (HL, HLP) to DIN 51524 Oil
Recommended viscosity	20 .. 100 mm <sup>2</sup> /s
Fluid contamination class	Class 21/18/15 according to ISO 4406 (1999)
Fluid temperature	0 .. +70 °C
Ambient temperature	-25 .. +50 °C

### 4 COMBINATIONS ELECTRIC MOTOR / INSTALLED POWER

Engine Power	Motor Type	AC3 [400V]		AC1 [230/50Hz]		DC12 [12V]		DC24 [24V]	
		Power	RPM	Power	RPM	Power	RPM	Power	RPM
055		0,55 kW	1390 rpm	0,55 kW	1370 rpm				
075		0,75 kW 1400 rpm	0,75 kW 2850 rpm	0,75 kW 1410 rpm	0,75 kW 2820 rpm				
110		1,10 kW 2850 rpm		1,10 kW 2845 rpm					
120								1,2 kW 3200 rpm	
150						1,50 kW 2400 rpm			
200								2,0 kW 2100 rpm	

To define the engine code it is necessary combine the installed power with the electric motor.

### 5 COMBINATIONS MOTOR / PUMP for AC motors

Power pack	Tank nominal capacity ( 2,4,8,10 l )	Pump code	ENGINE CODE															
			055AC3 1390 rpm		075AC3 1400 rpm		075AC3 2850 rpm		110AC3 2850 rpm		055AC1 1370 rpm		075AC1 1410 rpm		075AC1 2820 rpm		110AC1 2845 rpm	
			bar	l/min	bar	l/min	bar	l/min	bar	l/min	bar	l/min	bar	l/min	bar	l/min	bar	l/min
ASMC		08	200	0,9			180	1,9	200	1,9	200	0,9			185	1,9	200	1,9
ASMC		12	180	1,4	200	1,4	120	2,9	175	2,9	180	1,4	200	1,5	120	2,9	175	2,9
ASMC		16	135	1,9	180	1,9	90	4,0	130	4,0	135	1,9	180	2,0	90	3,9	130	4,0
ASMC		25	85	3,2	115	3,2	55	6,5	80	6,5	85	3,1	115	3,2	55	6,4	85	6,5
ASMC		36	60	4,6	80	4,6	40	9,4	60	9,4	60	4,6	80	4,7	40	9,3	60	9,4
ASMC		44	50	5,6	65	5,7	30	11,5	45	11,5	50	5,6	65	5,7	35	11,4	50	11,5
ASMC		58	35	7,4	50	7,5	25	15,2	35	15,2	35	7,4	50	7,5	25	15,0	35	15,1

The nominal pressure is the maximum working pressure allowed without time limit.

The maximum pressure is the maximum permissible pressure for a short period of time ( max time is 20 sec ):

250 bar= Maximum pressure for all pumps, except for pump code 58 which maximum pressure is 200 bar

Example of power pack code: type ASMC, tank by 10 l, pump 2,5 cm<sup>3</sup>/rev, engine power 0,55 Kw 400V AC = ASMC-10-25-055AC3

## 6 COMBINATIONS MOTOR / PUMP for DC motors

Power pack	Tank nominal capacity	Pump code	ENGINE CODE					
			120DC24 3200 rpm		150DC12 2400 rpm		200DC24 2100 rpm	
			bar	l/min	bar	l/min	bar	l/min
ASMC	2-10 l	08-58	0-200	2-16	0-200	3-16	0-200	3-16

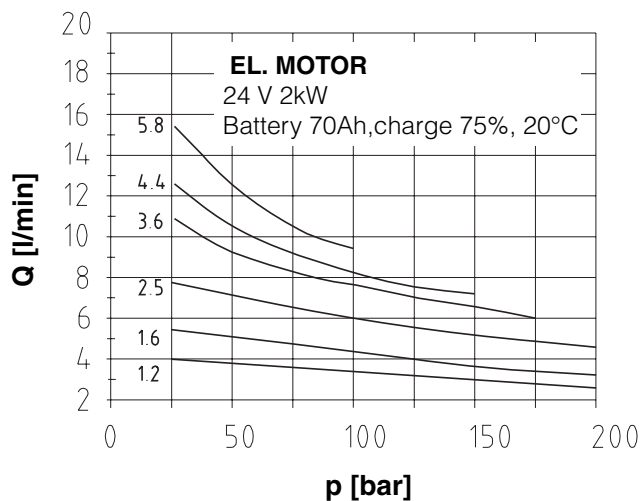
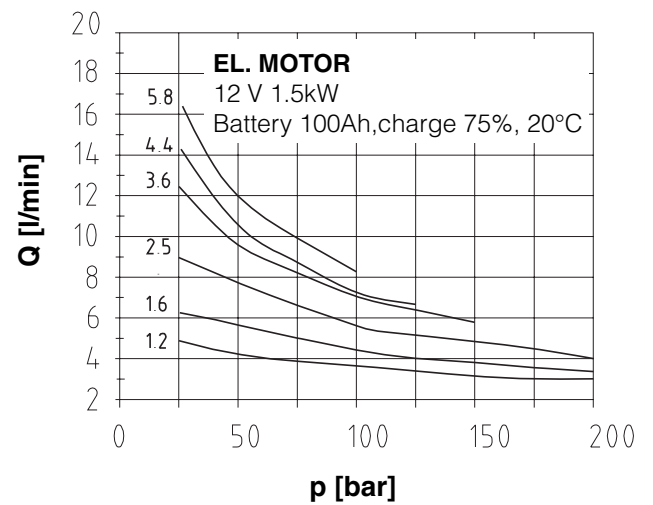
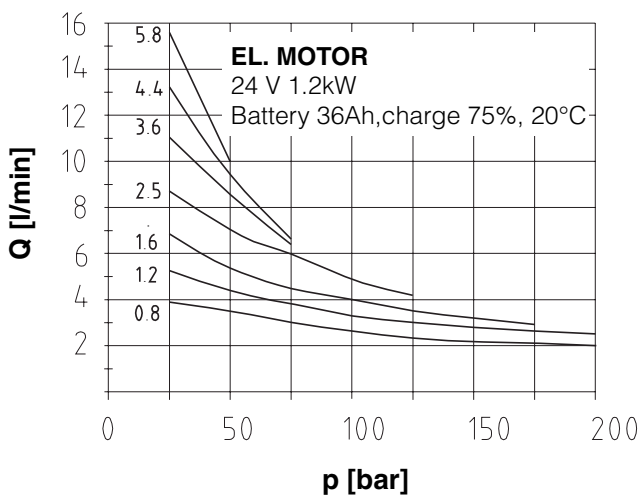

Example of power pack code: type ASMC, tank of 8 l, Pump 1,2 cm<sup>3</sup>/rev, engine power 1,5 Kw 12V DC = ASMC-08-12-150DC12

**7 INSTALLATION DIMENSIONS POWER PACK with AC motor**

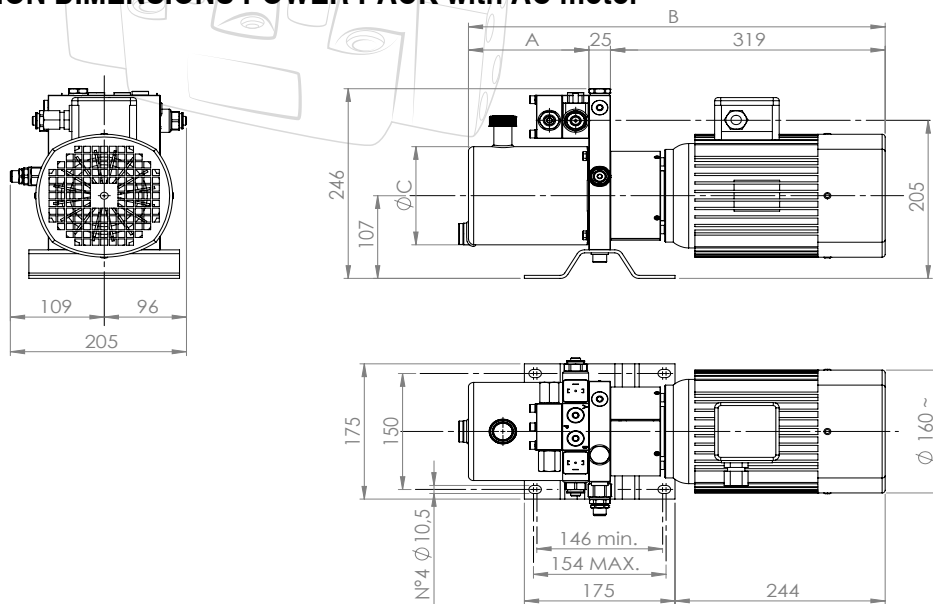

Power Pack	A	B	C
ASMC-02	~240	~584	ø127
ASMC-04	~400	~744	ø127
ASMC-08	~350	~694	ø183
ASMC-10	~430	~774	ø183

**8 INSTALLATION DIMENSIONS POWER PACK with 120DC24 motor**

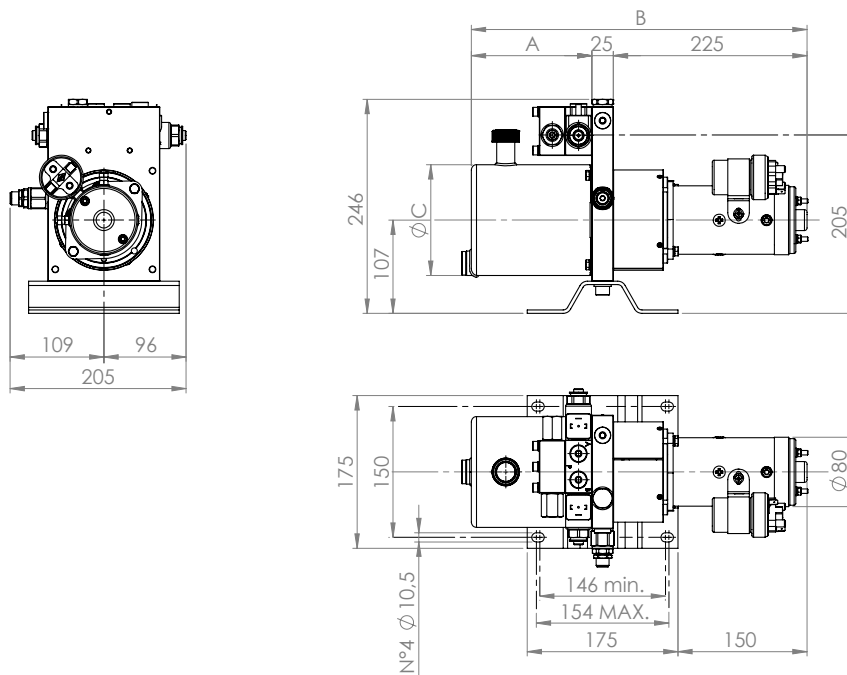

Power Pack	A	B	C
ASMC-02	~240	~490	ø127
ASMC-04	~400	~650	ø127

**9 INSTALLATION DIMENSIONS POWER PACK with 150DC12 - 200DC24 motor**

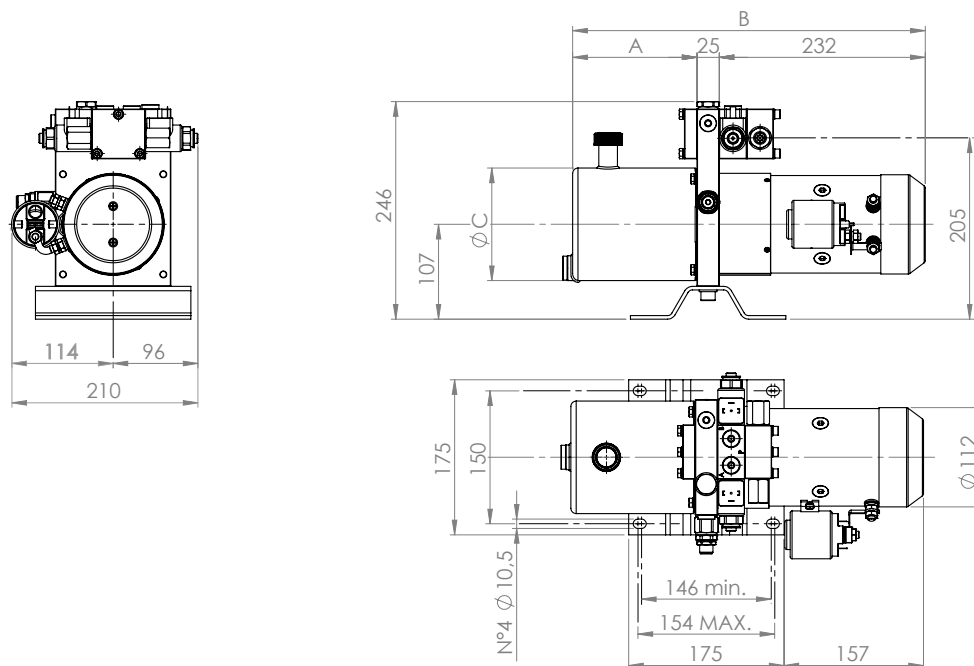

Power Pack	A	B	C
ASMC-04	~400	~657	ø127
ASMC-08	~350	~607	ø183
ASMC-10	~430	~687	ø183

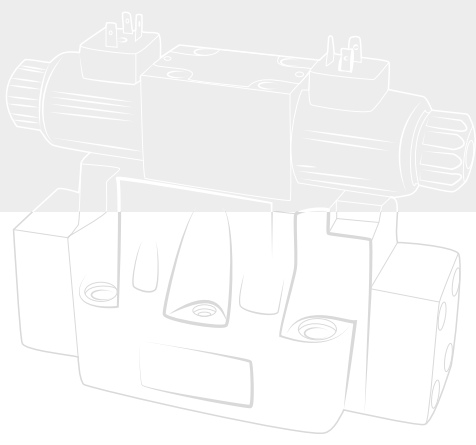



# SUMMARY

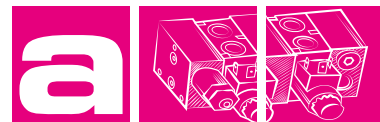

## 12 VARIOUS

DIAPHRAGM PRESSURE SWITCH WITH SETTING SCREW

**A-573-\*** 0001

---

PRESSURE SWITCH WITH SETTING SCREW

**A-P27HP-\*** 0002

---

SEQUENCE VALVE POPPET TYPE in line mounting type

**CPR-LG38/\*** 0003

---

ANTI CAVITATION VALVE POPPET TYPE METRIC CAVITY M18X1,5

**CPR-M18 /\*** 0004

---

HYBRID SAE CARTRIDGE POPPET TYPE

**EVMD.78.04\*\*** 0006

---

GAS CARTRIDGE-DIRECT ACTING-BALL TYPE

**CVG14** 0008

---

**aidro**  
hydraulics



## DIAPHRAGM PRESSURE SWITCH WITH SETTING SCREW A-573-\*

### 1 DESCRIPTION

Screw in diaphragm pressure switch with setting screw.  
The body is in steel zinc plated and it is available with different pressure ranges and settings.  
A rubber cover cup protects the electric contacts.



### 2 ORDERING CODE

(1)	(2)	(3)	(4)	(5)	(6)
A-573	-				

(1) A-573: diaphragm pressure switch

(2) Regulation setting:

1:	0,2 - 1 bar
2:	0,5 - 2 bar
10:	1 - 10 bar
20:	10 - 20 bar
50:	20 - 50 bar
200:	50 - 200 bar
300:	20 - 300 bar

(3) preset at:

59 bar  
120 bar

(4) Type of contact

NO: Normally open  
NC: Normally closed

(5) Thread:

G18: G1/8"  
G14: G1/4"

(6) Code reserved for special variants

O: Additional o-ring and body with o-ring groove  
D: pressure setting when system pressure falling  
U: pressure setting when system pressure rising

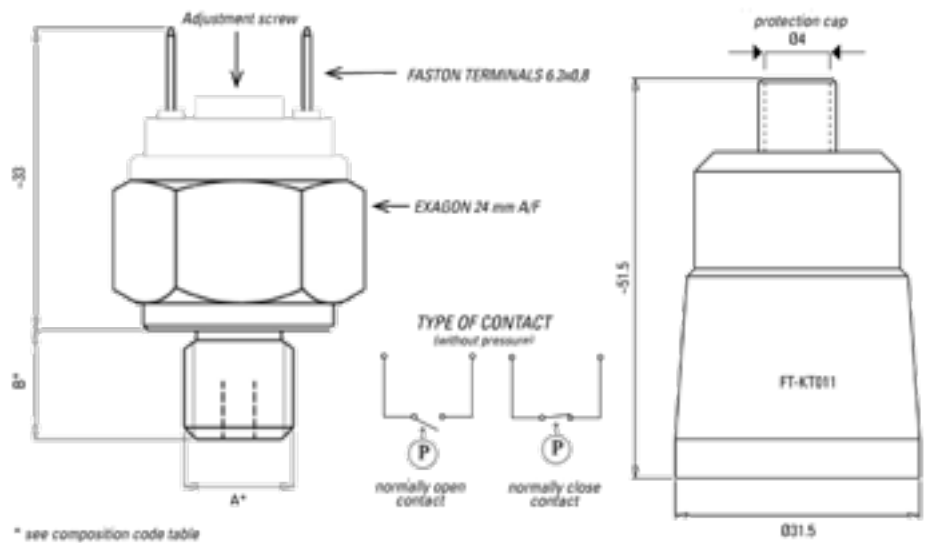

### 3 TECHNICAL DATA

Max current	36V - 0,5 Amp
Maximum pressure	250 bar (25 MPa)
Protection	IP64 with rubber cover cap
Mechanical life	10 <sup>6</sup> cycles
Diaphragm	NBR
Body	Zinc plated steel



## PRESSURE SWITCH WITH SETTING SCREW A-P27HP-\*

### 1 DESCRIPTION

Screw in diaphragm pressure switch with setting screw.  
The body is in steel zinc plated and it is available with different pressure ranges and settings.  
The electrical connection is assured by a DIN connector with an IP65 protection degree.



### 2 ORDERING CODE

(1)	(2)	(3)	(4)	(5)
A-P27HP	-			/

- (1) A-P27HP:  
piston pressure switch
- (2) regulation setting  
50:20 - 50 bar  
300:20 - 300 bar
- (3) Type of contact  
NO:Normally open  
NC:Normally closed
- (4) Thread:  
G18:G1/8"  
G14:G1/4"
- (5) Code reserved for special variants

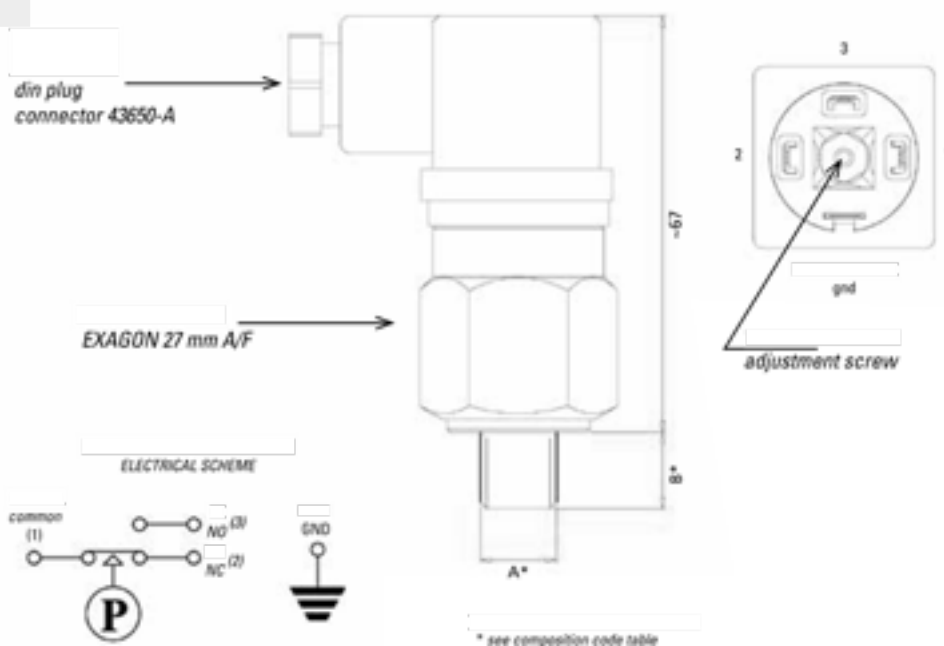

### 3 TECHNICAL DATA

Max current	250 V DC - 0,5 Amp
Maximum pressure	600 bar (60 MPa)
Protection	IP65
Mechanical life	10 <sup>6</sup> cycles
Piston	steel
Body	Zinc plated steel
Hysteresis	15% setting point
Tolerance	8% setting point

## SEQUENCE VALVE POPPET TYPE in line mounting type CPR-LG38/\*

### 1 DESCRIPTION

Valve is designed as simple in line valve with relief and anti-cavitation function. When the pressure at the inlet 1 reaches the set value, the poppet starts to open to 2. If there is any load on the side 2, the valve body shifts against a soft spring opening the passage from 2 to 1.



### 2 ORDERING CODE

(1)	(2)	(3)	(4)
CPR	- LG38 /		-

(1) CPR: Anti-cavitation valve

(2) LG38: In line mounting - G3/8

(3) Pressure range (bar)  
 6,3 :20-70 bar  
 12 :71-130 bar  
 20 :131-210 bar  
 25 :211-280 bar  
 32 :281-350 bar  
 40 :351-420 bar

(4) required pressure setting (bar)

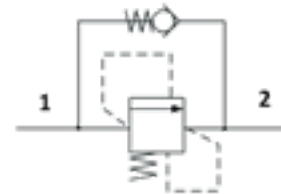

### 3 TECHNICAL DATA

Max flow	60 l/min
Maximum pressure	420 bar (42 MPa)
Max internal leakage	1,00 cc/min
Cracking pressure	0,5 bar
Weight	0,187 Kg

Back pressure on the port 2 is directly additive to the valve setting at a 1:1 ratio

### 4 TYPICAL DIAGRAMS

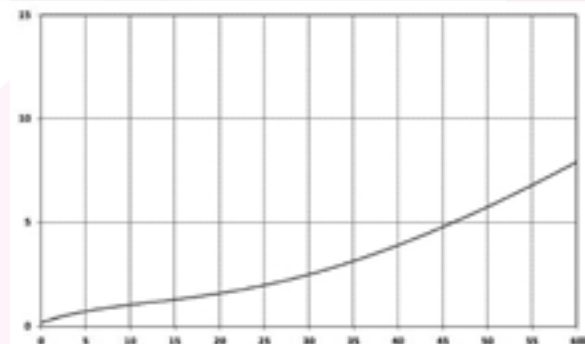
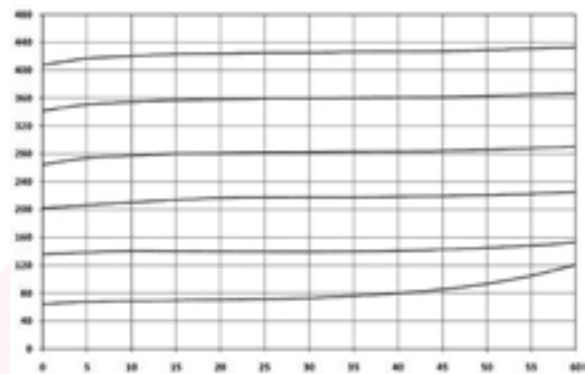

## ANTI CAVITATION VALVE POPPET TYPE METRIC CAVITY M18X1,5 CPR-M18/\*

### 1 DESCRIPTION

Valve is designed as simple insert cartridge valve with relief and anti-cavitation function. When the pressure at the inlet 1 reaches the set value, the poppet starts to open to tank 2. If there is any load on the side 2, the valve body shifts against a soft spring opening the passage from 2 to 1.



### 2 ORDERING CODE

(1)	(2)	(3)	(4)
CPR	-	LG38	/

(1) CPR: Anti-cavitation valve

(2) LG38: In line mounting - G3/8

(3) Pressure range (bar)  
 6,3 :20-70 bar  
 12 :71-130 bar  
 20 :131-210 bar  
 25 :211-280 bar  
 32 :281-350 bar  
 40 :351-420 bar

(4) required pressure setting (bar)

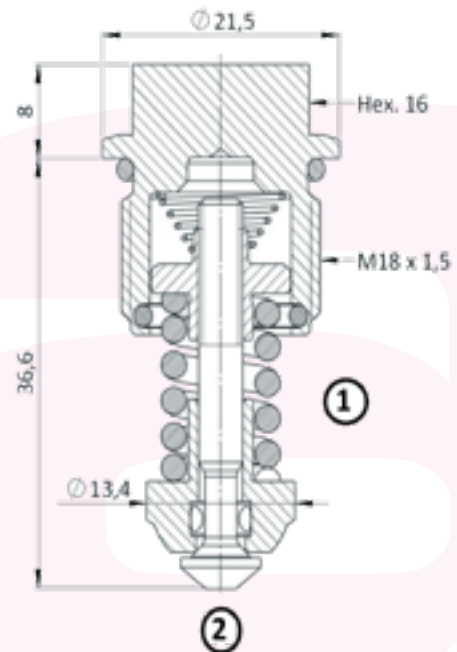
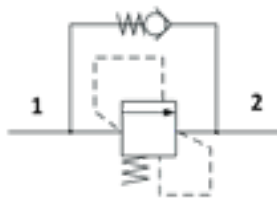
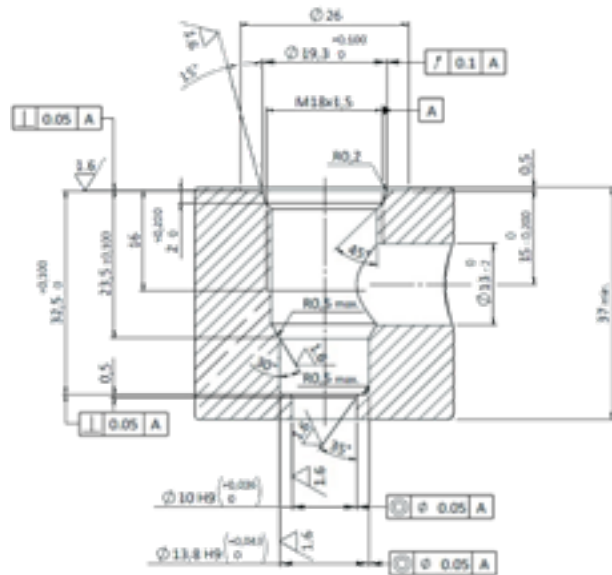

### 3 TECHNICAL DATA

Maximum flow	60 l/min
Maximum pressure	420 bar (42 Mpa)
Installation torque	35-40 Nm
Weight	0,06 Kg

Coining of the cavity is recommended for a proper installation.  
Back pressure on the port 2 is directly additive to the valve setting at a 1:1 ratio

### 4 TYPICAL DIAGRAMS

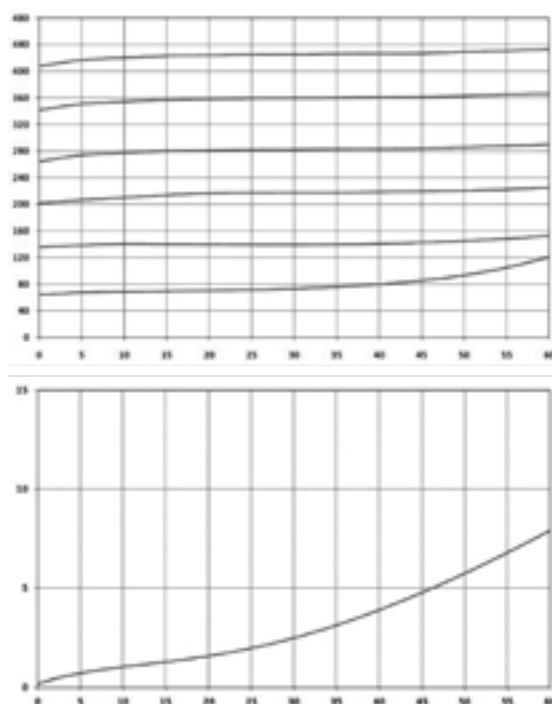

**HYBRID SAE CARTRIDGE Poppet Type  
EVMD.78.\*\*  
35 l/min - 25 MPa (250 bar)**

**1 DESCRIPTION**

Solenoid operated, 2-way 2-positions, normally closed, direct acting poppet type, bi-directional blocking, screw-in cartridge valve. Special design for low leakage in load holding applications. When the coil is de-energized, the EVMD.78.04 blocks flow in both directions. Once the coil is energized, the valve's poppet opens and allows free flow from 1 to 2 and from 2 to 1.

The rigid design using a 1-piece body contributes to minimize the effect of eccentricities in cavity and provides great reliability.

Low pressure drop thanks to optimized flow path.

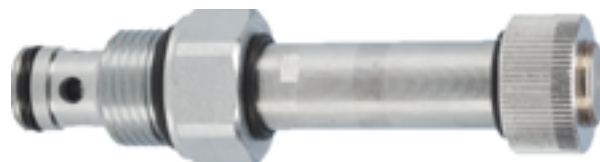

**2 ORDERING CODE**

(1)	(2)	(3)	(4)
EVMD	78	-	*

(1) EVMD : screw-in directional solenoid valve, double poppet direct operated

(2) 78: cavity 7/8" 14 UNF

(3) Valves variants

03: Without manual override

04: Manual override push pin

(4) \*: Electric voltage and solenoid coils: see **8**

0000: no coils

012C: coils for V12DC

024C: coils for V24DC

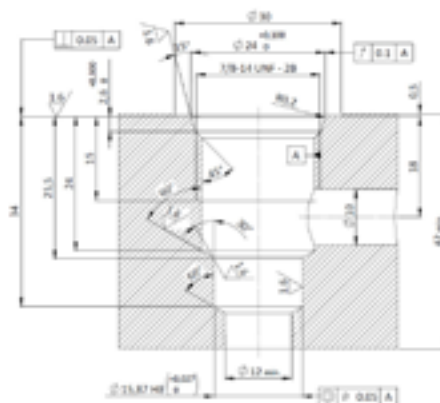

All external surfaces are zinc plated and corrosion-proof. All valve parts are made of high strength steel. Poppet is hardened and ground to ensure minimal wear and extended service life. Coil seals protect the solenoid system. Manual override option. Industry SAE common cavity.

**3 TECHNICAL DATA**

Max flow	35 l/min
Maximum pressure	250 bar (25 MPa)
Max internal leakage	max 5 drops/min 250 bar
Weight	0.225 kg

**1**

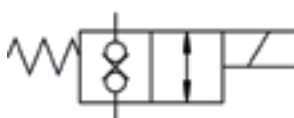

**2**

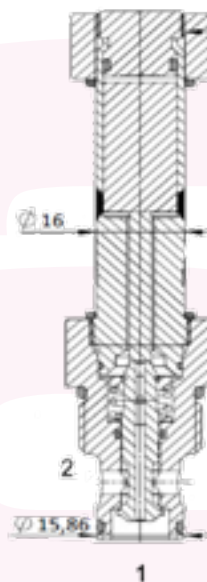



**GAS CARTRIDGE-Direct acting-Ball type**  
**CVG14**  
**35 l/min - 35 MPa (350 bar)**

**1 DESCRIPTION**

A screw-in, direct acting, ball type in-line check valve.  
 Main use is as a blocking or load-holding device.  
 The CVG14 allows flow passage from port 1 to 2: the cartridge has a fully guided check which is spring-biased closed until sufficient pressure is applied at port 1 to open to 2  
 The flow is blocked in the opposite direction (2 to 1).



**2 ORDERING CODE**

(1)	(2)		(3)
CVG	14	-	*

(1) CVG : valve basic code

(2) 14: size G14

(3)Cracking pressure:  
 -: standard 0 bar  
 1: 1 bar  
 3: 3 bar

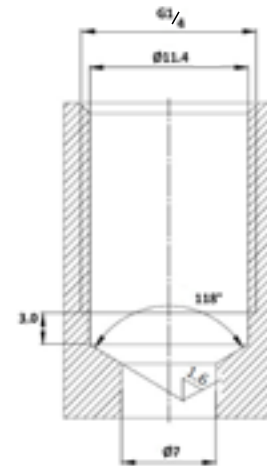

**3 TECHNICAL DATA**

Max flow	20 l/min
Maximum pressure	350 bar (35 MPa)
Max internal leakage	max 4 drops/min 250 bar
Weight	0.013 kg

External surfaces are oxide burnished and corrosion-protected.  
 All valve parts are made of high strength steel.  
 Reversed installation is possible (except for size G18) yet not recommended.  
 Compact size. Gas cavity.

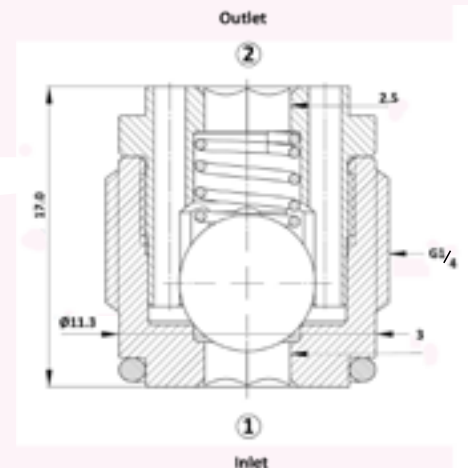

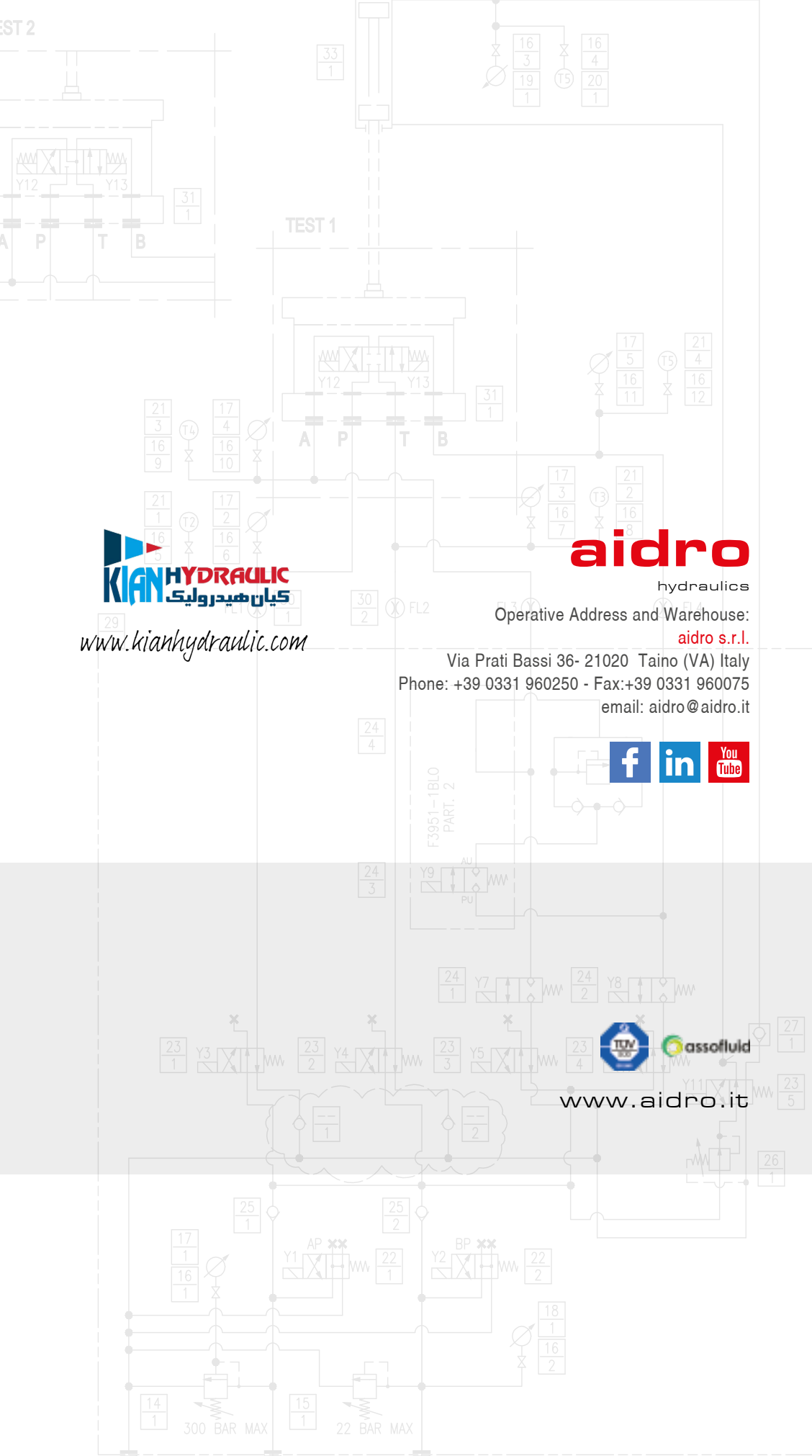

www.kianhydraulic.com

**aidro**

hydraulics

Operative Address and Warehouse:

**aidro s.r.l.**

Via Prati Bassi 36- 21020 Taino (VA) Italy

Phone: +39 0331 960250 - Fax: +39 0331 960075

email: aidro@aidro.it



www.aidro.it

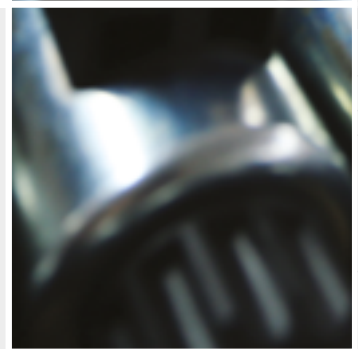

**hydraulic solutions**